

Spencer® Vortex® Regenerative Blowers



Installation, Operation and Maintenance Instructions

Serial No:

Model No:



VB037XP



VB002



VB055

Important

Read and become familiar with this manual prior to unpacking and installing your Spencer Vortex Blower. Following the instructions detailed here will help you realize its full potential of efficient service and extended lifespan. Damage resulting from failure to follow correct procedure will void the warranty.



**INDUSTRIAL EQUIPMENT • MAJOR STOCKING DISTRIBUTOR
ENGINEERING • SALES • SERVICE • PARTS**

242 POPLAR STREET • P.O. BOX 8053 • TOLEDO, OH 43605 • (419) 691-3571 • FAX (419) 691-1928
5091 WEST 164TH STREET • CLEVELAND, OHIO 44142 • (216) 265-0666 • FAX (216) 265-0667
1-800-882-1992 (OHIO TOLL FREE) 1-855-691-0621 (MICHIGAN TOLL FREE)

www.tomlinequip.com

Contents

I. General	Page
Scope	2
Limited Warranty	2
Safety Precautions	2
II. Installation	
Locating, Mounting, Connecting	2
Wiring	3
III. Operation	
Limits of Operation	4-5
Temperature Rise	5
IV. Disassembly and Reassembly	
General	5
Disassembly Procedure	5
Reassembly Cautions	5
Locknut Torque	6
V. Vortex Blower Data	
Assembly Diagrams	6-17
Parts Lists	6-17
Performance Curves	6-17
VI. Troubleshooting Guide	18

I. General

Scope

Information contained in this manual relates to Vortex Blowers standard and explosion-proof motor models VB001S, VB001, VB002S, VB002, VB003S, VB003, VB004S, VB004, VB007S, VB007, VB019S, VB019, VB030S, VB030, VB037S, VB037, VB055, VB075, and VB110.

Limited Warranty

We warrant that this product will be free from defects in material and workmanship for a period of 18 months from date of shipment or 12 months from date of startup, whichever comes first. Within the warranty period, we shall repair or replace F.O.B. our Factory such products that are determined by us to be defective.

This warranty will not apply to any product which has been subjected to misuse, negligence, or accident, or misapplied or improperly installed. This warranty will not apply to any product which has been disassembled, repaired, or otherwise altered by any persons not authorized by the Spencer Vortex Service Department.

On units which include thermal protection, the thermal protection must be connected as recommended.

The guarantee of the motor and control manufacturers will govern the extent of our guarantee on such equipment. Warranty work on motors and controls must be authorized by Spencer and must be performed in an authorized shop as designated by the manufacturers.

The Spencer Turbine Company reserves the right to invoice all expenses incurred when repairs are made in the field at the specific request of the customer.

No assemblies or parts of assemblies will be accepted for repair or replacement under this warranty without prior authorization by The Spencer Turbine Company. For complete warranty information, obtain Spencer's Form 706, "Terms and Conditions of Sales."

Safety Precautions

Power sources, protective devices, and grounding provisions must be in accordance with wiring instructions provided in this manual.

Blower becomes hot during operation and may cause burns if touched.

Do not operate the blower under load conditions which exceed the rated full-load amps on the nameplate.

Do not install the blower in any area which may have an explosive atmosphere or which may contain flammable gases or liquids. Always provide proper ventilation. Do not install in any area which may subject the blower to corrosive liquids. Excessive moisture may cause electrical failure; install the blower in areas free from water or rain. Do not operate blower without motor cooling fan cover, or without impeller end cover.

Before installing blowers with explosion-proof motors, the buyer must check federal, state and local codes to see if such motors are appropriate for the intended application environment. It is the buyer's responsibility to determine the suitability of any product for a particular purpose.

Storage

If machine is to be stored for an extended period of time, it must be carefully protected from dampness and dirt.

II. Installation

Locating, Mounting, Connecting

Ambient temperature at the installed location should not be less than -5° F or greater than 104° F. Relative humidity should not exceed 80%.

Mount the blower in a horizontal or vertical position as shown in Figure 1. For models VB055, VB075 and VB110, it is recommended to mount in the horizontal position only. Check with factory *prior* to mounting these models vertically.

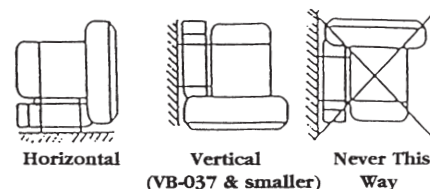

Fig. 1 Mounting Positions

Remove protective coverings, such as vinyl tape or plastic plugs, from the inlet and outlet ports. Models VB001, VB002 and VB003 are supplied with a patented (U.S. Patent 5,791,870) reversible flange with threaded pipe or tubing connections. Avoid excessive stress caused by pipe connector tightening or by misaligned pipe on the inlet and outlet ports. Support piping by brackets or other means.

In the event the blower is located where dust, fibers, drops of water, or other particulates may be in the airstream, use a filter on the suction side of the piping. If foreign matter enters the impeller, it may clog, jam, or otherwise impair the blower performance.

Wiring

Caution: Confirm that the power source is the same as that indicated on the unit's nameplate. Application of incorrect voltage or improper phase connection may cause motor failure or other damage.

Use conductors and devices that are suitable for the applications shown in Tables 1 and 2 and are in compliance with the National Electric Code and applicable local codes and regulations. Motor terminal connections are shown below.

Provide protection from overheating of the motor windings. Some models are equipped with built-in thermal protectors (see Table 1 on page 4). Where applicable, connect the leads from the pilot-duty thermal protector to the magnetic starter.

Check the direction of rotation of the blower.

To reverse the direction or rotation:

- 1) for a single-phase motor, interchange motor leads 5 and 8.
- 2) for a three-phase motor, interchange any two of the three line connections.

Caution: Install a properly-sized overload device and disconnect in accordance with local codes and regulations and dedicated only to the Vortex Blower.

Furnish the Vortex Blower and all associated electrical devices with a proper ground in accordance with all local codes and regulations.

MOTOR WIRING CW Rotation

Three-Phase

DUAL VOLTAGE Y-CONNECTED

Voltage	L1	L2	L3	Join
Low	1,7	2,8	3,9	4&5&6
High	1	2	3	4&7,5&8,6&9

DUAL VOLTAGE DELTA-CONNECTED

Voltage	L1	L2	L3	Join
Low	1,6,7	2,4,8	3,5,9	—
High	1	2	3	4&7,5&8,6&9

Single-Phase

Low Voltage

Line

High Voltage

Line

VB037 230V Single-Phase Single Voltage

Line

575V Three-Phase Single Voltage

Line

THERMOSTAT RATINGS
VB004 and Larger

Volts	Amps
115	6.0
230	3.0
460	1.5
575	1.2

Thermostat Leads

NOTES: (1) For three-phase, interchange any two line connections to reverse shaft rotation.
 (2) For single-phase, interchange motor leads 5 and 8 to reverse shaft rotation.

Table 1 Three-Phase Motor Data - Typical Values

60 Hertz Operation						
Model No.	VB001	VB002	VB003	VB004	VB007	VB019
Power (hp)	0.13	0.25	0.5	0.75	1.5	2.5
Voltage (V)	200-230/460	200-230/460	208-230/460	200-230/460	200-230/460	200-230/460
FL Amp (A)	.5-.48/.24	.86-.73/.37	1.8-1.6/.8	2.3-2.4/1.2	4.3-4/2	7.2-6.6/3.3
Voltage (V)		575	575	575	575	575
FL Amp (A)		.4	0.8	0.96	1.4	2.1
Model No.	VB030	VB037	VB055	VB075	VB110	—
Power (hp)	4	5	7.5	10	15	—
Voltage (V)	200-230/460	200-230/460	200-230/460	200-230/460	200-230/460	—
FL Amp (A)	10.6-10.2/5.1	13.2-12/6	19.8-17.2/8.6	27.5-27.2/13.6	39-37/18.5	—
Voltage (V)	575	575	575	575	575	—
FL Amp (A)	3	4.8	7	9.6	13.5	—
50 Hertz Operation						
Model No.	VB001	VB002	VB003	VB004	VB007	VB019
Power (hp)	0.13	0.21	0.5	0.63	1.25	2.1
Voltage (V)	190-220/380-415	190-220/380-415	190/380-415	190/380-415	190/380-415	190/380-415
FL Amp (A)	.5-.52/.25-.26	.74-.66/.37-.34	2/1-.9	2.4/1.2-1.3	4/2	6.6/3.3-3.1
Model No.	VB030	VB037	VB055	VB075	VB110	—
Power (hp)	3.4	4.2	6.25	8.33	12.5	—
Voltage (V)	190/380-415	190/380-415	190/380-415	190/380-415	190/380-415	—
FL Amp (A)	10.2/5.2-5.1	11.8/5.9-5.6	17.6/8.8-8.2	27/13.5-14.5	36/18-17	—

NOTE: Thermostats are provided on the VB004 and larger models.

Table 2 Single-Phase Motor Data - Typical Values

60 Hertz Operation								
Model No.	VB001S	VB002S	VB003S	VB004S	VB007S	VB019S	VB030S	VB037S
Power (hp)	0.13	0.25	0.5	0.75	1.5	2.5	4	5
Voltage (V)	115/230	115/230	115/230	115/208-230	115/208-230	115/208-230	115/208-230	230
FL Amps (A)	1.25/.63	2.3/1.15	5.2/2.6	9.6/5-4.8	13.4/6.7	22/11.5-11	34.8/18.5-17.4	20.8
50 Hertz Operation								
Model No.	VB001S	VB002S	VB003S	VB004S	VB007S	VB019S	VB030S	VB037S
Power (hp)	0.13	0.21	0.5	0.63	1.25	2.1	3.3	4.2
Voltage (V)	110/220	110/220	110/220	100-110/220	110/220	100-110/220	100-110/220	220
FL Amps (A)	1.34/.67	2.1/1.05	5.6/2.8	9.9-11.6/5.8	15.4/7.7	22-21/10.5	42-38.6/19.3	19

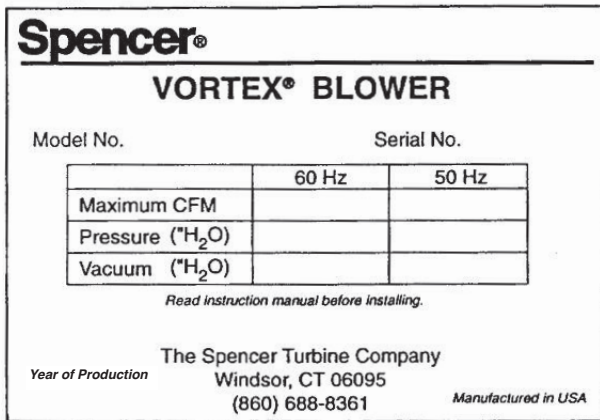

Fig. 4 Typical Nameplate

III. Operation

Limits of Operation

Operation at flows less than those indicated by the solid line on the applicable performance curve will cause overheating of the unit and is to be avoided. **Throttling suction or discharge piping to reduce air volume increases differential pressure resulting in elevated temperature and increased power consumption. Use of pressure and/ or vacuum relief valve recommended.**

Maximum pressure and vacuum are indicated on the nameplate (see Fig. 4). These represent conditions at which the minimum allowable airflow (CFM) occurs. Check the operating pressure or vacuum to assure that the pressure or vacuum remains less than maximum.

For continuous operation at low air volume (on the dotted portion of the performance curve), provide a bypass in the piping and operate at a lower pressure than maximum operating pressure. See Performance Curves, Section V.

Caution: Low flow conditions may produce heat levels which may cause burns. Do not touch the blower in operation.

Temperature Rise

A NEMA Class F insulation system is used in the motor. Maximum allowable winding temperature is 265°F. If a thermal protector or thermal relay activates because the temperature rise of the motor is higher than usual, investigate and correct the problem. Explosion-proof motors use a NEMA Class B insulation. Typical causes of motor overheating are given in Section VI, Troubleshooting Guide.

IV. Disassembly and Reassembly

A. General

1. Precautions should be taken when disassembling or reassembling the blower. See Warranty Terms.
2. Keep all parts clean.
3. Do not overtighten bolts and screws.

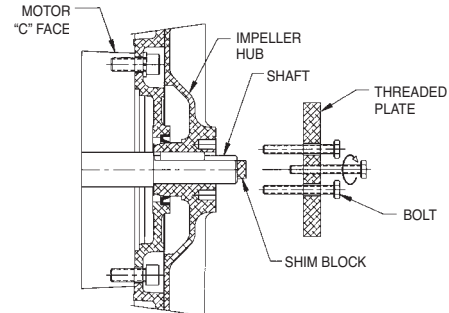

Fig. 5 Impeller Puller

B. Disassembly Procedure (Reassembly is performed in reverse order)

Caution: Shims are used to adjust the gap between the impeller and casing. When disassembling, take care to note the quantity of shims and their thickness. The shim stack replacement must be the correct thickness to assure proper clearance and to avoid degradation of performance.

1. Remove impeller cover; remove screws, pull cover away from case.
2. Unfasten lock washer; remove nut and washer.
3. Remove impeller from shaft by one of the following methods:
 - a. manually pull the impeller outward, OR
 - b. screw two bolts into tapped holes and pull on the bolts, OR (if the fit is tight)
 - c. use a puller assembly (not furnished) as shown in Fig. 5.
4. Remove motor shaft key.
5. Remove case from motor; if necessary remove screws holding case to base and motor to case.
6. Remove shims from motor shaft if necessary; do not discard them. See Note above.

Caution: Motors are heavy. Lift motor on models larger than VB002 by the eyebolt on the motor with an aid from a lifting device.

C. Reassembly Guidance

1. The gap between the impeller and case is essential for proper performance of the unit. The shims between the shaft collar and impeller hub establish the spacing of this gap. In reassembly, before installing the impeller cover, check the gap between the impeller and case to assure that the measurement conforms to the gap specification on the assembly drawing (on the following pages) for your unit.

2. For models VB001, VB002 and VB003, gap clearance between impeller and unibody case should be checked around entire periphery of the impeller in accordance with Item 18, impeller to case gap specification prior to securing impeller.
3. On models VB004 thru VB110 remove Item 23 Plug located on bottom of the case and check impeller gap with a feeler gauge. Remove impeller and adjust shims to meet gap specification. With adjustments and gap check complete, replace plug tightly to prevent air leakage.
4. Fasten impellers using lockwashers and locknuts. Torque locknut to recommended torque values in Table 3. Bend a lockwasher tab down into a lockwasher slot.
5. Reattach the impeller cover.

Catalog No.	Recommended Torque (Ft-Lb)
VB001, VB001S, VB002 VB002S, VB003, VB003S	22
VB004, VB004S	31
VB007, VB007S	36
VB019, VB019S	36
VB030, VB030S	44
VB037, VB037S	44
VB055	77
VB075	90
VB110	90

Table 3 Locknut Torque

V. Vortex Blower Data

Pages 7 through 17 present information about the various blower models. This information is important in understanding your blower's performance, in using the blower in the proper operating range, and in ordering parts that might be needed.

A. Assembly Diagrams

At the top of each page is an assembly diagram of the unit. Items are identified by circled numbers around the diagram. Above each diagram is the gap specification.

B. Parts Lists

At the lower left of each diagram is a table giving the item number (shown on the Assembly Diagram), the Part No. for that item and the corresponding part description. In ordering parts, provide the model number, the part number and the description.

C. Performance Curves

At the lower right of each diagram are performance curves for 50Hz and 60Hz operation. The curves present the following information:

The upper line of each curve is pressure performance while the lower line is vacuum performance. The dashed portion at the left end of some of the curves indicates an intermittent-only operating area. See **Operation** Section on page 5.

D. Estimated Acoustical Noise Level at 1.5M, 60Hz

Model	dba
VB001S	62
VB001	61
VB002S	61
VB002	61
VB003S	66
VB003	66
VB004S	63
VB004	63
VB007S	70
VB007	64
VB019S	70
VB019	73
VB030S	71
VB030	73
VB037S	74
VB037	76
VB055	82
VB075	81
VB110	80

Spencer® Vortex® Regenerative Blowers

VB001S, VB001

Assembly Diagram

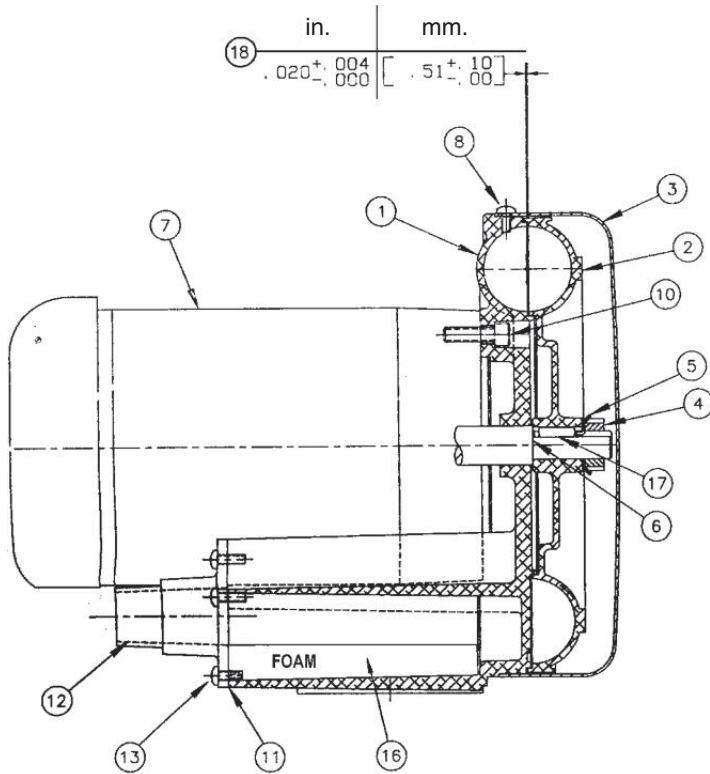

Parts List

DESCRIPTION: VORTEX BLOWER ASSEMBLY – VB001S & VB001			
ITEM	PART NO.	DESCRIPTION	QTY.
1	VBC90101	Case, Unibody	1
2	VBI90101	Impeller	1
3	VBE90101	Cover, Impeller	1
4	NUT90219	Locknut, Shaft	1
5	WSH90184	Lockwasher, Shaft	1
6	WSH90185	Shim, Shaft to Impeller (as required)	1
7	MOT90210	Motor 42C, 1/8 HP, 1PH, 50/60Hz	1
7A	MOT90215	Motor 42C, 1/8 HP, 3PH, 50/60Hz	1
8	SCR90901	M4 x 0.7 Pan Head Phillips Screw x .31 [8] Long	4
10	SCR90307	1/4-20 x .625" Long Socket Cap Screw	4
11	GSK90168	Gasket, Flange	1
12	FLC90013	Flange	1
13	SCR90888	M5 x 0.8 Hex Head Bolt x .63 [16] long	6
16	INS90014	Absorber	2
17	KEY90083	Key	1
18	N/A	Impeller to case gap specification	N/A

VB001S, VB001

Performance Curves

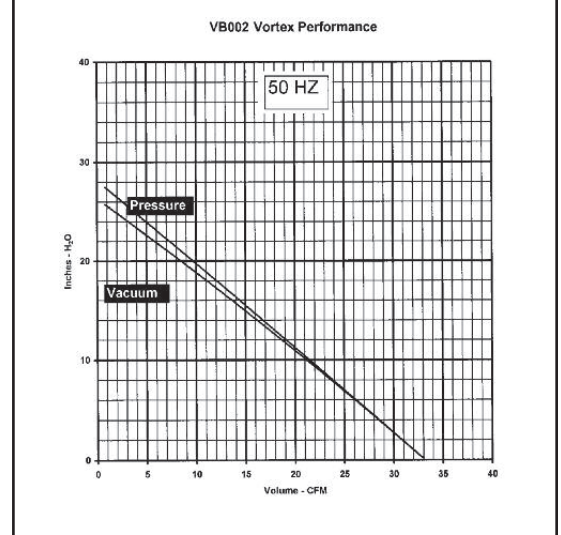
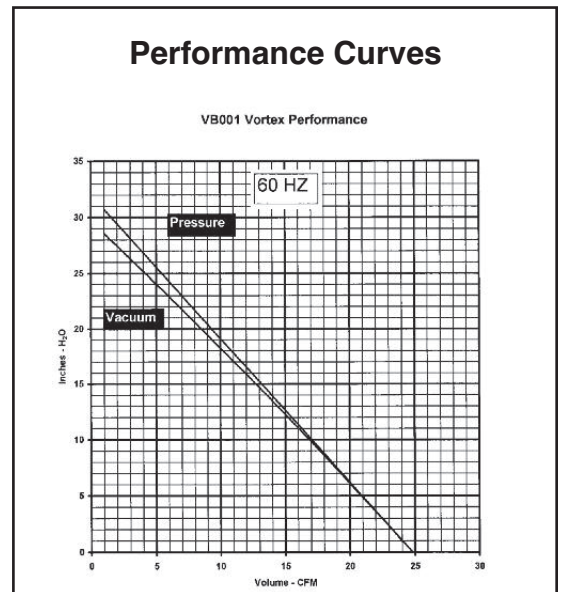

Spencer® Vortex® Regenerative Blowers

VB002S, VB002

Assembly Diagram

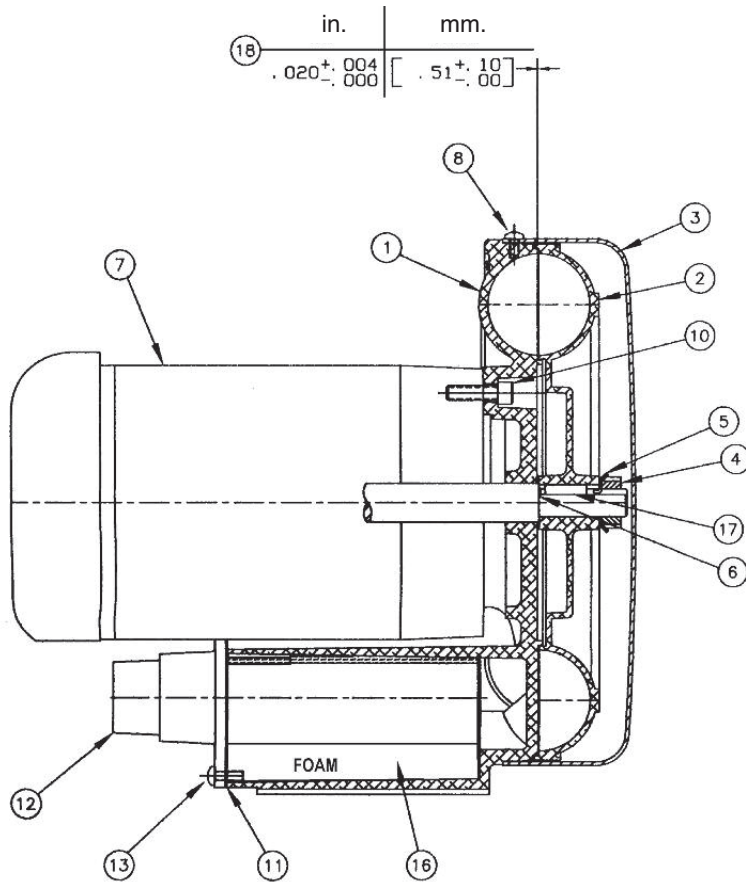

Parts List

DESCRIPTION: VORTEX BLOWER ASSEMBLY – VB002S & VB002			
ITEM	PART NO.	DESCRIPTION	QTY.
1	VBC90201	Case, Unibody	1
2	VBI90201	Impeller	1
3	VBE90201	Cover, Impeller	1
4	NUT90219	Locknut, Shaft	1
5	WSH90184	Lockwasher, Shaft	1
6	WSH90185	Shim, Shaft to Impeller (as required)	1
7	MOT90211	Motor 42C, 1/4 HP, 1PH, 50/60Hz	1
7A	MOT90212	Motor 42C, 1/4 HP, 3PH, 50/60Hz	1
8	SCR90901	M4 x 0.7 Pan Head Phillips Screw x .31 [8] Long	4
10	SCR90307	1/4-20 x .625" Long Socket Cap Screws	4
11	GSK90169	Gasket, Flange	1
12	FLC90014	Flange	1
13	SCR90888	M5 x 0.8 Hex Head Bolt x .63 [16] Long	6
16	INS90015	Absorber	2
17	KEY90085	Key	1
18	N/A	Impeller to case gap specification	N/A

VB002S, VB002

Performance Curves

VB002 Vortex Performance

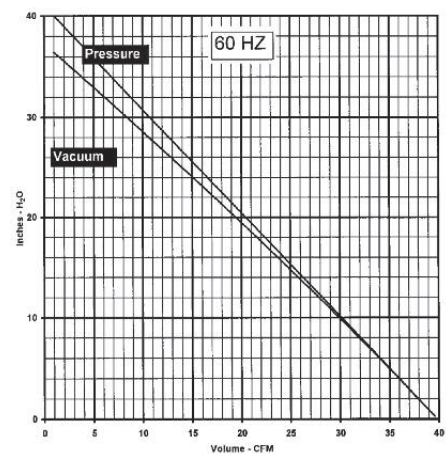

VB002 Vortex Performance

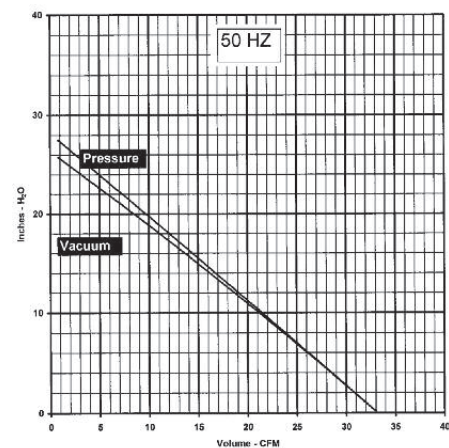

Spencer® Vortex® Regenerative Blowers

VB003S, VB003

Assembly Diagram

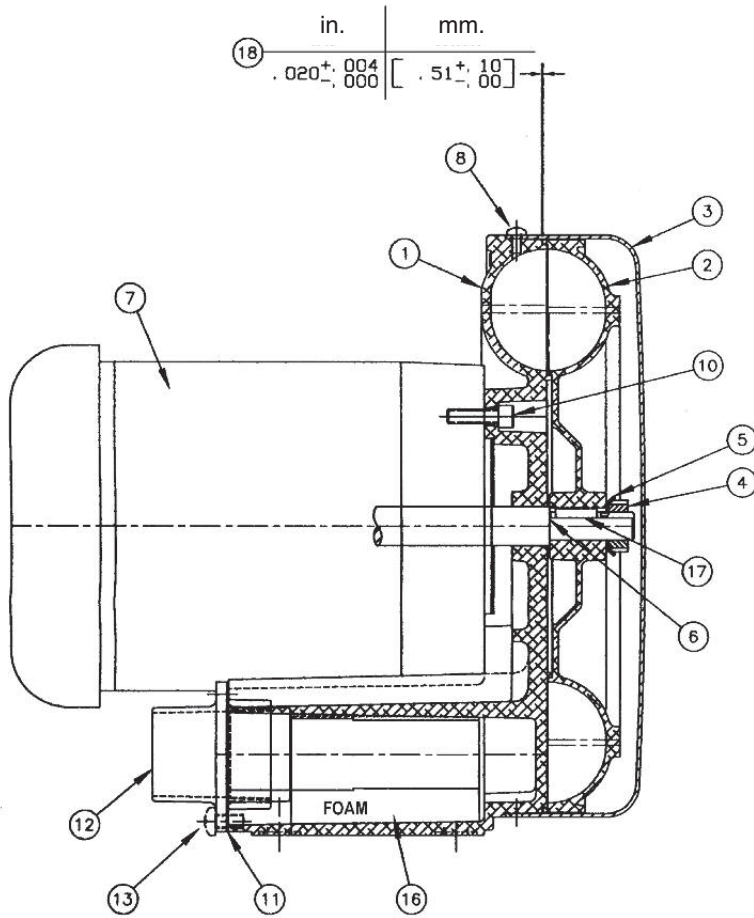

Parts List

DESCRIPTION: VORTEX BLOWER ASSEMBLY – VB003S & VB003			
ITEM	PART NO.	DESCRIPTION	QTY.
1	VBC90301	Case, Unibody	1
2	VBI90301	Impeller	1
3	VBE90301	Cover, Impeller	1
4	NUT90219	Locknut, Shaft	1
5	WSH90184	Lockwasher, Shaft	1
6	WSH90185	Shim, Shaft to Impeller (as required)	1
7	MOT90213	Motor 48C, 1/2 HP, 1PH, 50/60Hz	1
7A	MOT90214	Motor 48C, 1/2 HP, 3PH, 50/60Hz	1
7B	MOT90229	Motor 48C, 1/2 HP, 3PH, 575 Volt, 50/60Hz	1
7C	MOT90470	Motor 48C, 1/2 HP, 3PH, 60Hz	1
7D	MOT90469	Motor 48C, 1/2 HP, 1PH, 60Hz	1
8	SCR90901	M4 x 0.7 Pan Head Phillips Screw x .31 [8] Long	4
10	SCR90307	1/4-20 x .625" Long Socket Cap Screw	4
11	GSK90170	Gasket, Flange	1
12	FLC90015	Flange	1
13	SCR90888	M5 x 0.8 Hex Head Bolt x .63 [16] Long	6
16	INS90016	Absorber	2
17	KEY90085	Key	1
18	N/A	Impeller to case gap specification	N/A

VB003S, VB003

Performance Curves

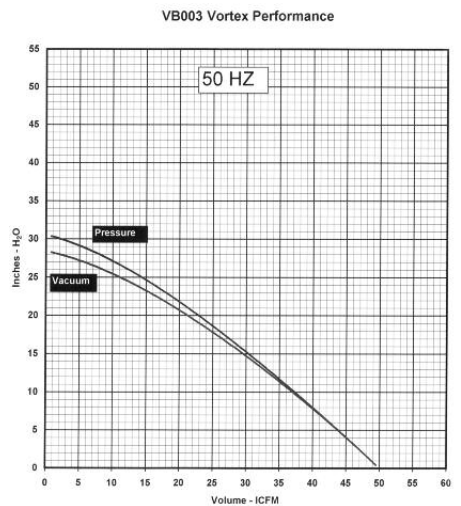
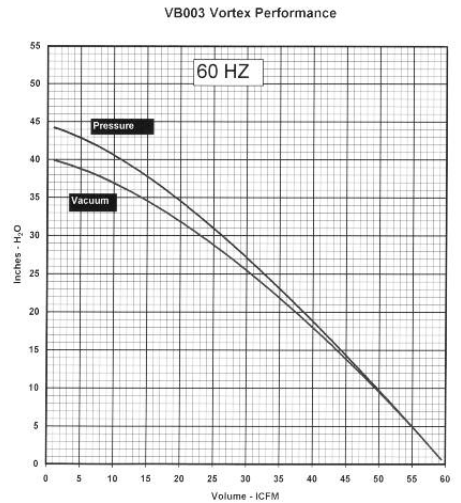

Spencer® Vortex® Regenerative Blowers

VB004S, VB004

Assembly Diagram

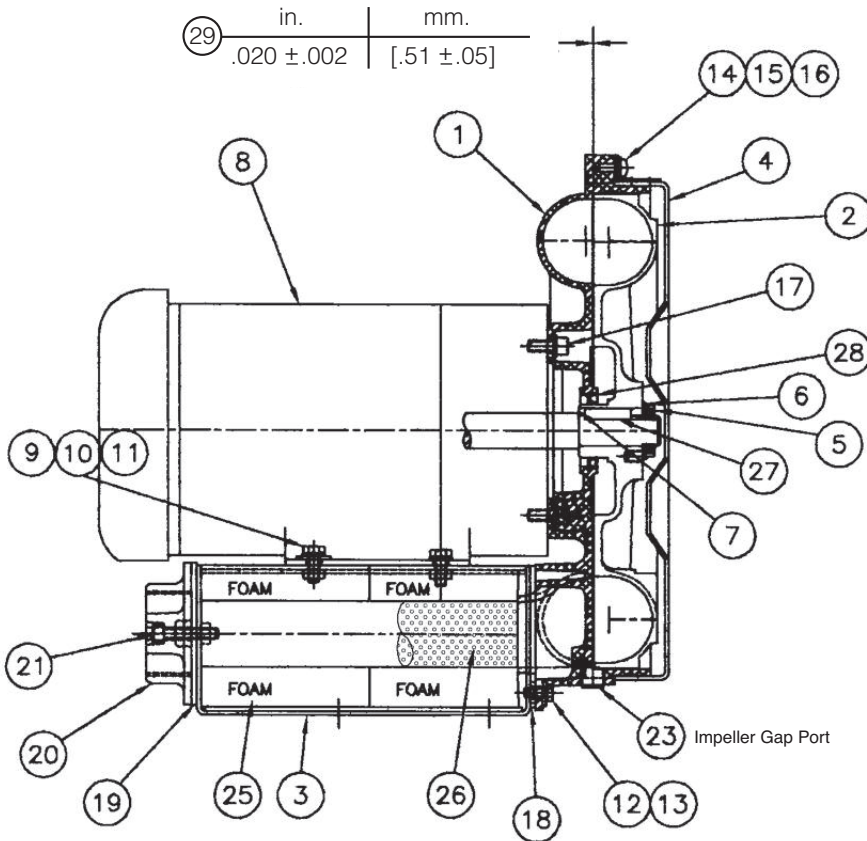

Parts List

DESCRIPTION: VORTEX BLOWER ASSEMBLY – VB004S & VB004			
ITEM	PART NO.	DESCRIPTION	QTY.
1	VBC90401	Case	1
2	VBI90401	Impeller	1
3	VBB90401	Base	1
4	VBE90401	Cover, Impeller	1
5	NUT90212	Locknut, Shaft	1
6	WSH90170	Lockwasher, Shaft	1
7	WSH90177	Shim, Shaft to Impeller (as required)	1
8	MOT90193	Motor 48C, 3/4 HP, 1PH, 50/60Hz	1
8A	MOT90192	Motor 48C, 3/4 HP, 3PH, 50/60Hz	1
8B	MOT90230	Motor 48C, 3/4 HP, 3PH, 575 Volt, 50/60Hz	1
8C	MOT90471	Motor 48C, 3/4 HP, 3PH, 60Hz	1
8D	MOT90472	Motor 48C, 3/4 HP, 1PH, 60Hz	1
9	SCR90887	M6 x 1.0 Hex Head Bolt x .63 [16] Long	4
10	WSH90142	Lock washer, M5	4
11	WSH90166	Flat Washer, M5	4
12	SCR90888	M5 x 0.8 Hex Head Bolt x .63 [16] Long	2
13	WSH90181	Flat Washer, M5	2
14	SCR90877	M5 x 0.8 Pan Head Phillips Screw x .39 [10] Long	4
15	WSH90138	Lockwasher, M5	4
16	WSH90139	Flat Washer, M5	4
17	SCR90307	1/4-20 x .625" Long Socket Cap screw	4
18	GSK90165	Gasket, Case	1
19	GSK90163	Gasket, Flange	2
20	FLC90007	Flange	2
21	SCR90931	M6 x 1.0 S.H.C.S. x .98 [25] Long	4
23	PLG90037	Plug, 1/4 NPT x .43 [11] Long	1
25	INS90017	Absorber	4
26	SCN90065	Screen	2
27	KEY90076	Key	1
28	SEL90108	Lip Seal	1
29	N/A	Impeller to case gap specification	N/A

VB004S, VB004

Performance Curves

VB004 Vortex Performance

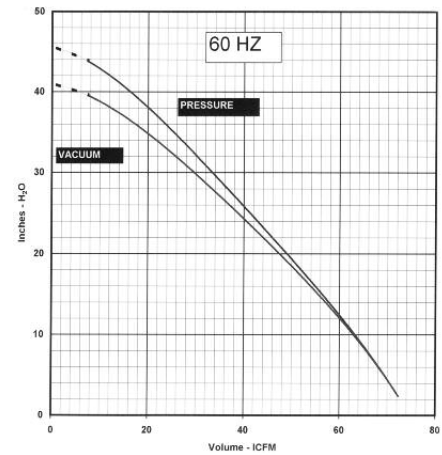

VB004 Vortex Performance

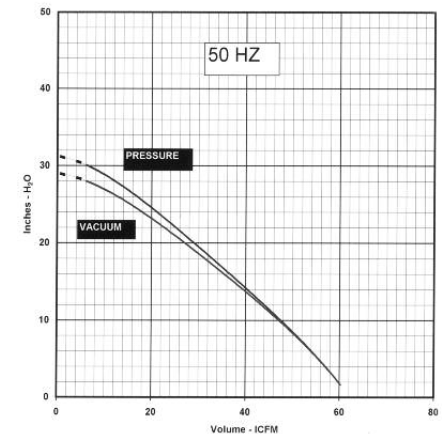

Spencer® Vortex® Regenerative Blowers

VB007S, VB007, VB007SXP, VB007XP

Assembly Diagram

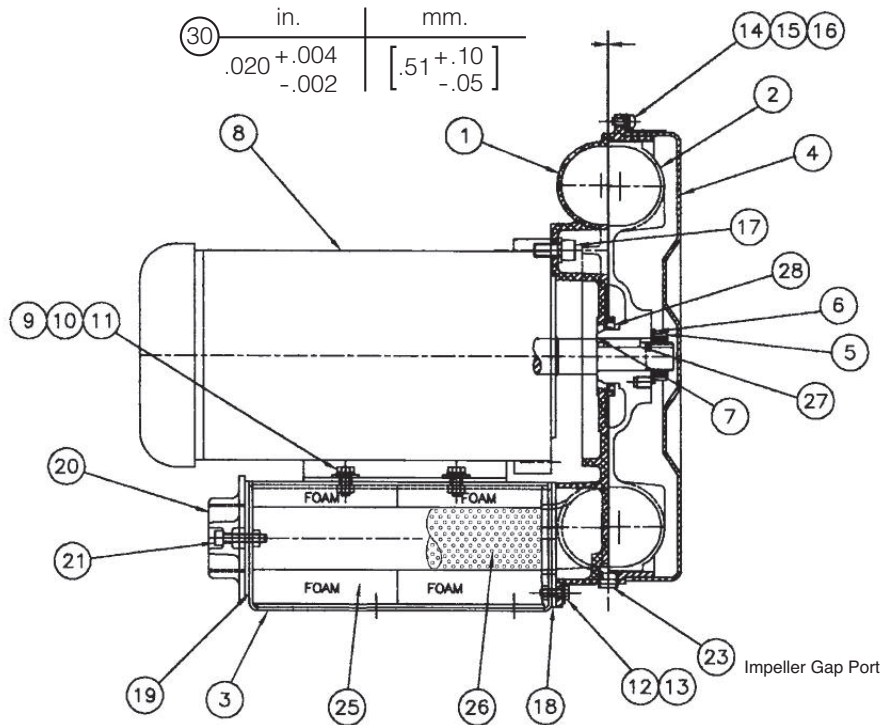

(See Bulletin 417, pages 34 and 35 for specifics on models with explosion-proof motors.)

Parts List

DESCRIPTION: VORTEX BLOWER ASSEMBLY – VB007S, VB007, VB007SXP, VB007XP			
ITEM	PART NO.	DESCRIPTION	QTY.
1	VBC90701	Case	1
2	VBI90701	Impeller	1
3	VBB90701	Base	1
4	VBE90701	Cover, Impeller	1
5	NUT90210	Locknut, Shaft	1
6	WSH90171	Lockwasher, Shaft	1
7	WSH90160	Shim, Shaft to Impeller (as required)	1
8C	MOT90225	Motor, 56C, 1-1/2 HP, 3PH, XP, 50/60Hz	1
8D	MOT90358	Motor, 56C, 1-1/2 HP, 1PH, XP, 50/60Hz	1
8G	MOT90248	Motor, 56C, 1-1/2 HP, 3PH, 50/60Hz	1
8H	MOT90253	Motor, 56C, 1-1/2 HP, 1PH, 50/60Hz	1
8I	MOT90485	Motor, 56C, 1-1/2 HP, 3PH, 60Hz	1
8J	MOT90484	Motor, 56C, 1-1/2 HP, 1PH, 60Hz	1
9	SCR90887	M6 x 1.0 Hex Head Bolt x .63 [16] Long	4
10	WSH90142	Lockwasher, M6	4
11	WSH90166	Flat Washer, M6	4
12	SCR90888	M5 x 0.8 Hex Head Bolt x .63 [16] Long	2
13	WSH90181	Washer, Flat M5	2
14	SCR90877	M5 x 0.8 Pan Head Phillips Screw x .39 [10] Long	4
15	WSH90138	Lockwasher, M5	4
16	WSH90139	Flat Washer, M5	4
17	SCR90867	3/8-16 x .75" Long Socket Cap Screw	4
18	GSK90164	Gasket, Case	1
19	GSK90163	Gasket, Flange	2
20	FLC90008	Flange, 1 1/2 FNPT	2
21	SCR90931	M6 x 1.0 S.H.C.S. x .98 [25] Long	4
23	PLG90037	Plug, 1/4 NPT x .43 [11] Long	1
25	INS90018	Absorber	4
26	SCN90064	Screen	2
27	KEY90076	Key	1
28	SEL90107	Lip Seal	1
30	N/A	Impeller to case gap specification	N/A

VB007S, VB007

Performance Curves

VB007 Vortex Performance

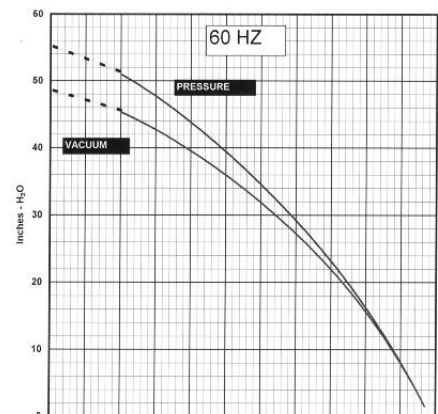

VB007 Vortex Performance

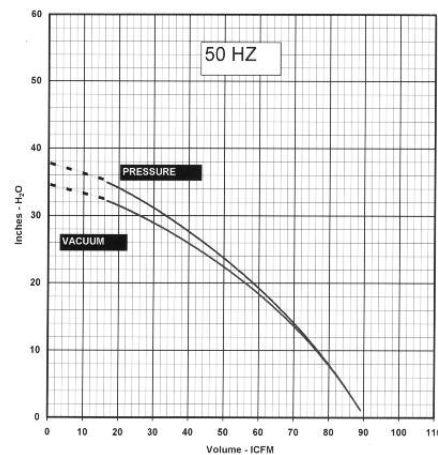

Spencer® Vortex® Regenerative Blowers

VB019S, VB019, VB019SXP, VB019XP

Assembly Diagram

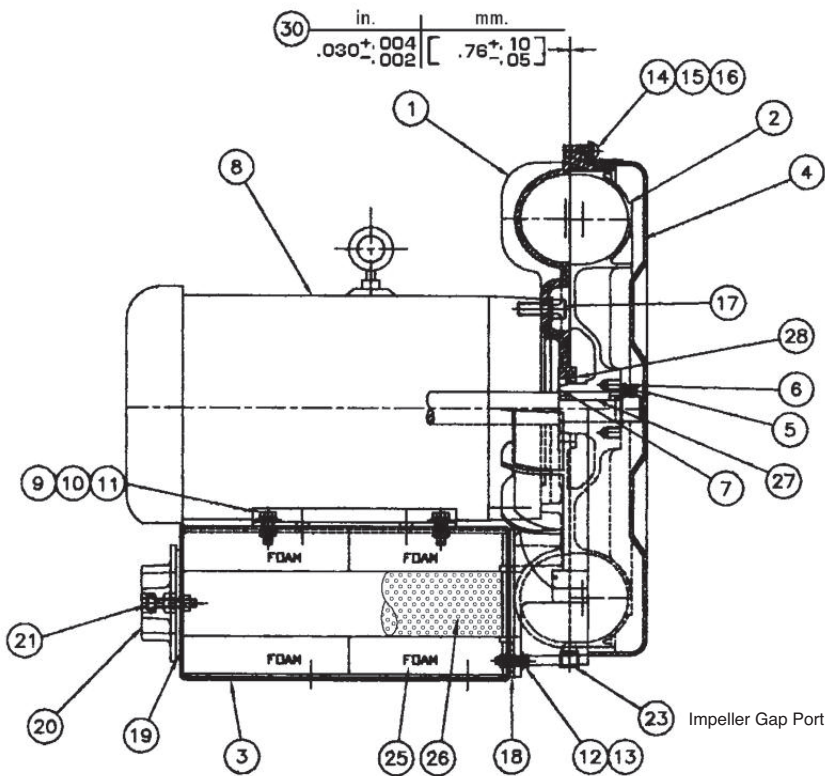

(See Bulletin 417, pages 36 and 37 for specifics on models with explosion-proof motors.)

Parts List

DESCRIPTION: VORTEX BLOWER ASSEMBLY – VB019S, VB019, VB019SXP, VB019XP			
ITEM	PART NO.	DESCRIPTION	QTY.
1	VBC91901	Case	1
2	VBI91901	Impeller	1
3	VBB91901	Base	1
4	VBE91901	Cover, Impeller	1
5	NUT90210	Locknut, Shaft	1
6	WSH90171	Lockwasher, Shaft	1
7	WSH90160	Shim, Shaft to Impeller (as required)	1
8	MOT90254	Motor, 145TC, 2-1/2 HP, 1PH, 50/60Hz	1
8A	MOT90249	Motor, 145TC, 2-1/2 HP, 3PH, 50/60Hz	1
8B	MOT90347	Motor, 145TC, 2-1/2 HP, 3PH, 575 Volt, 50/60Hz	1
8C	MOT90224	Motor, 145TC, 2-1/2 HP, 3PH, XP, 50/60Hz	1
8D	MOT90359	Motor, 145TC, 2-1/2 HP, 1PH, XP, 50/60Hz	1
8E	MOT90476	Motor, 145TC, 2-1/2 HP, 3PH, 60Hz	1
8F	MOT90475	Motor, 145TC, 2-1/2 HP, 1PH, 60Hz	1
9	SCR90887	M6 x 1.0 Hex Head Bolt x .63 [16] Long	4
9ALT	SCR90876	M6. x 1.0 Hex Head Bolt x .98 [25] Long (Cast Motor)	4
10	WSH90142	Lockwasher, M6	4
11	WSH90166	Flat Washer, M6	4
12	SCR90943	M5 x 0.8 Hex Head Bolt x .79 [20] Long	2
13	WSH90181	Flat Washer, M5	2
14	SCR90877	M5 x 0.8 Pan Head Phillips Screw x .39 [10] Long	4
15	WSH90138	Lockwasher, M5	4
16	WSH90139	Flat Washer, M5	4
17	SCR90867	3/8-16 x .75" Long Socket Cap Screw	4
18	GSK90162	Gasket, Case	1
19	GSK90163	Gasket, Flange	2
20	FLC90008	Flange, 1 1/2 FNPT	2
21	SCR90931	M6 x 1.0 S.H.C.S. x .98 [25] Long	4
23	PLG90037	Plug, 1/4 NPT x .43 [11] Long	1
25	INS90019	Absorber	4
26	SCN90063	Screen	2
27	KEY90077	Key	1
28	SEL90107	Lip Seal	1
30	N/A	Impeller to case gap specification	N/A

VB019S, VB019

Performance Curves

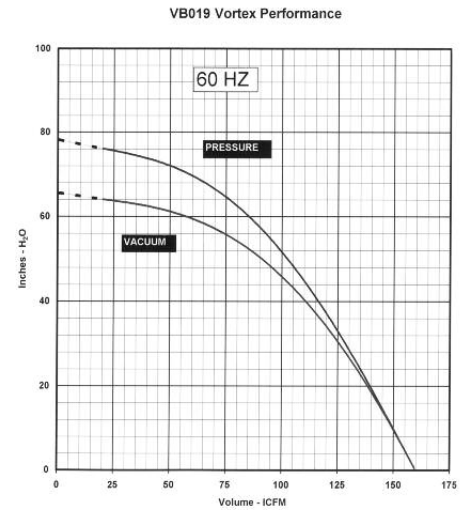

VB019 Vortex Performance

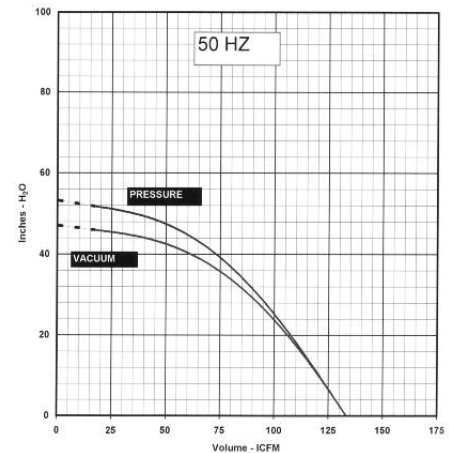

Spencer® Vortex® Regenerative Blowers

VB030S, VB030, VB030XP

Assembly Diagram

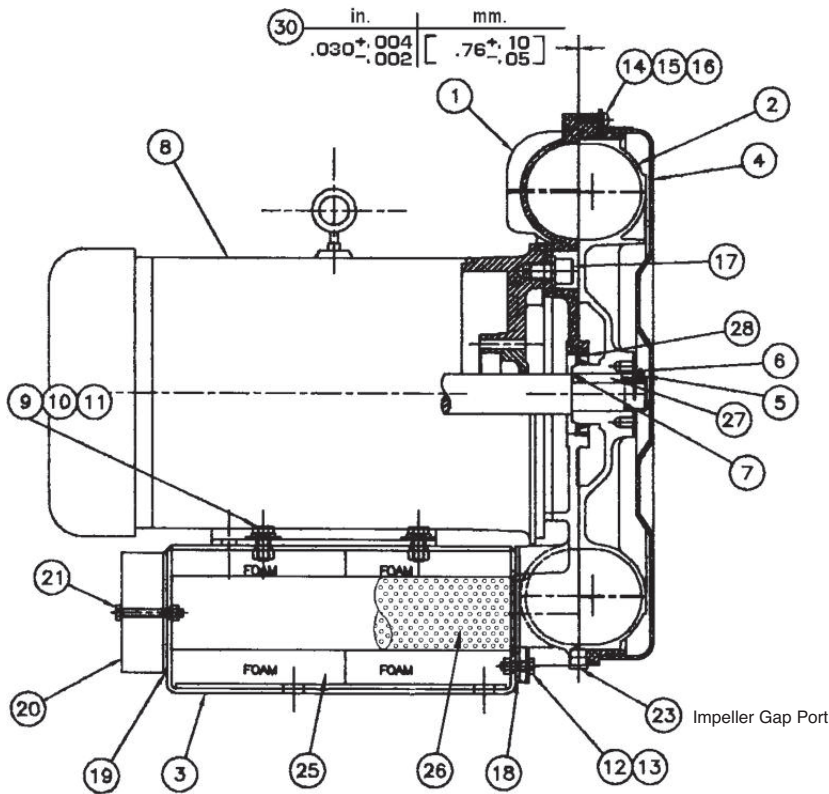

Parts List

DESCRIPTION: VORTEX BLOWER ASSEMBLY – VB030S, VB030, VB030XP			
ITEM	PART NO.	DESCRIPTION	QTY.
1	VBC93001	Case	1
2	VBI93001	Impeller	1
3	VBB93001	Base	1
4	VBE93001	Cover, Impeller	1
5	NUT90209	Locknut, Shaft	1
6	WSH90172	Lockwasher, Shaft	1
7	WSH90157	Shim, Shaft to Impeller (as required)	1
8	MOT90370	Motor, 184TC, 4 HP, 1PH, 50/60Hz	1
8A	MOT90250	Motor, 182TC, 4 HP, 3PH, 50/60Hz	1
8B	MOT90348	Motor, 182TC, 4 HP, 3PH, 575 Volt, 50/60Hz	1
8C	MOT90223	Motor, 182TC, 4 HP, 3PH, XP, 50/60Hz	1
8D	MOT90478	Motor, 182TC, 4 HP, 3PH, 60Hz	1
8E	MOT90477	Motor, 182TC, 4 HP, 1PH, 60Hz	1
9	SCR90879	M8 x 1.25 Hex Head Bolt x .98 [25] Long	4
10	WSH90148	Lockwasher, M8	4
11	WSH90182	Flat Washer, M8	4
12	SCR90876	M6 x 1.0 Hex Head Bolt x .98 [25] Long	2
13	WSH90166	Flat Washer, M6	2
14	SCR90877	M5 x 0.8 Pan Head Phillips Screw x .39 [10] Long	4
15	WSH90138	Lockwasher, M5	4
16	WSH90139	Flat Washer, M5	4
17	SCR90335	1/2 -13 x 1.0 Long Socket Cap Screw	4
18	GSK90161	Gasket, Case	1
19	GSK90155	Gasket, Flange	2
20	FLC90009	Flange, 2 FNPT	2
21	SCR90878	M6 x 1.0 Hex Head Bolt x 1.57 [40] Long	4
23	PLG90037	Plug, 1/4 NPT x .43 [11] Long	1
25	INS90020	Absorber	4
26	SCN90062	Screen	2
27	KEY90078	Key	1
28	SEL90104	Lip Seal	1
30	N/A	Impeller to case gap specification	N/A

(See Bulletin 417, pages 38 and 39 for specifics on models with explosion-proof motors.)

VB030S, VB030

Performance Curves

VB030 Vortex Performance

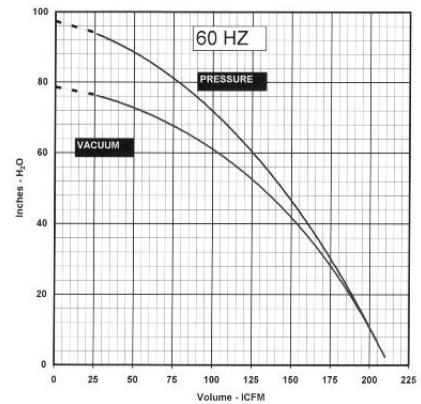

VB030 Vortex Performance

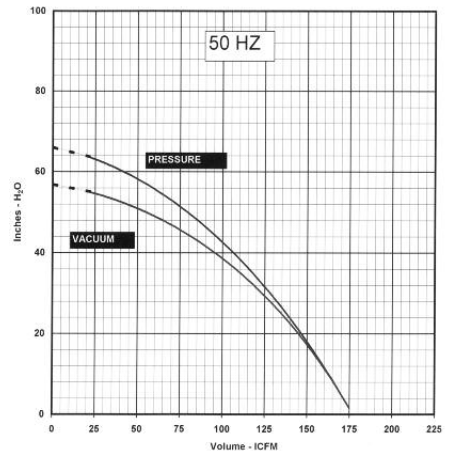

Spencer® Vortex® Regenerative Blowers

VB037S, VB037, VB037XP

Assembly Diagram

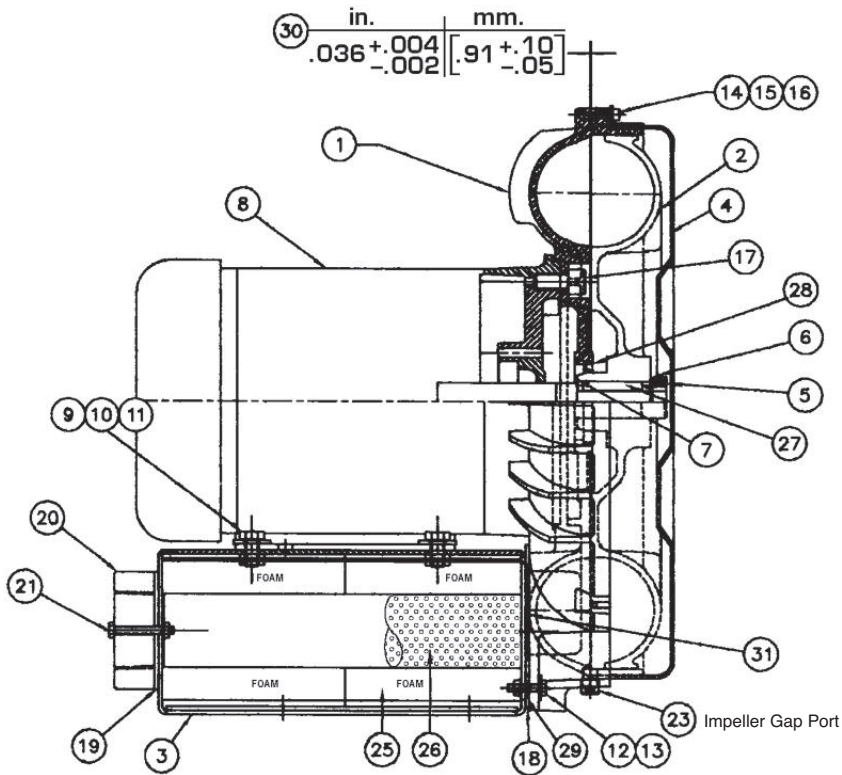

Parts List

DESCRIPTION: VORTEX BLOWER ASSEMBLY – VB037S, VB037, VB037XP			
ITEM	PART NO.	DESCRIPTION	QTY.
1	VBC93701	Case	1
2	VB193702	Impeller	1
3	VBB93700	Base	1
4	VBE93701	Cover, Impeller	1
5	NUT90209	Locknut, Shaft	1
6	WSH90172	Lockwasher, Shaft	1
7	WSH90157	Shim, Shaft to Impeller (as required)	1
8	MOT90361	Motor, 184TC, 5 HP, 1PH, 50/60Hz	1
8A	MOT90181	Motor, 184TC, 5 HP, 3PH, 50/60Hz	1
8B	MOT90234	Motor, 184TC, 5 HP, 3PH, 575 Volt, 50/60Hz	1
8C	MOT90222	Motor, 184TC, 5 HP, 3PH, XP, 50/60Hz	1
8D	MOT90480	Motor, 184TC, 5 HP, 3PH, 60Hz	1
8E	MOT90479	Motor, 184TC, 5 HP, 1PH, 60Hz	1
9	SCR90879	M8 x 1.25 Hex Head Bolt x .98 [25] Long	4
10	WSH90148	Lockwash, M8	4
11	WSH90182	Flat Washer, M8	4
12	SCR90878	M6 x 1.0 Hex Head Bolt x 1.57 [40] Long	2
13	WSH90166	Flat Washer, M6	2
14	SCR90877	M5 x 0.8 Pan Head Phillips Screw x .39 [10] Long	4
15	WSH90138	Lockwasher, M5	4
16	WSH90139	Flat Washer, M5	4
17	SCR90335	1/2-13 x 1.0 Long Socket Cap Screw	4
18	GSK90154	Gasket, Case	1
19	GSK90155	Gasket, Flange	2
20	FLC90009	Flange, 2 FNPT	2
21	SCR90878	M6 x 1.0 Hex Head Bolt x 1.57 [40] Long	4
23	PLG90037	Plug, 1/4 NPT x .43 [11] Long	1
25	INS90021	Absorber	4
26	SCN90056	Absorber Screen	2
27	KEY90079	Key	1
28	SEL90104	Lip Seal	1
29	SPR90088	Spacer, Washer (Case to Base)	2
30	N/A	Impeller to case gap specification	N/A
31	PLC90027	Plate, Case	1

(See Bulletin 417, pages 40 and 41 for specifics on models with explosion-proof motors.)

VB037S, VB037

Performance Curves

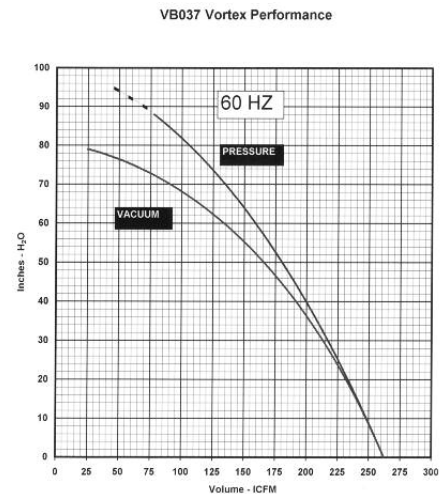

VB037 Vortex Performance

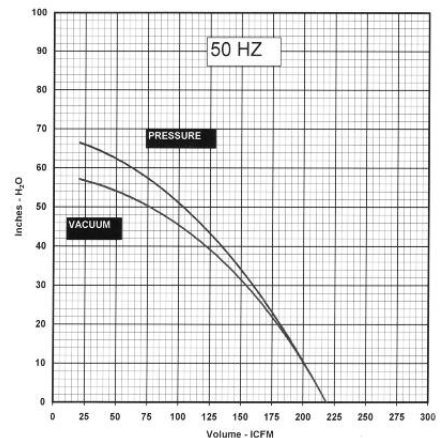

Spencer® Vortex® Regenerative Blowers

VB055, VB055XP

Assembly Diagram

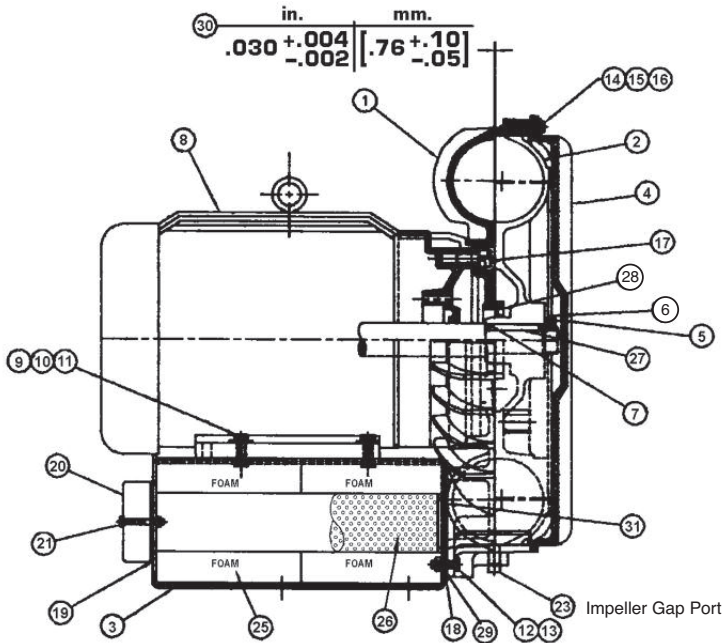

(See Bulletin 417, pages 42 and 43 for specifics on models with explosion-proof motors.)

Parts List

DESCRIPTION: VORTEX BLOWER ASSEMBLY – VB055, VB055XP			
ITEM	PART NO.	DESCRIPTION	QTY.
1	VBC95501	Case	1
2	VBI95502	Impeller	1
3	VBB95501	Base	1
4	VBE95501	Cover, Impeller	1
5	NUT90211	Locknut, Shaft	1
6	WSH90173	Lockwasher, Shaft	1
7	WSH90154	Shim, Shaft to Impeller (as required)	1
8	MOT90182	Motor, 213TC, 7-1/2 HP, 3PH, 50/60Hz	1
8A	MOT90205	Motor, 213TC, 7-1/2 HP, 3PH, 575 Volt, 50/60Hz	1
8B	MOT90221	Motor, 213TC, 7-1/2 HP, 3PH, XP, 50/60Hz	1
8C	MOT90481	Motor, 213TC, 7-1/2 HP, 3PH, 60Hz	1
9	SCR90881	M8 x 1.25 Hex Head Bolt x 1.18 [30] Long	4
10	WSH90148	Lockwasher, M8	4
11	WSH90182	Flat Washer, M8	4
12	SCR90895	M8 x 1.25 Hex Head Bolt x 1.57 [40] Long	2
13	WSH90182	Flat Washer, M8	2
14	SCR90876	M6 x 1.0 Hex Head Screw x .98 [25] Long	8
15	WSH90143	Lockwasher, M6	8
16	WSH90142	Washer, Flat M6	8
17	SCR90335	1/2-13 x 1.0 Long Socket Cap Screw	4
18	GSK90156	Gasket, Case	1
19	GSK90157	Gasket, Flange	2
20	FLC90010	Flange, 2-1/2 FNPT	2
21	SCR90878	M6 x 1.0 Hex Head Bolt x 1.57 [40] Long	4
23	PLG90037	Plug, 1/4 NPT x .43 [11] Long	1
25	INS90022	Absorber	4
26	SCN90057	Absorber Screen	2
27	KEY90080	Key	1
28	SEL90105	Lip Seal	1
29	SPR90089	Spacer Washer (Case to Base)	2
30	N/A	Impeller to case gap specification	N/A
31	PLC90028	Case Plate	1

VB055

Performance Curves

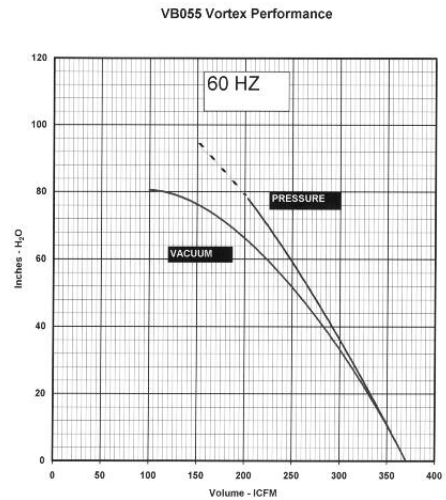

VB055 Vortex Performance

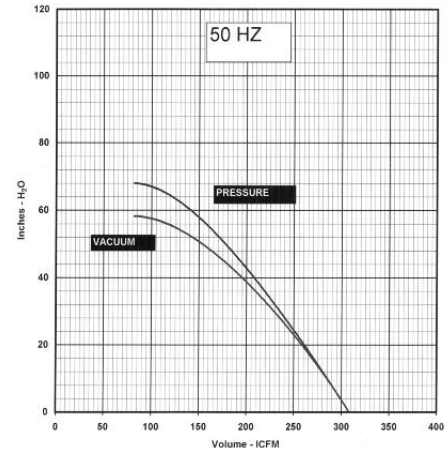

Spencer® Vortex® Regenerative Blowers

VB075, VB075XP

Assembly Diagram

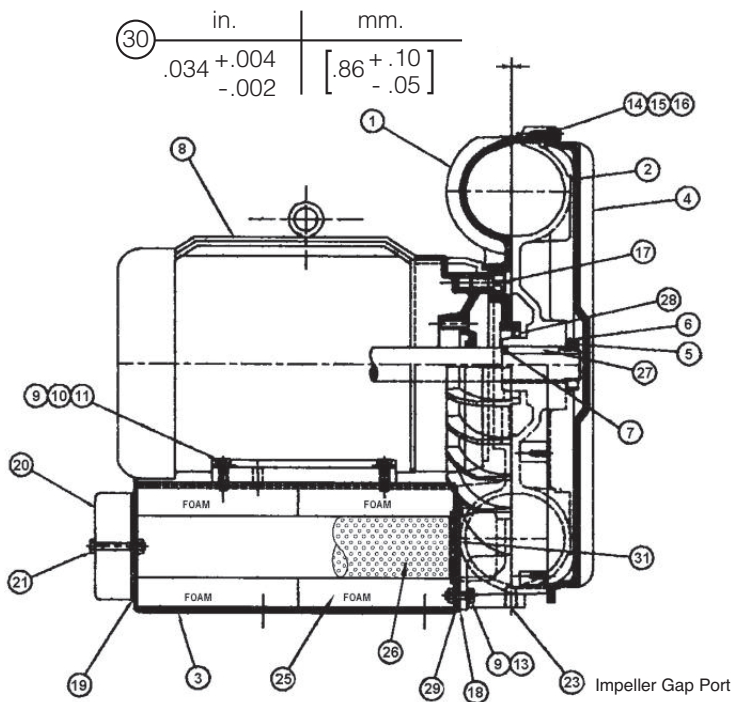

(Contact factory for specifics on models with explosion-proof motor.)

Parts List

DESCRIPTION: VORTEX BLOWER ASSEMBLY – VB075, VB075XP			
ITEM	PART NO.	DESCRIPTION	QTY.
1	VBC97501	Case	1
2	VB197502	Impeller	1
3	VBB97501	Base	1
4	VBE97501	Cover, Impeller	1
5	NUT90213	Locknut, Shaft	1
6	WSH90174	Lockwasher, Shaft	1
7	WSH90179	Shim, Shaft to Impeller (as required)	1
8	MOT90199	Motor, 215TC, 10 HP, 3PH, 50/60Hz	1
8A	MOT90235	Motor, 215TC, 10 HP, 3PH, 575 Volt, 50/60Hz	1
8B	MOT90220	Motor, 215TC, 10 HP, 3PH, XP, 50/60Hz	1
8C	MOT90482	Motor, 215TC, 10 HP, 3PH, 60Hz	1
9	SCR90881	M8 x 1.25 Hex Head Bolt x 1.18 [30] Long	4
10	WSH90148	Lockwasher, M8	4
11	WSH90182	Flat Washer M8	4
12	SCR90881	M8 x 1.25 Hex Head Bolt x 1.18 [30] Long	2
13	WSH90182	Flat Washer M8	2
14	SCR90876	M6 x 1.0 Hex Head Screw x .98 [25] Long	8
15	WSH90143	Lockwasher, M6	8
16	WSH90142	Flat Washer M6	8
17	SCR90335	1/2-13 x 1.0 Long Socket Cap Screw	4
18	GSK90158	Gasket, Case	1
19	GSK90159	Gasket, Flange	2
20	FLC90011	Flange, 3 FNPT	2
21	SCR90883	M8 x 1.25 Hex Head Bolt x 2.165 [55] Long	4
23	PLG90037	Plug, 1/4 NPT x .43 [11] Long	1
25	INS90023	Absorber	4
26	SCN90058	Absorber Screen	2
27	KEY90081	Key	1
28	SEL90106	Lip Seal	1
29	SPR90089	Spacer, Washer (Case to Base)	2
30	N/A	Impeller to case gap specification	N/A
31	PLC90029	Case Plate	1

VB075

Performance Curves

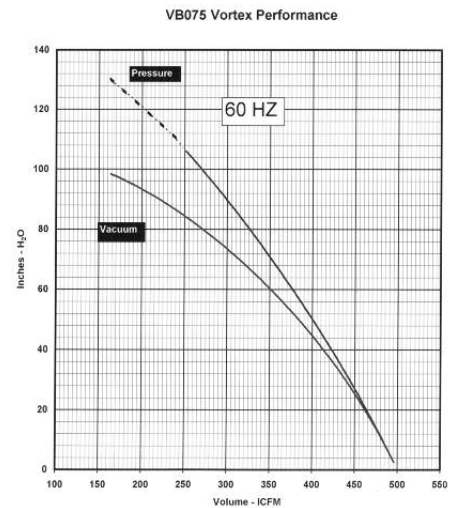

VB075 Vortex Performance

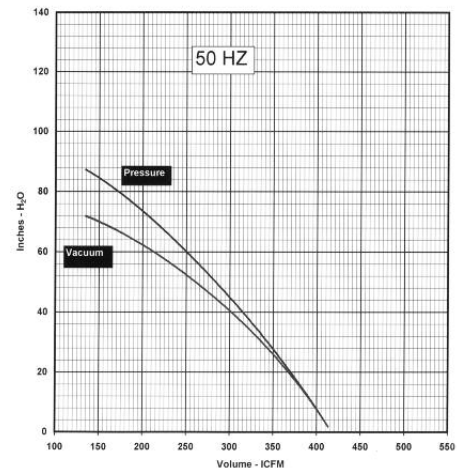

Spencer® Vortex® Regenerative Blowers

VB110, VB110XP

Assembly Diagram

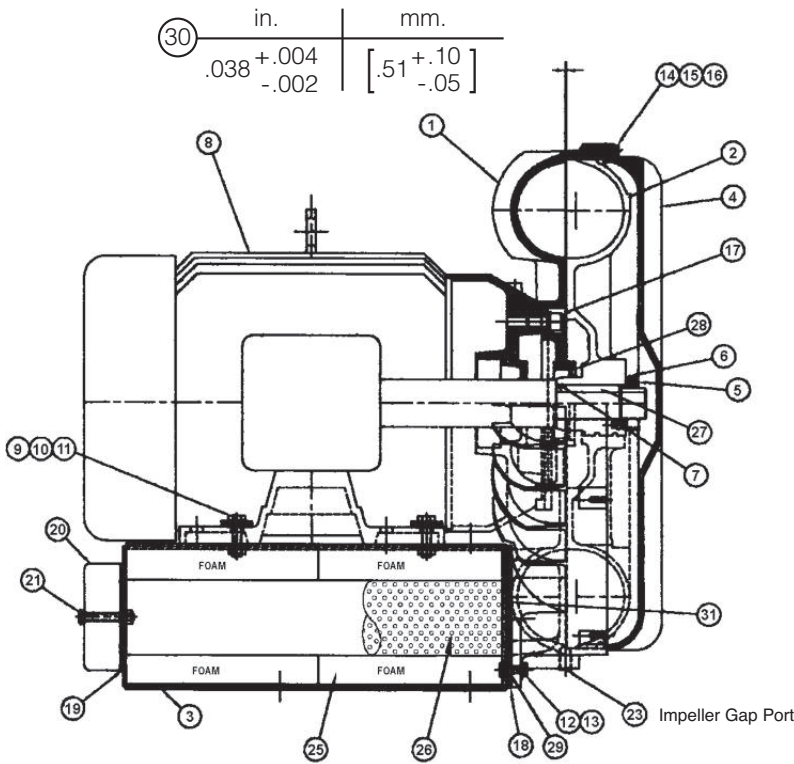

(Contact factory for specifics on models with explosion-proof motor.)

Parts List

DESCRIPTION: VORTEX BLOWER ASSEMBLY -- VB110, VB110XP			
ITEM	PART NO.	DESCRIPTION	QTY.
1	VBC91101	Case	1
2	VBI91102	Impeller	1
3	VBB91101	Base	1
4	VBE91101	Cover, Impeller	1
5	NUT90213	Locknut, Shaft	1
6	WSH90174	Lockwasher, Shaft	1
7	WSH90179	Shim, Shaft to Impeller (as required)	1
8	MOT90200	Motor, 254-6TC, 15 HP, 3PH, 50/60Hz	1
8A	MOT90236	Motor, 254-6TC, 15 HP, 3PH, 575 Volt, 50/60Hz	1
8B	MOT90219	Motor, 254TC, 15 HP, 3PH, XP, 50/60Hz	1
8C	MOT90483	Motor, 254TC, 15 HP, 3PH, 60Hz	1
9	SCR90882	M10 x 1.5 Hex Head Bolt x 1.57 [40] Long	4
10	WSH90137	Lockwasher, M10	4
11	WSH90183	Flat Washer M10	4
12	SCR90881	M8 x 1.25 Hex Head Bolt x 1.18 [30] Long	2
13	WSH90182	Flat Washer M8	2
14	SCR90876	M6 x 1.0 Hex Head Screw x .98 [25] Long	8
15	WSH90143	Lockwasher, M6	8
16	WSH90142	Flat Washer M6	8
17	SCR90335	1/2-13 x 1.0 Long Socket Cap Screw	4
18	GSK90160	Gasket, Case	1
19	GSK90159	Gasket, Flange	2
20	FLC90011	Flange, 3 FNPT	2
21	SCR90883	M8 x 1.25 Hex Head Bolt x 2.16 [55] Long	4
23	PLG90037	Plug, 1/4 NPT x .43 [11] Long	1
25	INS90024	Absorber	4
26	SCN90061	Absorber Screen	2
27	KEY90082	Key	1
28	SEL90106	Lip Seal	1
29	SPR90089	Spacer, Washer (Case to Base)	2
30	N/A	Impeller to case gap specification	N/A
31	PLC90030	Case Plate	1

VB110

Performance Curves

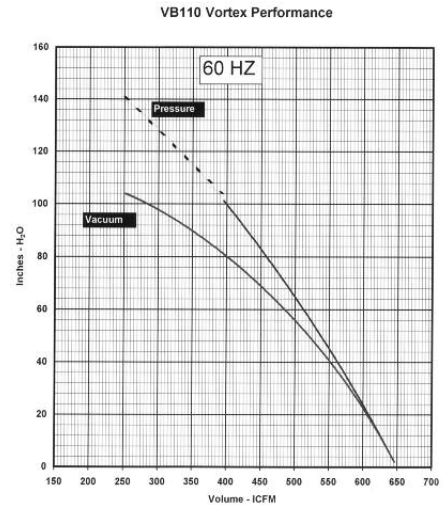

VB110 Vortex Performance

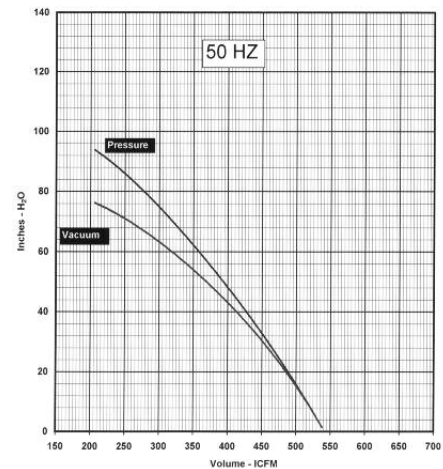

VI. Troubleshooting Guide

Trouble	Possible Cause	Corrective Action
Blower Does Not Turn and there is -		
A Humming Sound	<ul style="list-style-type: none"> - One phase of power line disconnected - One phase of stator line open - Bearing(s) defective - Impeller jammed by foreign material - Impeller jammed against casing or side cover - Rubbing of rotor core and stator core - Capacitor open (single-phase models) 	<ul style="list-style-type: none"> Connect power leads properly Contact factory Change defective bearing(s) Clean impeller Adjust gap Contact factory Change capacitor
No Sound	<ul style="list-style-type: none"> - Two phases of power line disconnected - Two phases of stator winding open - Faulty switch connection - Fuse blown 	<ul style="list-style-type: none"> Connect power leads properly Contact factory Change switch Change fuse
Blower Turns, but -		
Fuse Blows	<ul style="list-style-type: none"> - Fuse capacity insufficient, wiring fault - Short circuit - Terminals shorted - Excessive load 	<ul style="list-style-type: none"> Inspect wiring Repair Improve insulation and check connections Increase air flow
Overheats or Thermal Protector Activates		
	<ul style="list-style-type: none"> - Power source unbalance; possible voltage drop - Operating in single-phase condition - Excessive friction due to defective bearings - Impeller contaminated by foreign material - Impeller rubbing against casing or side cover - Operation at less than minimum rated flow - Inlet air filter clogged 	<ul style="list-style-type: none"> Check voltage; phases must be balanced within 5% and voltage must be within 10% of rated Check connections Replace bearings Clean impeller Adjust gap Increase air flow Clear or replace element
Makes Abnormal or Excessive Sound		
	<ul style="list-style-type: none"> - Impeller rubbing against casing or side cover - Impeller rubbed by foreign material - Bearing(s) defective - There is a leak or air passages are clogged - Loose cap screw - Air channel noise absorber foam damaged 	<ul style="list-style-type: none"> Adjust gap Clean impeller Replace bearings Repair or clean Tighten screw Replace absorbers

Customer Maintenance Log

DATE	PROCEDURE	COMMENTS	INITIALS