

ELGITM

Always Better.

EG Series Screw Air Compressor

Operation, Maintenance and Parts Manual



CIN:L29120TZ1960PLC000351

EG 18, Standard + VFD
460V, 3Ph, 60Hz



Product Manual

EG Series

Electric Powered Screw Air Compressor

EG 18 - 125.0

Air - Cooled, Standard + VFD
460V, 3Ph, 60Hz

©

ELGI EQUIPMENTS LIMITED

Coimbatore, TN - 641 005

Part / Document No. 019000685

Contact Info:

ELGI EQUIPMENTS LIMITED

Coimbatore, TN - 641 005, India

Tel : 91 - 422 2589555

Fax : 91 - 422 2573697 (Domestic Business)

Fax : 91 - 422 2589401 (International Business)

E-mail : enquiry@elgi.com

Website : www.elgi.com

Machine Identification and Sale Record



Owner's name / Company name :

Phone number :

Contact person :

E-Mail address/
Phone number :

Model :

Fab. No. :

Year of manufacture :

Motor : kW (HP)

Capacity : m³/min (cfm)

Rated pressure : bar.g (psi.g)

Date of delivery :

Date of commissioning :

Dealer name/address :

Dealer's signature :

NOTE The warranty on the compressor is valid only if all the details above are filled in and the dealer stamps and signs this page. This report must reach the Regional Office/Head Office of ELGi within seven days of commissioning date.

	Chapter	Page No.
1.0	About ELGi	1.7
2.0	General functional description	2.1
3.0	GA drawing, P&I diagram	3.1
4.0	Technical data	4.1
5.0	Installation and operation	5.1
6.0	Maintenance	6.1
7.0	Controller	7.1
8.0	Air inlet and control system	8.2
9.0	Drive system	9.1
10.0	Discharge system	10.1
11.0	Cooling system	11.1
12.0	Lubrication system	12.1
13.0	Base and canopy system	13.1
14.0	Spare kit details	14.1
15.0	Electrical drawings	15.1
16.0	VFD setting details	16.1

ELGi, established in 1960, designs and manufactures a wide range of air compressors. The company has gained its reputation for design and manufacture of screw compressors through strategic partnerships and continuous research and development. Over the years, it has emerged as a multi-product, multi-market enterprise providing total compressed air solutions to all segments. ELGi's design capabilities translated into a wide range of products ranging from oil-lubricated and oil-free rotary screw compressors, reciprocating compressors and centrifugal compressors.

ELGi is one of the few companies in the world capable of manufacturing wide range of air ends and compressor packages. ELGi has most modern manufacturing facilities with high precision grinding machines, turning centres, CNC horizontal and vertical machining centres and also the latest self measurement technology to maintain precise, aerospace manufacturing tolerances. ELGi's manufacturing plants are ISO and EOHS certified.

Over two million ELGi compressors are powering business in 70+ countries worldwide. The company offers a strong sales and service network with a well-knit distribution network of dealers and distribution, worldwide. ELGi has its own manufacturing operations in India, Italy and USA with subsidiary offices in Australia, Bangladesh, Brazil, China, Indonesia, Italy, Malaysia, Middle East, Sri Lanka and Thailand. The company is fast expanding its global footprint, attracting distributors and customers with its new generation products.

Need help...?

In India

You can contact ELGi customer care system (ECCS) to take care of customer complaints. The ELGi CCS works for six days a week from 08:30 to 21:30 IST (Monday to Saturday). The complaints can be logged by calling any of the following toll free numbers or by e-mail.

Toll free : **1800 425 3544**

E-Mail : ccs@elgi.com

Website : www.elgi.com

Before making service request for your compressor, keep ready the details printed on the name plate of the compressor and machine identification and sale record of this manual. When ordering spare parts, refer to the lists provided in the parts manual and identify the part number. Specify the part number and quantity, in addition to the name plate details.

Refer "ELGi services" for more details about ECCS under chapter "Maintenance".



2.0 General functional description

Contents	Page No.
2.1 Using the manual	2.2
2.1.1. Definitions and symbols	2.2
2.2 Introduction	2.3
2.3 Safety	2.4
2.3.1 Precautions during installation	2.4
2.3.2 Precautions during operation	2.5
2.3.3 Precautions during maintenance	2.7
2.4 Functional description	2.9
2.4.1 Air circuit	2.9
2.4.2 Oil circuit	2.9
2.4.3 Drive system	2.9
2.4.4 Control system	2.10
2.4.5 For retro-fitment of Standalone VFD with Compressor (C) version in field	2.10

2.1 Using the manual

This operation and maintenance manual has been specially designed keeping the customer in mind so that the person can get the most out of this EG compressor. Before starting the compressor, it is requested that the manual should be read thoroughly. It contains vital information about installation, commissioning, operation and useful tips on maintenance to keep the compressor as good as new, year after year. The manual has been prepared with utmost care to help you understand the various systems of the compressor, along with descriptions, information and illustrations.

Following chapters are provided to help operate the compressor in its best way.

- **Safety** - safety precautions that must be followed while using the compressor.
- **Technical specifications** - technical details about the compressor.
- **Installation and commissioning** - all site requirements, procedures to be followed during installation, commissioning, preservation etc.
- **Functional description** – parts, their function and working.
- **Operating instructions** – to operate the compressor properly.
- **Maintenance** – how to do the maintenance for the compressor and their intervals.
- **Troubleshooting** – identification and solving the problems.
- **Decommissioning** – how to decommission the compressor, its disposal etc.
- **ELGi services** – services from ELGi: CCS, air audit, spare parts
- **Appendix** – conversion tables, torque values, service log book

Refer to the parts manual to identify the part number of the required spare. Mention the Fab number, model and part number while ordering.

This manual must be made available to the compressor operating and maintenance personnel at all times.

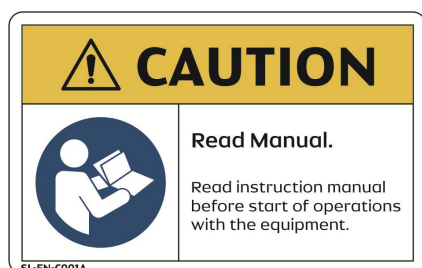

2.1.1 Definitions and symbols

This information is related to your safety and also to prevent any problems relevant to the equipments used. To help recognize this information better, the symbols are illustrated in section "safety".

All the information, illustrations and specifications in this manual are based on the latest product information at the time of preparation of the manual. Product improvement is a continuous process in ELGi. The details in this manual are likely to change without notice and ELGi reserves the right to incorporate such changes.

NOTE

Note clarifies procedures or conditions which may otherwise be misinterpreted or overlooked. Note may also be used to clarify apparently contradictory or confusing situations.

WARNING

Warning calls attention to dangerous or hazardous conditions inherent to the operation, cleaning and maintenance of the compressor which may result in fatal accident and personal injury of the operator or other staff

CAUTION

Caution is to draw attention to a procedure which, if not done correctly can lead to compressor damage.

Welcome to ELGi customer family. ELGi compressors are the source of compressed air in various segments across the globe.

ELGi compressors are known for

- Greatest reliability
- Fewer maintenance interval
- Ease of use
- Highest safety

ELGi screw compressor is designed to give

- High energy efficiency
- Low maintenance cost
- High discharge air quality

All the above assures a low life-cycle cost.

The rotors incorporate a specially designed **eta-v profile** – ELGi patented profile-which emphasizes on improving reliability, performance and efficiency. Eta-v profile is the latest and the most energy efficient profile in the industry globally, assuring consistent performance during entire life of the compressor. ELGi screw air compressors have a compact design and compressor run with low noise or vibrations. The capacity control system ensures optimum air intake during start up, normal running and unloading stages, minimizing power consumption. The oil separation system ensures that maximum oil is separated from the compressed air, ensuring the best air quality with very little oil carry-over.

Uptime

At ELGi, we are changing the way you look at compressed air systems. It's no longer just about delivering air. It's about delivering uptime. Our uptime design ensures that the compressors would run cooler, cleaner and longer with longer service intervals. The uptime components are best in quality keeps your compressor to run smoothly, efficiently and profitably. With uptime assurance we back our pledge, with industry-leading warranties, parts availability, loaner compressors and call centres staffed by experts. We thank you for purchasing ELGi compressor and assure you the best service during entire life of compressor.

EG Series

Your EG Series compressor belongs to a family of rotary screw compressors from ELGi. The compressor has only two moving parts: the two rotors. A thin film of oil separates the rotors to prevent wear. This also means that the reliability of the compressor is unsurpassed.

The screw compressor technology ensures that output capacity never diminishes even after many years of operation. It involves a continuous flow of air through helical cavities in the screw, ensuring pulsation-free compressed air delivery.

The design of the EG Series gives you a compact and self-contained compressor. Because it contains no reciprocating parts, it runs quietly and free of vibrations. The discharge temperature of the coolant oil is low, less than 90°C (195°F), under normal conditions and therefore prevents carbonized oil from forming in the compressor.

Salient Features

- Three-stage air filtration
- Improved air filter life cycle
- Noise-free package suitable for in-house operations
- Variable capacity control system*
- High volumetric efficiency
- Efficient air-oil separation by OSBIC (Oil Separation By Impact and Centrifugal action)
- Reliable fan that works even at high temperature
- Isolated cooling system
- Robust cooling system
- Industrial designed canopy
- Compact and hardly space-intensive
- Split type oil & after coolers for easy serviceability
- Flush type panels for easy handling
- Anti-vibration mounts for restricted vibration
- Increased life of consumables
- Integrated VFD (Variable Frequency Drive) and dryer*.
- Zero-leak flanged joints.
- Oil carry over < 1 ppm
- Advanced Neuron controller
- Globally certified product - CE / UL and other country specific approvals.

* For selected models.

The operator must follow the safe working practices, instructions, procedures that this manual describes for safe operation. The maintenance personnel must be adequately trained, and have read and thoroughly understood this 'Operation and maintenance manual'. Decals are affixed at specific locations of the compressor and they illustrate very important safety precautions.

2.3.1 Precautions during installation

- Ensure that you fasten all loose parts before lifting. Select the appropriate lifting equipment by considering the local safety regulations, size and weight of the compressor. Operate the lifting equipment carefully within the safe operating limits. Ensure all necessary personal protective equipment's (PPEs) is close at hand during this operation.



- Maintain a cool and clean ambient for the compressor and ensure that the air inlet is not obstructed. Make arrangements to reduce the moisture entry through the incoming air.
- Remove protection such as caps, plugs, desiccant bags before connecting the air line pipes.
- Remove the red colored protective clamps from the aircend and motor while commissioning the compressor.



- Do not use frayed, damaged or worn hoses. Distribution pipes and connections must be of the correct size and suitable for working pressure.
- Make sure that the aspirated air by the compressor is free of flammable fumes, vapors and particles, to prevent internal fire or explosion.
- For remotely controlled compressors and auto-start compressors, provide a clear caution stating: **"DANGER" – Remotely controlled machine and will start without notice**



- Ensure the operator is located far away from the intake of the compressor.
- Position the after-cooler discharge pipe in a way that it is free to expand under heat and is not in contact with or close to flammable materials.
- Do not exert external force on the air outlet valve and keep the connected pipe always free of strain.
- Make available adequate cooling air must be made available for the compressor particularly air cooled compressors. Make sure that exhausted air does not circulate back to the intake or cooling system.
- Make the electrical connections according to the legal standards and earth the compressor suitably. Provide a sufficient number of fuses and other protective devices to protect the compressor against short circuits. Good practice is to provide an isolating switch nearby the compressor.
- Install manual valves behind non-return valves (NRV) to isolate each compressor in multi-compressor systems. Do not rely on NRV for isolating pressure systems.
- Do not bypass, remove or adjust the safety devices or other attachments residing on the compressor. Every installed pressure vessel or auxiliary outside the compressor should have pressure relieving device or devices, as required.

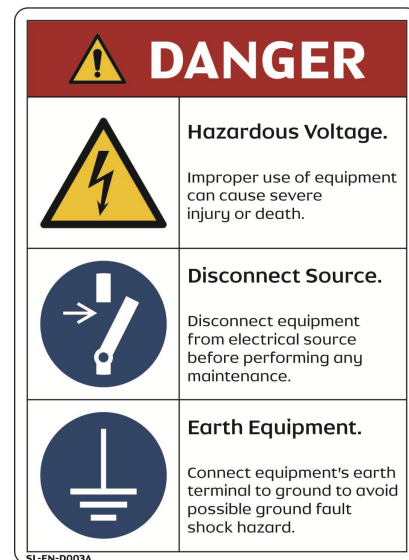

- Danger! Be aware that compressed air used for breathing or food processing must meet O.S.H.A.

1910.134 or F.D.A. 21 C.F.R. 178.3570 regulations. Failure to do so may cause severe injury or death.

- Insulate or use protective guards to cover pipes or other parts that may exceed 80°C (176°F). High-temperature pipes must have a clear marking as potentially dangerous.
- Position the compressor on level surface. In case of inclined surface, contact ELGi.
- Do not allow compressed air to come in contact with food and related items unless they are compressed air-treated specifically.
- Be aware that this air compressor is intended for generating only industrial-use compressed air.

2.3.2 Precautions during operations

- When switching on remotely controlled compressors ensure that no one is checking or working on the compressor at that time.
- Before starting, ensure that no tools or any loose parts remain inside the compressor.
- Do not operate the compressor if a possibility exists that it could inhale flammable or toxic fumes, vapors or particles.
- Do not operate the compressor below or above its operating limits.
- Wear ear protectors if you work in an environment where the sound pressure level reaches or exceeds 90 dB (A).
- Keep all the compressor doors shut during operation. For carrying out routine checks, the doors should open only for short durations not more than 10 minutes. Wear ear protectors when opening a door.
- Keep hands, feet, floors, controls and walking surfaces clean and free of water or other liquid to minimize the possibility of slips and falls.

Pressure release

- Know that annual servicing of the safety valve is necessary. It should be checked at the prescribed pressure for operation.
- Use correct tools for maintenance and repair work. Do not allow the manufacturers' rated safe operating pressure to exceed for pipes, valves, filters and other fittings.
- It is hazardous to point the compressed air directly towards any personnel. Keep personnel out of the line of the discharge air when opening hoses or other points of compressed air discharge.
- Use only the correct type and size of hose end fittings and connections. When blowing through a hose or airline ensure that the open end stays securely. A free end will whip and may cause injury. Make sure to

depressurize a hose fully before disconnecting it.

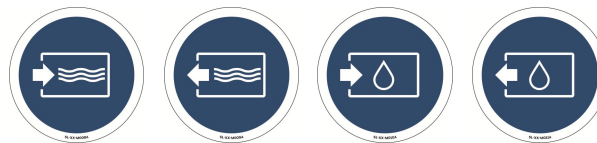

- Release all the pressure in the compressor system before servicing or performing any maintenance activity.
- Do not engage in horseplay with air hoses. Serious injury or death may result.
- Do not use air at a pressure greater than 2.5 bar.g (36 psi.g) for cleaning purpose.
- Open the oil fill cap only when the compressor is not running and is not pressurized. Shut down the compressor and bleed the receiver tank to zero internal pressure before removing the cap.

Fire and explosion



- Clean up spills of lubricants or other combustible substances immediately.
- Shut down the compressor and allow it to cool down before checking or adding oil. Remove sparks, flames and other sources of ignition away from the compressor.
- Do not permit smoking in the vicinity of the compressor.
- Do not use flammable solvents for cleaning purposes.
- Keep electrical wiring and other terminals in good condition. Replace any wiring that has cracked, cut, abraded or otherwise degraded insulation. Keep all terminals clean and tight.
- Keep grounded conductive objects such as tools away from exposed live electrical parts like terminals to avoid arcing, which might serve as a source.
- Keep oily rags, trash, dry leaves, litter or other combustibles out of and away from the compressor.
- Do not operate the compressor without a proper flow of cooling air or with an inadequate flow of lubricant or with a degraded lubricant.
- Do not attempt to operate the compressor in a hazardous environment of any classification unless the compressor has been specially designed and manufactured for explosive applications.

Moving Parts



- Rotating fan blades can cause serious injury. Disconnect power supply before attempting service.
- Keep compressor doors closed except when servicing or during maintenance. The sound damping material on the inner side of the compressor body should not be removed or tampered with.
- Wear snug-fitting clothing and tie long hair when working around the compressor, especially when hot or moving parts such as the cooler, the airend, the thermal valve, the main motor or the fan motor are exposed.
- Keep hands, arms and clothing away from couplings, fans/belts and other moving parts.
- Do not attempt to operate the compressor with the fan guards, coupling guards/belt guards or other guards removed.



- Keep hands, feet, floor, controls and walking surfaces clean and free of fluid, water or other liquids to minimize the possibility of slips and falls.

Hot surfaces



- Avoid bodily contact with hot oil and hot surfaces like cooler, pipes etc.
- Keep all parts of the body away from all points of air discharge.
- Keep a first aid kit handy. Seek medical assistance promptly in case of injury. Do not ignore small cuts and burns.

Toxic and irritating substances

- Do not use air from the compressor for breathing.
- Always wear safety equipment while operating the compressor. Refer OSHA safety standards.
- Do not allow compressed air to come into contact with any edible items.
- In the event of ingestion of oils, coolants or lubricants used in the compressor, seek medical treatment promptly. In case you come in contact with such substances, wash with soap and water. Use MSDS for oil to know more on this.
- If warm cooling air from the compressor is being used in air heating systems, e.g. to warm up a work room, take precautions against air pollution and possible contamination of the breathing air.

Electric shock

- Keep all parts of the body and any handheld tools or other conductive objects away from exposed live parts of the electrical system.
- Stand on a dry or insulating surface and do not contact any other part of the compressor when making adjustments or repairs to exposed live parts of the electrical system.

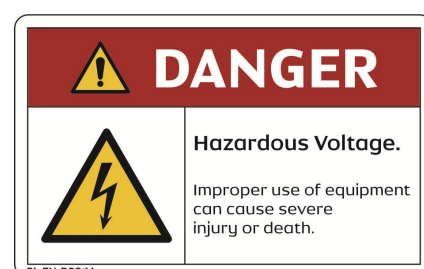

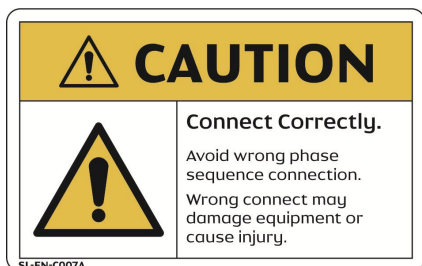

- Before switching on the compressor ensure that proper earthing is done as per recommendation.
- Make all adjustments or repairs with one hand. This minimizes the risk of creating a current path through the heart.
- Conduct repairs only in a clean, dry, well-lit and ventilated area.
- Do not leave the compressor unattended with open electrical enclosures. If necessary to do so, disconnect the power to the compressor at the source and lock it out so that power is not inadvertently restored.
- Disconnect, lock out, and tag the power source prior to attempting repairs or adjustments, turning the compressor manually or handling ungrounded conductors.
- All electrical installation must be in accordance with recognized electrical codes and any local health & safety codes.
- Recognize that only authorized and qualified trained personnel should carry out any electrical work on the compressor.
- Regularly check that all electrical connections are tight and in good condition.

Periodically check whether

- All guards are in place and securely fastened.
- All hoses and pipes inside the compressor are in good condition, secure and not rubbing against each other.
- Any leaks exists.
- All fasteners are tight.
- All electrical leads are secure and in good order.
- Safety valves and other pressure relief devices are not obstructed by dirt or paint.
- Air outlet valve, i.e. pipes, couplings, manifolds, valves, hoses, etc. are in good repair, free of wear or abuse.
- The air-oil tank is properly grounded.

2.3.3 Precautions during maintenance

- Use safety glasses and incorporate safe working practices before maintenance work.
- Use appropriate tools for all maintenance works.

- Use only genuine spare parts. Refer the **section "Use genuine spare parts"** in **"Maintenance"** chapter.

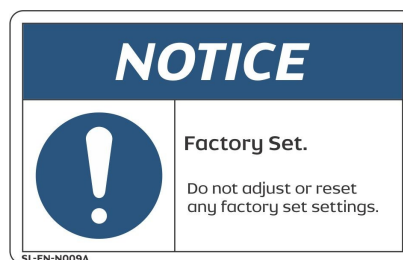

- Ensure that the compressor is cooled down before maintenance is performed.

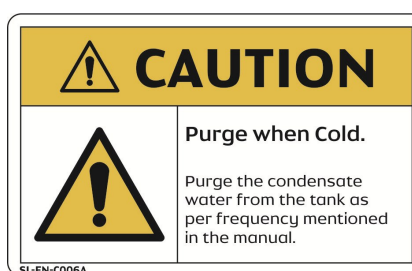

- Springs under tension or compression store energy. Uncontrolled release of this energy can cause serious injury or death. Be cautious while performing the maintenance of components loaded with springs (for example minimum pressure valve, safety valve etc.).
- Display a warning sign that says **"Maintenance under progress, don't switch on"** near the start switch.
- Isolate the compressor from the air line (discharge) and disconnect the power by opening and locking the isolating switch before maintenance.
- Prior to attempting repairs or adjustments, disconnect the power at the source and verify at the compressor that the circuits have de-energized. This minimizes the possibility of accidental start-up or operation, especially when the compressor is remotely controlled.
- Open the oil filler cap only when the compressor is not running and is not pressurized. Shut down the compressor and bleed the receiver tank to zero internal pressure before removing the cap.

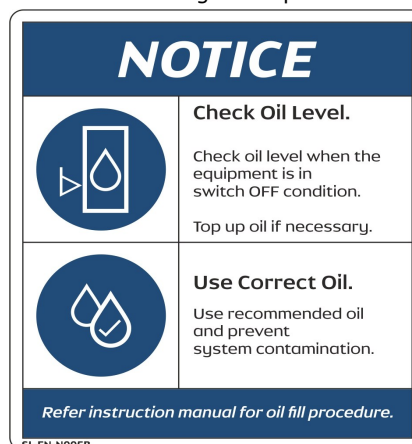

- If you are going to switch on remotely controlled compressors must ensure that nobody is checking or working on the compressor at that time. A warning sign near the equipment's start button is mandatory.
- Wait up to five minutes to ensure that the air in the air-oil separator tank is released to start routing maintenance.

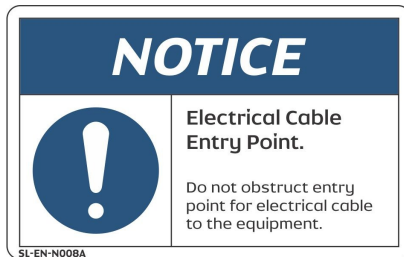

- Vent all internal pressure prior to opening any line, fitting, valve, drain plug, connection or other components such as filters. Vent pressure by popping up the safety valve.
- Display a maintenance chart near the compressor to easily identify the maintenance intervals of regular service items.

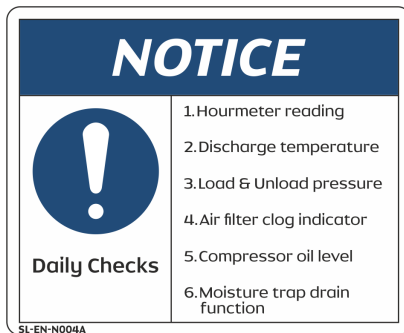

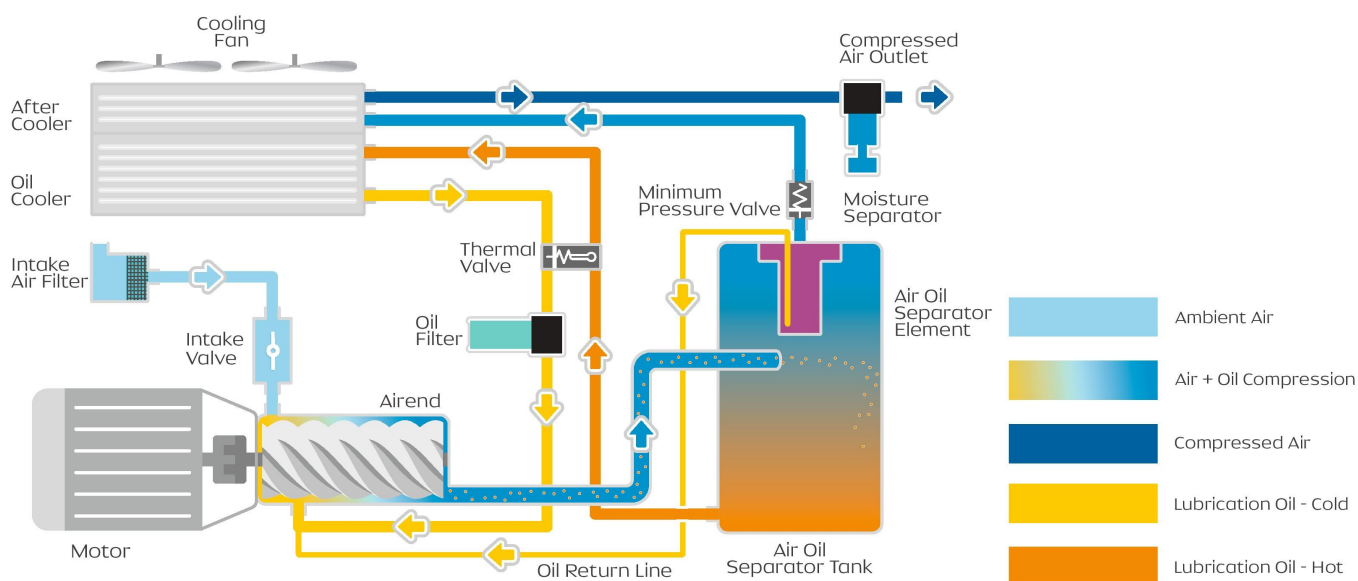

Figure 1. Screw compressor systems - Schematic diagram

2.4.1 Air circuit

The atmospheric air enters into the airend through the air intake system. The intake filters (pre filter and air filter) prevents the entry of foreign particles (such as dust) into the airend. The intake valve regulates the amount of air sucked into the airend. The opening and closing of the intake valve are controlled by the pneumatic pulse line actuated by an electrically controlled solenoid valve. The clog indicator fitted in the air filter turns red when the filter is clogged.

The filtered air enters into the airend where it mixes with the injected oil. The injected oil acts as a coolant to maintain optimum temperature. It also seals the leaks between the rotors and the housing and lubricates the bearings and gears. The airend consists of two counter-rotating intermeshed helical screws - the male and the female rotors - which are driven by electric motor. The air-oil mixture is trapped between the rotors of the airend and is progressively compressed.

After being compressed, the air-oil mixture enters with high velocity into the air-oil separator tank where it undergoes a unique 3 stage separation process which removes maximum oil content. This highly efficient 3 stage separation process uses the impact velocity of air-oil mixture along with centrifugal action, which makes the mixture very lean. The final stage of this separation consists of passing the lean mixture through the air-oil separator element which leaves the air with an oil content of < 1 ppm.

The oil separated and collected in this element is then returned to the airend through the oil return line. The air passes through a minimum pressure valve (MPV). It maintains a minimum differential pressure which is required for circulation of oil within the compressor unit. The compressed hot air is cooled in the after cooler and is

separated of any moisture content by the moisture separator. The cooled and moisture free compressed air is now discharged to the external receiver, ready to be used.

2.4.2 Oil circuit

The oil in the air-oil separation tank after being separated is fed into the airend. The oil either gets diverted to the oil cooler or oil filter or both depending upon the temperature. The thermal valve governs and controls the oil flow path. The oil before being injected into the airend is filtered. An orifice is provided in oil flow path towards the airend to control the oil flow. The whole oil circulation circuit in the compressor is operated solely by the differential pressure maintained by the minimum pressure valve (MPV) and doesn't require any additional pump.

2.4.3 Drive system

The airend transmission is powered by an electric induction motor through a coupling. When the compressor is turned ON, the motor is started in star mode and takes 6 to 9 seconds to change over to delta mode. During this period the intake valve remains closed and thus the motor starts without load. In delta mode, the motor speed stabilizes, the solenoid valve energizes after 10 seconds of change-over to reduce load on the motor, the blow down valve is closes, intake valve opens and the compressor starts loading. For compressors with variable frequency drive (VFD), speed of the motor gradually increases within 30 seconds (ramp-up time) while the intake valve remains in the closed position. This ensures very little starting load. Next, the intake valve opens and the system starts building up pressure. An adaptor ring connects the airend and the motor. It also helps in maintaining the coupling alignment. The coupling element acts as a safety interlock and it is the first one to fail when coupling elements become over loaded. This architecture saves the whole drive system from failure. Malfunctioning of the coupling

element will result in noise and vibration. Anti-vibration mountings reside below the air end and the motor. This configuration reduces the transmission of vibration from air end and motor to the structure, reducing noise and ensuring reliability of mounted parts on the structure.

2.4.4 Control system

Load - Unload

Depending on the demand for compressed air from the application at a particular time, the compressor needs to respond accordingly. The compressor, therefore operates in either loading or unloading mode to meet this requirement. The primary objective of these modes is to save energy and reduce wear and tear on the machine. The control system ensures a smooth start without overloading the motor. The compressor is started in star mode, during which most of the compressed air is vented to the atmosphere. This mechanism helps prevent overloading the motor. In delta mode the motor speed stabilizes, the solenoid valve energizes after 10 seconds of change-over to reduce load on the motor, the blow-down valve is closes, and the compressor starts loading.

When the receiver pressure reaches the maximum limit, a signal arrives the solenoid valve from the control system. Next, the inlet valve actuates and closes, and the compressor runs in unloading mode. If unloading mode continues for more than 5 minutes, i.e., compressed air is consumed and thus no decrease in pressure occurs, the system stops and switches to standby mode. If a drop in pressure occurs in the receiver, the compressor returns to loading mode automatically.

Suction modulation

When you operate a compressor without VFD, capacity control occurs via a pressure regulator (for selected models). When the consumption of air is less than the FAD of the compressor, the line pressure will start increasing. Whenever the line pressure goes up constantly beyond the set pressure, the pressure regulator bleeds the excess air to the atmosphere thereby reducing the amount of flow into the actuator. The actuator is spring loaded, which, in turn, closes the intake valve slightly and enables capacity control. Similarly when the consumption of air is more than the FAD, the line pressure starts decreasing and the actuator progressively opens the intake valve. This regulation is called intake modulation by throttling.

VFD modulation

VFD is an efficient way of controlling capacity as per demand. In a compressor with VFD the power of compressor varies proportionally with capacity reduction. The VFD tunes the frequency, thereby adjusting the speed based on the change in line pressure. The incoming flow will automatically reduce because of reduced speed of the motor. Conversely speed increases when line pressure goes down below working pressure.

2.4.5 For retro-fitment of Standalone VFD with Compressor (C) version in field

1. Change the bearings to insulated type for motors $\geq 90\text{kW}$ at Non Drive End side of Motor
2. Turndown only upto 50% for conversion models (considering the motor speed) i.e. motor frequency range is 50 - 25 Hz for 50Hz variant and 60 - 30Hz for 60Hz variant. No pressure turndown is applicable
3. Run the compressor in the VFD operating range (50 to 25Hz) and skip the frequency in VFD controller (within +/- 1Hz) if abnormal noise / vibration is observed
4. Change the thermal element from 65°C to 75°C



4.0 Technical data

Standard, Standard + VFD

Model		-	EG 11				EG 15				EG 18				EG 22			
Working pressure		psi.g	100	125	150	175	100	125	150	175	100	125	150	175	100	125	150	175
FAD - Free air		cfm	71	62	55	49	94	85	77	65	117	110	92	82	143	134	116	96
Delivery		m ³ /min	2.01	1.76	1.56	1.39	2.66	2.41	2.18	1.84	3.31	3.11	2.61	2.32	4.05	3.79	3.28	2.72
Unloading pressure		psi.g	107	132	157	182	107	132	157	182	107	132	157	182	107	132	157	182
Nominal power supply conditions		-	208-230V / 460V (+/-10%), 60Hz(+/-5%),3phase															
Main motor rating		hp	15				20				25				30			
Type of motors (main drive & fan drive)		-	Squirrel Cage Induction-TEFC & Cooling Fan Integrated Motor															
Insulation and protection of main motor		-	Class F & IP55															
Frame size / mounting type		-	254T/L / B35				256T / B35				284T / B35				286T / B35			
Type of starter for main motor	STD	-	Automatic Star Delta															
	STD + VFD	-	Through Variable Frequency Drive															
Maximum fan motor rating per fan X no. of fans		hp	0.38 (208-230V) / 0.40 (460V) X 1 Fan								0.38 (208-230V) / 0.40 (460V) X 2 Fans							
Rated speed of fan motor		rpm	1560 (208V-230V) / 1630 (460V)															
Safety valve set pressure		psi.g	205															

Contents	Page No.
5.1. Installation and commissioning	5.2
5.1.1 Unpacking	5.2
5.1.2 Disposal of packing materials	5.2
5.1.3 Handling the compressor	5.2
5.1.4 Site requirements	5.2
5.1.4.1 Ventilation	5.3
5.1.5 Electricals	5.4
5.1.6 Air pipe dimensions	5.5
5.1.7 Receivers for compressed air systems	5.7
5.1.8 Possible mistakes	5.7
5.1.9 Commissioning procedure	5.7
5.1.10 Oil fill procedure	5.8
5.2. Preservation for long idle storage	5.9
5.2.1 Airend	5.9
5.2.2 Motor	5.9
5.2.3 Air-oil separator tank	5.9
5.2.4 Rubber hoses	5.9
5.3. Operating instructions	5.10
5.3.1 Initial start-up checks	5.10
5.3.2 Initial start-up	5.10
5.3.3 Pre-start checks	5.10
5.3.4 Starting	5.10
5.3.5 During running	5.10
5.3.6 Stopping	5.11
5.3.7 Changing the compressor settings	5.11

Before the new EG series compressor is operated for the first time, it needs to be installed at your site according to ELGi's installation guidelines

5.1.1 Unpacking

Unpack the compressor from the packing case by removing the nails. Unscrew the bolts, holding the compressor to the base of the crate

Once the packing material is removed, check the contents against the packing list. The compressor is shipped with the following

- Key for doors.
- Operation and maintenance manual
- Checklist of parts of the machine
- Electrical drawing

5.1.2 Disposal of packing material

The wood/cardboard used to make the shipping crates of the EG series compressors are biodegradable.

The polyethylene covers wrapped around the compressor and the polystyrene packing provided around the electrical panels are not recyclable. They must be disposed off in accordance with prevailing local environmental laws.

5.1.3 Handling

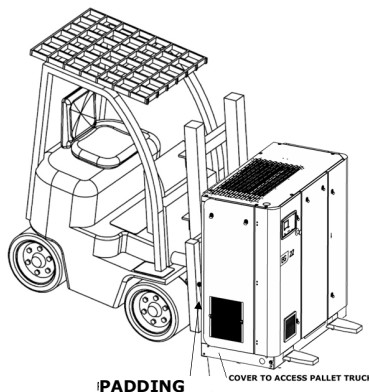

Figure 2. Lifting using forklift

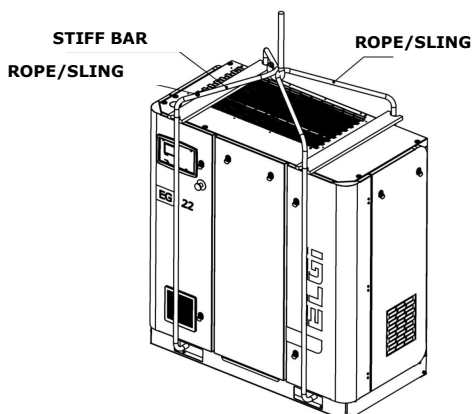

Figure 3. Lifting using crane

- Lifted compressors using either a forklift /pallet truck (Fig.12) or a crane (Fig.13).
- When using a forklift, ensure padding is used in between the compressor and forklift (as shown in Fig.12) to prevent damage to the compressor's canopy.
- When using a crane, please ensure stiff spreader bars are used (as shown in Fig.13) to prevent rope slings from damaging the compressor's canopy.
- Do not drop the compressor.
- Do not attempt to move the compressor by pushing or dragging it as this may cause jerky movements causing damage to the compressor.

NOTE

Removal of transit brackets:

Once you have placed the compressor in its final position, remove the red painted transit brackets and store for future use.

Locations:

- Bracket in between the base and airend support
- Bracket in between the base and motor
- Bracket in between the shroud and control panel box

5.1.4 Site requirements

- Install the air compressor in a clean, dry, cool and dust free room as extreme temperatures (hot or cold), moisture, and air borne contaminants can significantly affect compressor performance, durability and compressed air quality.
- Be aware the entrance to the compressor room should be high enough and wide enough to carry the compressor in and out.
- Leave a minimum of 1m (3.28ft) space around the compressor for safe and proper inspection, cleaning, and maintenance activities.
- Leave a minimum of 2m (6.56ft) space above the compressor for hot air to flow away from the compressor.
- Ensure the compressor is protected against direct sunlight and rain.
- Avoid exposing the compressor to excessive moisture (from rain, dryer vent etc.) as moisture can affect airend lubrication, promote rust formation on the compressor and lead to electrical problems of the motor.
- Neither install the machine in a location where flame is used or place any inflammable objects near the compressor.
- Ensure the room temperature is within 50°C (122°F) as high ambient temperatures can reduce oil life due to higher discharge oil temperature (DOT). It also results in high approach temperatures affecting cooling and condensation efficiency in the after-cooler and in air treatment equipment like air dryers.

- Ensure the hot and medium of other utility equipment like gensets/dryers/ boilers, etc., is not sucked by the compressor inlet or in any way the room temperature does not rise to prevent high discharge oil temperature.
- Ensure the ambient temperature does not drop below 0°C (32°F). Provide air supply openings and adjustable louvers to ensure that the minimum temperature does not drop down below 0°C (32°F).
- Install the compressor on a smooth, solid, level industrial concrete floor capable of bearing the weight of the compressor.
- Ensure unevenness of the surface is within 6mm (0.25")
- If the floor is splashed frequently with water while cleaning, then place your compressor on a raised concrete plinth 100 to 150 mm (4 to 6 inches) high.

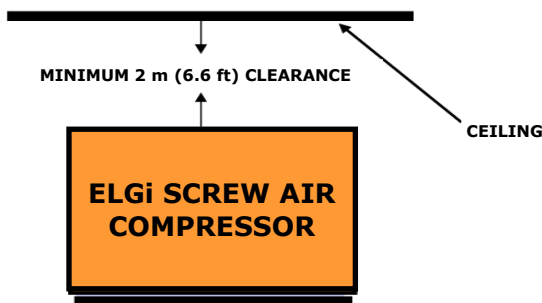

Figure 4. Vertical clearance around the compressor

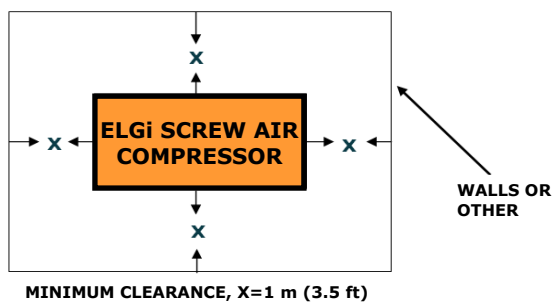

Figure 5. Horizontal clearance around the compressor

- Ensure the compressor base makes 100% contact directly with the floor.
- Know that an industrial floor with a level surface capable of supporting the weight if the compressor is sufficient for installing your compressor. No special foundation or anchoring is necessary for rotary screw compressors.
- Do not store toxic, volatile, or corrosive agents near the compressor.
- Isolate the compressor from corrosive agents like ammonia, chlorine, salt spray, and other chemicals as these may erode the internal components and also contaminate the oil and filters.
- Do not allow hot air from additional equipment to blow towards the compressor.

- If you operate in high dust applications like rice mills, cement, flour mills etc., clean and replace the filters more often.
- Good practice is to have overhead lifting in the compressor room to facilitate any major overhaul. If an overhead hoist is not available, you should be able to use a mobile crane or forklift truck in your compressor room at a minimum.

5.1.4.1 Ventilation

- A part of electric energy to your compressor motor is converted into heat and this heat must be removed from the compressor room by suitable ventilation.
- The ventilation requirements of the compressor are listed in Table 1.
- The ventilation requirements could be achieved by the following methods.
- Natural ventilation is sufficient if the temperature rise in the compressor room (measured by a thermometer near the air inlet pre-filter) is within 5°C (9°F) when compared with outside temperature.
- Forced ventilation with an exhaust fan is necessary if the temperature rise inside the room (measured by a thermometer near the air inlet pre-filter mesh) rises above 5°C (9°F) .
- Ventilation with ducts: Ensure hot air exhaust from the compressor is diverted through the ducts when installed in an enclosed area. (contact ELGi for ducting requirements)
- Provide openings on walls/partitions close to the air suction side of the compressor.
- Provide exhaust openings close to the ceiling for hot air exit.
- If more than four compressors are installed in a room, good practice is to ducting arrangements. This will avoid hot air recirculation.
- Be aware hot air recirculation in the enclosed area will affect the compressor performance.
- Ensure the air velocity in the supply and exhaust ducts does not exceed 4 m/s (13 ft/s).
- Know air velocity is ascertained during commissioning using an anemometer.

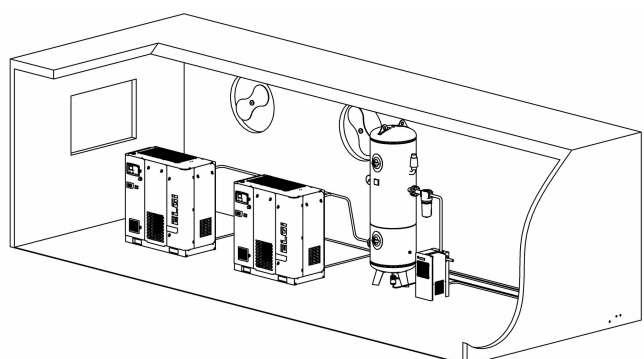

Figure 6. Forced ventilation with exhaust fan

- Do not connect cool air inlet ducts directly to the compressor inlet side.
- To eliminate transmission of vibrations, provide a soft bellows connector between the duct and the compressor.

- Contact ELGI in case you need to provide a duct connection or filter fitment on the compressor.

5.1.5 Electricals

⚠ WARNING

Ensure that only authorized service technicians carry out the electrical work. Study the electrical circuit diagram before starting the work.

1. Supply power to the compressor through a dedicated switch disconnected fuse (SDF) unit of suitable a rating mounted within 5 m (16.4ft) of the compressor. (This architecture lets you isolate the compressor).
2. Use an HRC (high rupturing current) fuse instead of an MCCB (moulded case circuit breaker) to avoid possible contactor and motor failure.
3. Refer to table 2 for fuse and cable specifications for 380/400/415 V, 50Hz,3-Ph power supplies.
4. Do not use an MCB (miniature circuit breaker) because the selection of contactors depends on Type-2 co-ordination.
5. Connect the earthing line to the point provided on the base frame at the side of the compressor and motor.

Model	Minimum ventilation requirement (ft ³ /h)	Minimum ventilation requirement (m ³ /h)
EG 11	94,537	2,677
EG 15	128,086	3,627
EG 18	157,185	4,451
EG 22	204,154	5,781
EG 30	242,576	6,869
EG 37	299,185	8,472
EG 45	363,847	10,303
EG 55	464,246	13,146
EG 75	631,708	17,888
EG 90	705,481	19,977
EG 110	864,821	24,489
EG 132	1,033,801	29,274
EG 160	1,273,482	36,061
EG 200	1,718,976	48, 676
EG 250	1,718,976	48, 676

Table 1. Global series – Ventilation requirements

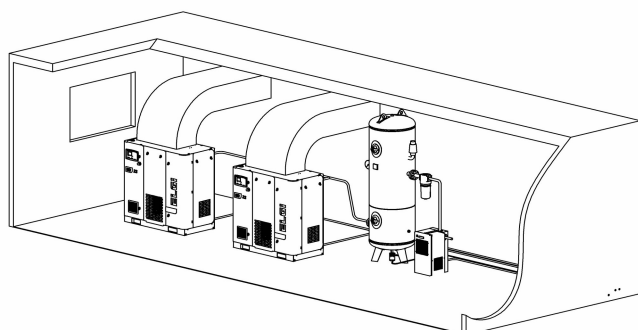

Figure 7. Ventilation with ducts

Compressor model	Incoming fuse rating	Incoming cable size (Armored) Copper	Incoming cable size (Armored) Aluminum	Earth cable size Copper	Power cable gland hole diameter
		Sq.mm	Sq.mm		
EG 11	32	4C x 6	4C x 6	2.5 Gauge	25 (0.984)
EG 15	50	4C x 6	4C x 10	4 Gauge	28 (1.102)
EG 18	50	4C x 10	4C x 16	4 Gauge	28 (1.102)
EG 22	63	4C x 10	4C x 25	4 Gauge	32 (1.259)
EG 30	80	4C x 25	3 ½ C x 35	6 Gauge	32 (1.259)
EG 37	125	3 ½ C x 35	3 ½ C x 50	6 Gauge	35 (1.377)
EG 45	160	3 ½ C x 50	3 ½ C x 70	8 Gauge	50 (1.968)
EG 55	200	3 ½ C x 95	3 ½ C x 120	12 Gauge	38.1 (1.50)
EG 75	220	3 ½ C x 95	3 ½ C x 120	25 x 3 flat	44.45 (1.75)
EG 90	220	3 ½ C x 120	3 ½ C x 150	30 x 3 flat	50.8 (2.00)
EG 110	250	3 ½ C x 120	3 ½ C x 150	35 x 3 flat	57.15 (2.25)
EG 132	315	3 ½ C x 150	3 ½ C x 185	50 x 6 flat	69.85 (2.75)
EG 160	400	3 ½ C x 185	2R x 3 ½ C x 240	50 x 6 flat	76.2 (3.00)
EG 200	500	2R x 3 ½ C x 185	2R x 3 ½ C x 240	50 x 6 flat	88.9 (3.50)
EG 250	630	2R x 3 ½ C x 240	2R x 3 ½ C x 300	50 x 6 flat	88.9 (3.50)

Table 2. Global series – Electrical requirements

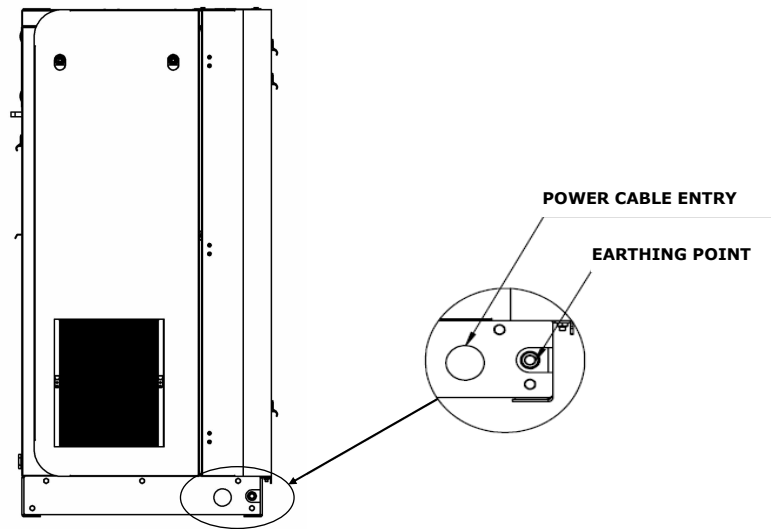

Figure 8. Earthing line of compressor

5.1.6 Air pipe dimensions

Volume Flow FAD		NPS Pipe size/ Inside diameter (mm)									
		1/2 15.80		3/4 20.93		1 26.65		1 1/4 35.05		1 1/2 40.89	
(m ³ /min)	(cfm)	(bar)	(psi)	(bar)	(psi)	(bar)	(psi)	(bar)	(psi)	(bar)	(psi)
0.1	4	0.02	0.22								
0.2	7	0.06	0.80	0.01	0.20						
0.3	11	0.12	1.69	0.03	0.41	0.01	0.12				
0.4	14	0.20	2.88	0.05	0.71	0.01	0.21				
0.5	18	0.30	4.35	0.07	1.07	0.01	0.32	0.01	0.08		
0.6	21	0.43	6.09	0.10	1.49	0.03	0.45	0.01	0.11		
0.7	25	0.57	8.10	0.14	1.99	0.04	0.59	0.01	0.15		
0.8	28	0.73	10.38	0.18	2.54	0.05	0.76	0.01	0.19	0.01	0.09
0.9	32	0.90	12.90	0.22	3.16	0.07	0.95	0.02	0.24	0.01	0.11
1.0	35	1.10	15.68	0.27	3.84	0.08	1.15	0.02	0.29	0.01	0.13
1.2	42			0.38	5.38	0.11	1.61	0.03	0.41	0.01	0.19
1.4	49			0.50	7.16	0.15	2.14	0.04	0.54	0.02	0.25
1.6	56			0.64	9.16	0.19	2.74	0.05	0.70	0.02	0.32
1.8	64			0.80	11.40	0.24	3.41	0.06	0.87	0.03	0.40
2.0	71			0.97	13.85	0.29	4.14	0.07	1.05	0.03	0.49
2.2	78			1.16	16.52	0.35	4.94	0.09	1.25	0.04	0.58
2.4	85			1.36	19.40	0.41	5.80	0.10	1.47	0.05	0.68
2.6	92					0.47	6.73	0.12	1.71	0.06	0.79
2.8	99					0.54	7.72	0.14	1.96	0.06	0.91
3.0	106					0.61	8.77	0.16	2.23	0.07	1.03
3.5	124					0.82	11.66	0.21	2.96	0.10	1.37
4.0	141					1.05	14.93	0.27	3.79	0.12	1.75
4.5	159					1.30	18.57	0.33	4.71	0.15	2.18
5.0	177							0.40	5.73	0.19	2.65
5.5	194							0.48	6.83	0.22	3.16
6.0	212							0.56	8.02	0.26	3.71
6.5	229							0.65	9.30	0.30	4.30
7.0	247							0.75	10.67	0.35	4.94
7.5	265							0.85	12.12	0.39	5.61
8.0	282							0.96	13.66	0.44	6.32
8.5	300							1.07	15.28	0.50	7.07
9.0	318							1.19	16.99	0.55	7.86
9.5	335							1.32	18.477	0.61	8.69
10.0	353							1.45	20.64	0.67	9.55
15.0	530									1.42	20.22

Volume Flow FAD		NPS Pipe size/ Inside diameter (mm)									
		1 1/2		2		2 1/2		3		4	
		40.89		52.50		62.71		77.93		102.26	
(m ³ /min)	(cfm)	(bar)	(psi)	(bar)	(psi)	(bar)	(psi)	(bar)	(psi)	(bar)	(psi)
0.8	28	0.01	0.09								
0.9	32	0.01	0.11								
1.0	35	0.01	0.13								
1.2	42	0.01	0.19								
1.4	49	0.02	0.25	0.01	0.07						
1.6	56	0.02	0.32	0.01	0.09						
1.8	64	0.03	0.40	0.01	0.11						
2.0	71	0.03	0.49	0.01	0.14						
2.2	78	0.04	0.58	0.01	0.17						
2.4	85	0.05	0.68	0.01	0.20	0.01	0.08				
2.6	92	0.06	0.79	0.02	0.23	0.01	0.09				
2.8	99	0.06	0.91	0.02	0.26	0.01	0.11				
3.0	106	0.07	1.03	0.02	0.30	0.01	0.12				
3.5	124	0.10	1.37	0.03	0.39	0.01	0.16				
4.0	141	0.12	1.75	0.04	0.50	0.01	0.21				
4.5	159	0.15	2.18	0.04	0.63	0.02	0.26	0.01	0.09		
5.0	177	0.19	2.65	0.05	0.76	0.02	0.31	0.01	0.11		
5.5	194	0.22	3.16	0.06	0.91	0.03	0.37	0.01	0.13		
6.0	212	0.26	3.71	0.07	1.06	0.03	0.44	0.01	0.15		
6.5	229	0.30	4.30	0.09	1.23	0.04	0.51	0.01	0.17		
7.0	247	0.35	4.94	0.10	1.42	0.04	0.58	0.01	0.20		
7.5	265	0.39	5.61	0.11	1.61	0.05	0.66	0.02	0.22		
8.0	282	0.44	6.32	0.13	1.81	0.05	0.75	0.02	0.25		
8.5	300	0.50	7.07	0.14	2.03	0.06	0.83	0.02	0.28	0.01	0.07
9.0	318	0.55	7.86	0.16	2.25	0.06	0.93	0.02	0.31	0.01	0.08
9.5	335	0.61	8.69	0.17	2.49	0.07	1.02	0.02	0.35	0.01	0.09
10.0	353	0.67	9.55	0.19	2.74	0.08	1.13	0.03	0.38	0.01	0.10
15.0	530	1.42	20.22	0.41	5.80	0.17	2.38	0.06	0.80	0.01	0.21
20.0	706			0.69	9.87	0.28	4.06	0.10	1.37	0.02	0.35
25.0	883			1.05	14.92	0.43	6.13	0.15	2.07	0.04	0.53
30.0	1059			1.46	20.90	0.60	8.59	0.20	2.90	0.05	0.75
35.0	1236					0.80	11.43	0.27	3.86	0.07	0.99
40.0	1412					1.03	14.63	0.35	4.94	0.09	1.27
45.0	1589					1.28	18.20	0.43	6.14	0.11	1.58
50.0	1765							0.52	7.46	0.13	1.92
55.0	1942							0.62	8.90	0.16	2.29
60.0	2118							0.73	10.46	0.19	2.69
65.0	2295							0.85	12.13	0.22	3.12
70.0	2471							0.97	13.91	0.25	3.57
75.0	2648							1.11	15.80	0.28	4.06
80.0	2824							1.25	17.81	0.32	4.58
85.0	3001							1.40	19.92	0.36	5.12
90.0	3177									0.40	5.69
95.0	3354									0.44	6.29
100.0	3530									0.48	6.92
150.0	5295									1.03	14.64

Table 3. Global series – Air pipeline dimensions

NOTE

The above table shows the pressure drops in 100m length schedule 40 steel pipe at 7 bar (abs)

1. Use the pipe sizes (as in Table 3) for the delivery pipe that connects to the ball valve of the compressor.
2. In case the main delivery pipe is more than 100 m (300 feet) long, use a pipe diameter that is one size bigger than shown in the table.

5.1.7 Receivers for compressed air systems

Receiver applications		Compressed capacity			
Volume		On/Off control		Modulation control	
m ³	ft ³	m ³ /min	cfm	m ³ /min	cfm
0.3	10.59	Up to 1.13	Up to 40	Up to 1.7	Up to 60
0.5	17.66	1.14 - 2.4	41 - 85	1.7 - 3.4	61-120
1	35.32	2.4 - 4.0	86 - 140	3.4 - 6.7	121-235
1.5	52.97	4.0 - 6.4	141 - 225	6.7 - 10.0	236-355
2	70.63	6.4 - 8.8	226 - 310	10.0 - 13.0	356-470
3	106.0	8.8 - 12.6	311 - 445	13.0 - 20.1	471-710
4	141.3	12.6 - 16.1	446 - 570	20.1 - 26.7	711-945
5	176.6	16.1 - 19.8	571 - 700	26.7 - 33.4	946-1180
6	211.9	19.8 - 24.0	701 - 850	33.4 - 40.0	1181-1415
7	247.2	24.0 - 28.0	851 - 990	40.0 - 46.7	1416-1650
8	282.5	28.0 - 32.0	990 - 1130	46.7 - 53.3	1651-1885

Table 4. Global series—Receivers specifications

5.1.8 Possible mistakes

1. The compressor is installed on the wooden pallet of the packing case.
2. The compressor base is not making 100% contact with the floor.
3. The compressor is mounted on anti-vibration mounts.
4. The isolator is more than 5m (16.40ft) away from the compressor.

5.1.9 Commissioning procedure

1. Please make preparations according to the installation section as given, before the compressor is commissioned.
2. Ensure that the location meets the requirements of accessibility, ventilation and safety.
3. Provide electrical power as recommended in the installation section.
4. Select air pipe lines and receivers for your system according to the tables provided in the installation section.

Checkpoints before commissioning

Replace the parts in compressor if it had been in storage for more than one year.

1. Air filter
2. Oil filter
3. Air oil separator (check and replace)
4. Oil
 - a. Check for any external / internal damages of the package.
 - b. Monger the main motor and fan motor should be mongered to find the winding insulation conditions if the compressor is not commissioned for more than 1 year
 - c. Re-grease the main motor to be carried out if the compressor is not commissioned for more than 1- ½ years (18 Months)

- d. Replace the AVMs if you detected any abnormal squeezing or damage in the rubber part.
- e. Check whether all the screws in the control panel are in place and tightened properly.
- f. Check the oil cooler and after-cooler for any external fin blockage and clear the blockage if necessary.
- g. Ensure that all the transit brackets are removed.

During commissioning

The Servicing technician performs a series of checks on the machine and on the systems to which it connects, to ensure that it is in a condition to function safely and as recommended. The Servicing technician will then explain how to operated and maintain the equipment. This procedure is referred to as the commissioning process.

The commissioning of the compressor ensures that it is installed safely.

The general operating conditions of the equipment including the cleanliness of the atmosphere, the temperature and the ventilation are checked. Technical details relating to your system such as particulars of your electrical installation are noted. The operator of the compressor is familiarized with all aspects of both its normal running and dealing with unusual situations.

Upon completion of the commissioning process, the technician will fill in the document known as the commissioning report and the warranty card provided in this manual.

During commissioning any modification suggested by the technician should be performed before the compressor is ready for regular use. Else, Warranty become void if not done. In case of change of operator other than the person trained, the new operator should be trained before he is dedicated for operating the compressor.

5.1.10 Oil fill procedure

Initial oil fill procedure

Check whether your compressor comes with the oil filled.

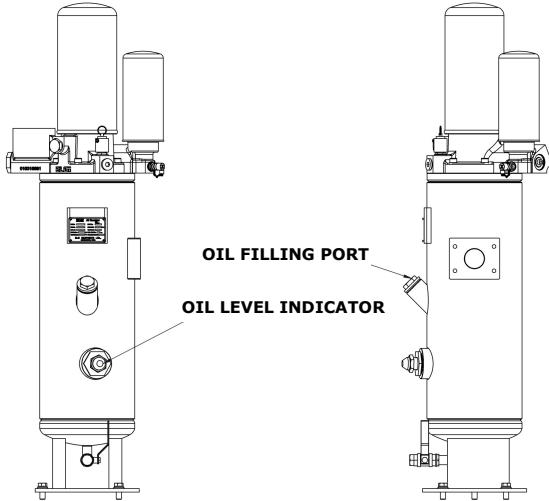
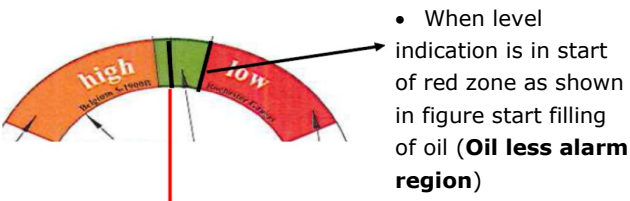

Figure 9. Oil filling and oil level indicator location on air oil separator tank

This can be checked through the oil sight float gauge on the air oil separator tank. If not, follow the oil filling procedure given below.

How to read oil level?



- Fill the oil up to this black line (black line in the green region) (**Oil Fill limit region**)

When to read oil level?

Following sequence to be followed before reading the oil level in separator tank

- Switch off the machine in load condition
- Wait for 3 mins to allow the oil drain back to separator tank
- Read the oil level as mentioned above

Oil level check

- The float gauge indication should be shown as "green" after fumes settle down after shutdown.

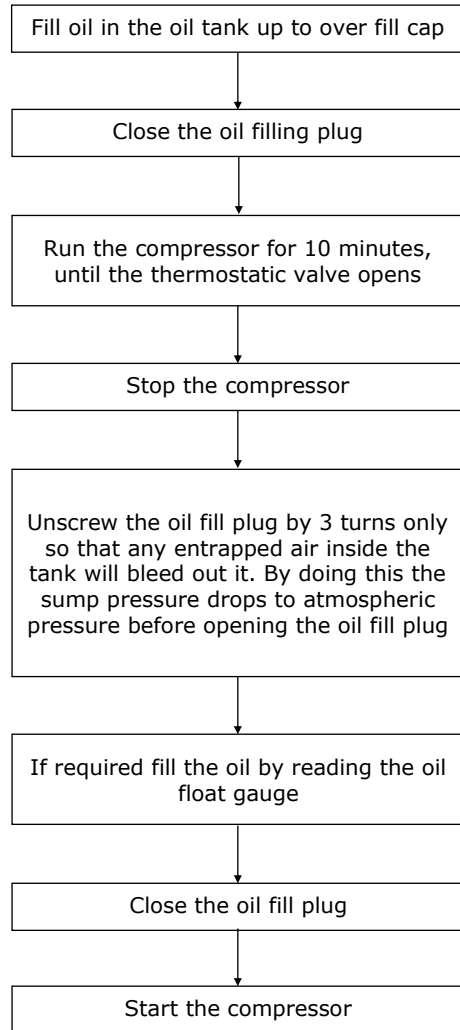

Sl. No.	Model	Volume of oil required (gal)
1	Airend 102	2.4
2	Airend 159 /159S	2.6

NOTE

Refill oil in the tank if the level falls below the minimum level.

5.2 Preservation for long idle storage

If your compressor is going to remain unused for six months or longer, special measures must be undertaken to ensure the protection of the following components:

- Airend
- Motors
- Air-oil separator tank
- Rubber hoses

5.2.1 Airend

To prepare the airend for 6-month storage:

- Remove the airend discharge hose/pipe coupling.
- Rotate the drive coupling three times so that the oil present inside the airend comes out through the discharge port.
- Block the discharge port completely.
- Remove the inlet rubber duct connected to the intake valve of the air filter assembly.
- Turn the intake valve flap and pour rust preventive oil (use Castrol DWX 32 or an equivalent grade) into the airend through the intake valve.
- Rotate the coupling five times by hand so that the rust preventive oil spreads all over the bearings, seals and other parts of the airend.
- Drain the rust-preventive oil by opening the discharge port plug fully.
- Refit the hose/pipe coupling on the discharge port.
- Take care to ensure that all the openings are plugged always to avoid dust entry.
- Rotate the compressor shaft once in 7 days and ensure free rotation.
- This procedure protects the airend for up to six months storage. It must be repeated every six months during storage.
- For more details contact ELGi office or ELGi's distributor network.

5.2.2 Motor

- To prepare the motor for 1-year storage: Check the insulation of the motor winding.
- Remove any moisture in the motor.
- Check junction box terminals for tightness of wires.
- Apply grease on the motor bearings.
- This procedure will protect the motor for up to one year storage.

5.2.3 Air-oil separator tank

To prepare the airend for 2-year storage:

- Drain the oil from the separator tank.

- Remove the entire tank from the compressor after disconnecting it from all hoses, the tank top plate, the minimum pressure valve outlet line, and control pulse lines and control switches.
- Clean the tank using ELGi compressor clean flushing oil.
- Check the air-oil separator tank.
- Replace the oil filter element before you use the compressor.
- Replace the air filter element similarly.
- Flush the tank, airend with compressor oil and replace the separator element before using the compressor again.

5.2.4 Rubber hoses

Test recommendations for rubber hoses	
Age	Recommendations
Up to 3 years	Use without further testing.
3 to 5 years	Use after representative samples are subjected to proof-pressure test.
5 to 8 years	Use after representative samples are subjected to proof, impulse, and burst pressure tests, and cold bend and electrical tests.
Over 8 years	Scrap.

5.3 Operating instructions

WARNING

Please adhere to the safety instructions provided at the section 2.3.2 : precautions during operations

5.3.1 Initial start-up checks

- Check whether the oil level in the tank is up to the specified level. If not, top up oil as per the oil fill procedure given in the maintenance section.
- Open all doors and visually check the compressor for abnormality. Make sure all connections are tight.
- Open the electrical panel door of the compressor and check that the three phases and earth cables are connected securely. (L1, L2, L3, and PE wires.)
- Check the necessary earthing line in the panel/ compressor base.
- Ensure that all condensate drains are connected properly.
- For water cooled compressors, ensure that the water inlet and outlet valves are opened. Also make sure that the inlet and outlet water drain valves are closed.

5.3.2 Initial start-up

Turn on power, open the air outlet ball valve and press the start button (Green). The direction of rotation of motor for gear driven airend is clockwise (C.W.) whereas in case of direct driven airend direction of rotation is counter clockwise (C.C.W.) from motor cowling side (non-driving side). The correct direction of rotation is also shown on the motor. Ensure correct direction of rotation. if not, stop the compressor by pressing the stop button (Red) on the control panel. Open the isolating switch and reverse the appropriate lines.

WARNING

Running the compressor in the wrong direction for more than 5 seconds will cause damage to compressor parts or even cause total damage.

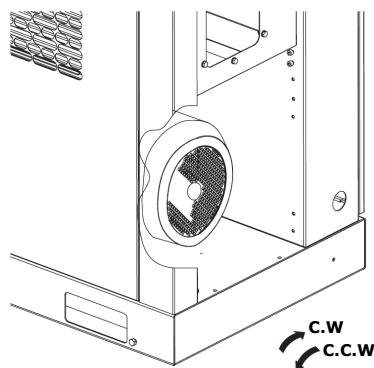

Gear models

- 11kW - All pressures
- 15kW - 10,13 bar
- 18.5kW - 13 bar
- 22kW - 13 bar

5.3.3 Daily start checks

Before using the compressor every day, you must prepare it by performing these tasks:

- Check whether the oil level in the tank is up to the specified level. If not, top up oil as per the oil fill procedure given in the maintenance section.
- Open all doors and visually check the compressor for abnormality. Make sure all connections are tight.
- Refer to section 6.1.1 for how to perform daily maintenance activities.

5.3.4 Starting

To prepare to start the system, perform these tasks:

- Turn on power.
- If all inputs from contact switches, pressure and temperature transducers are normal, the display will indicate "READY".
- Open the air discharge valve.
- Press the "START" (green) button on the controller.
- Machines with an automatic star-delta starter will have 6 seconds changeover time from star to delta and another 10-seconds delta-to-run delay.

5.3.5 During running

- To ensure seamless running:
- Monitor the controller display and control panel indicators regularly when the compressor is running.
- Graphic warning display: This gives graphically the location of fault.
- Discharge temperature sensor & warning: It is fixed on the air-oil discharge pipe. It senses the temperature of the discharge air-oil mixture. The compressor will shutdown automatically and the warning light on the controller will glow when the discharge temperature exceeds the preset value of $110 \pm 5^{\circ}\text{C}$ ($230 \pm 9^{\circ}\text{F}$).

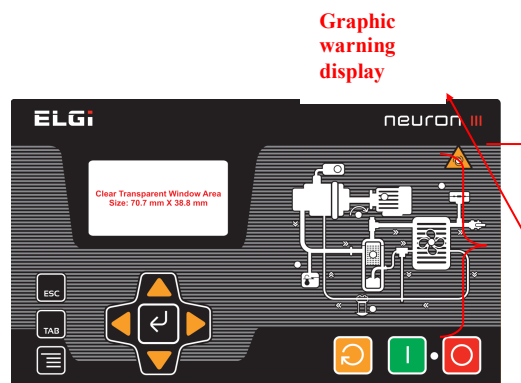

Figure 20 Human machine interface

- Separator element warning: Indicates that the separator element needs to be replaced. The

compressor will not shutdown automatically in this situation.

- Oil filter warning: Indicates that the oil filter element needs to be replaced. The compressor will not shutdown automatically in this situation.
- High discharge temperature warning: The compressor will shutdown automatically and the warning light on the controller will glow when discharge temperature exceeds the preset value of $110 \pm 5^{\circ}\text{C}$ ($230 \pm 9^{\circ}\text{F}$).
- Main motor overload trip: The compressor will shutdown when the main motor is overloaded and the corresponding warning light will glow.
- Fan motor overload trip: The fan motor has internal thermal overload protection, which safeguards the fan motor. If the fan motor trips, discharge oil temperature will be high and the compressor will trip.
- Reset button: This button must be pressed before restarting the compressor after it has shutdown with a warning. The machine must be restarted only after taking necessary remedial measures.
- Pressure relief valve: This valve relieves the pressure in the air-oil separator tank when it exceeds 14.5 bar. g (210 psi.g)
- Reverse direction switch: If the motor rotates in the wrong direction, the reverse direction switch detects and, in turn, trips off the compressor.
- After reaching the maximum cutoff pressure the pressure sensor senses the pressure and cuts off the solenoid electrical supply.

Model	Type	Cutout pressure bar
EG 11 - EG 45	Standard, Standard +VFD	Working pressure + 0.5
EG 55 - EG 75	Standard, Standard +VFD	Working pressure + 1
EG 90 - EG 160	Standard	Working pressure + 1
	Standard +VFD	Working pressure + 0.5

5.3.6 Stopping

- Press the stop (Red) button in the controller. The compressor will come to a halt within 10 seconds.
- In case of emergency, to stop the compressor use the emergency stop switch. Correct the fault, rotate counter clockwise, and unlock the emergency switch. Then press the reset button before the next start.
- Do not use the emergency stop switch for normal stopping.
- Close the air discharge valve.
- For water cooled models, close the water inlet valve.

- If any possibility of freezing exists, drain the cooling system completely.

WARNING

- *Isolate the power supply before the discharge ball valve closes.*
- *Do not use the emergency stop switch for normal stopping.*

5.3.7 Changing the compressor settings

Change the compressor settings using the tactile keypad and LCD panel on the controller. (Refer to Neuron manual to learn more about control panel and how interpret the message.)

Refer the VFD setting procedure manual for VFD operations.

Contents	Page No.
6.1. Maintenance	6.2
6.1.1 Maintenance intervals	6.2
6.1.2 Maintenance of individual components & systems	6.3
6.1.2.1 Pre filter	6.3
6.1.2.2 Air filter	6.3
6.1.2.3 Air oil Separator	6.4
6.1.2.4 Oil top up and oil changeover	6.4
6.1.2.5 Oil filter	6.6
6.1.2.6 Intake valve	6.6
6.1.2.7 Minimum pressure valve	6.9
6.1.2.8 Thermal valve	6.10
6.1.2.9 Electrical motor greasing	6.10
6.1.2.10 After and oil coolers	6.10
6.1.2.11 Cooler and motor suction prefilter	6.11
6.1.2.12 Drive coupling	6.11
6.1.2.13 Moisture separator and auto drain valve	6.12
6.1.2.14 Oil strainer	6.13
6.1.2.15 Anti Vibration Mount	6.13
6.1.3 Use only genuine spare parts	6.13
6.2. Troubleshooting	6.14
6.3. Decommissioning, dismantling & putting out of service	6.19
6.3.1 Waste disposal	6.19
6.3.2 Dismantling the compressor	6.19
6.3.3 Decommissioning the compressor	6.19
6.3.4 Disposal of consumables and replaced parts	6.19
6.4. ELGi services	6.20
6.4.1 ELGi customer care system (ECCS)	6.20
6.4.2 ELGi genuine spare parts	6.20
6.4.3 Air audit	6.20
6.5. Appendix	6.22
6.5.1 Conversion tables	6.22
6.5.2 Torque values	6.23
6.5.3 Service log book	6.24
6.6. Disclaimers	6.26

6.1.1 Maintenance intervals

Frequency	Part	Remarks
Daily	Oil level	Check
	MOS condensate	Check
	Warning / alarms	Check
	Condensate in AOS tank	Check
Weekly	Pre filter (air intake, cooler, control panel)	Clean
	Air filter element	Clean *
1000 hours or 3 months #	Pre filter	Clean
	Moisture drain	Clean
2000 hours or 6 months #	Oil & after coolers - air cooled (External)	Check & Clean
	Oil filter	Replace
	Oil	Sampling **
	50 Hz motor - 2 pole grease	Replace
4000 hours or every year #	Pre filter (air intake, control panel)	Replace
	Air filter element	Replace
	Oil – Air lube XD / Air lube FG	Replace
	Air-oil separator element – Air lube XD / Air lube FG	Replace
	50 Hz motor (4 pole) grease	Replace
	60 Hz motor (> 25HP) grease	Replace
	Return line sight glass / orifice / NRV	Check & Clean
	Return line strainer	Check & Clean
8000 hours or every 2 years #	Air-oil separator element - UT Synthetic	Replace
	Oil - UT Synthetic	Replace
	60 Hz motor (≤ 25HP) grease	Replace
	Electrical connections	Check
	Drive coupling element	Replace
	Pipe coupling element	Replace
	Intake valve kit	Replace
	Actuator kit	Replace
	MPV kit	Replace
	BDV kit	Replace
	Solenoid valve	Replace
	Safety valve	Replace
	MOS-ADV kit	Replace
	Thermal Valve Kit	Check & Replace
	Tubes and Fittings Kit	Replace
	Blow down adjustment kit	Check & Replace
Oil & after coolers - water cooled (External)	Check & Clean	

- Whichever comes first * - As per air filter clog indicator ** - For USA/CANADA region only

Table 5. Maintenance intervals

NOTE

The above life time guidelines are applicable only to standard operating and regular maintenance conditions recommended in this manual. In the event of changes in the conditions, consult

Precautions

A. If the compressor is kept idle

- Close the main air outlet valve.
- Drain the water from the condensate system.
- Close the inlet and outlet water valve. (applicable only for water cooled compressors)

B. If the compressor is kept idle for more than 6 months

- Follow the above steps.
- Refer to the section "Preservation for long idle storage".

Sl. No.	Motor make	Grease	Part Number
1	ELGi	EM UNIREX N3	015404151
2	SIEMENS		
3	WEG	EM POLYREX N2	015404152

Table 7. Electric motor grease

⚠ WARNING

Disconnect all the power at the source before you attempt to perform the maintenance or adjustment.

6.1.2 Maintenance of individual components and systems

Check all accessories independently to verify that they are functioning as required and replace their components as necessary.

6.1.2.1 Pre filter

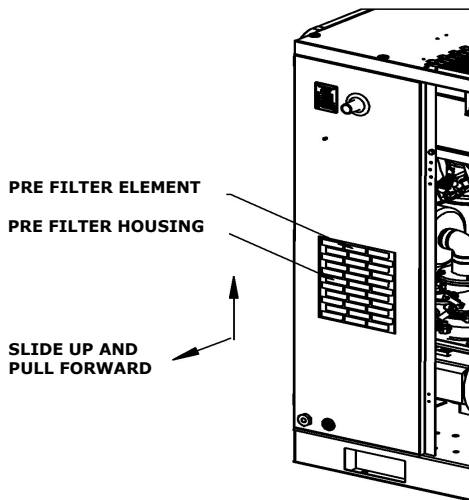

Fig 11. Pre filter

Pre work

- Switch off the compressor and disconnect power supply to the motor.
- Close the discharge end ball valve.
- Release the air oil tank pressure and allow the tank to cool for a few minutes.

Requirements

- Compressed air, new pre-filter element (if needed)

Maintenance

- Switch off the machine
- Refer to the pre-filter cartridge removal & insert procedure.
- Hold or fix the pre-filter assembly in the cleaning area.
- Clean the pre-filter with compressed air at less than 2.5 bar.g (36.3 psi.g) from the reverse or back side of the pre filter cartridge.
- In case of major dust/dirt accumulation in the pre-filter element, wash with clean water or light detergent.
- Do not use any acidic/alkaline chemicals for cleaning.
- Repeat this process based on dust conditions or at regular periodic intervals.

Suction pre-filter cartridge removal procedure

1. Slide Upward

Hold the pre-filter between the louvers and slide upwards slightly until the pre-filter bottom edge is visible

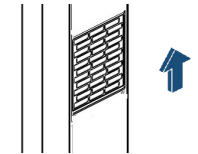

2. Slide Downward

When the pre-filter bottom edge is visible, slant the pre-filter forward and slide it downwards away from the compressor.

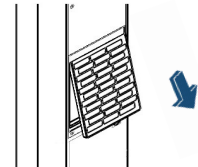

3. Pull Forward

When the top and bottom edges of the pre-filter are free from the main unit, move the pre-filter forward to remove completely.

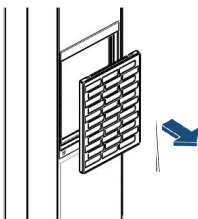

Suction pre filter cartridge insert procedure.

For insert sequence procedure from 3-2-1

6.1.2.2 Air filter

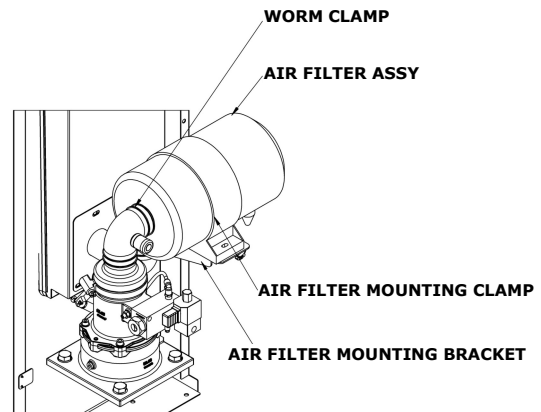

Figure 12. Air filter

If the air filter clog indicator shows a red color (meaning the blocked condition), then the air filter needs to be cleaned or replaced (if the stipulated life has elapsed).

Pre work

- Switch off the compressor and disconnect power supply to the motor.
- Close the discharge end ball valve.
- Release the air oil tank pressure and allow it to cool for few minutes.

Requirements

- Compressed air, new filter element (if needed).

Maintenance

- Unlock the mounting clips provided on the filter housing.
- Rotate and remove the filter element and remove it carefully.

- Clean from the filter using moisture free compressed air at less than 2.5 bar.g (36.3 psi.g).
- Clean from the inside to outside.
- Remove the dust ejector from the filter housing cap and clean it carefully.
- Show bright light from inner side of the filter element to inspect for damage or holes that result in leaks. Light will emerge from the holes, indicating their locations. In case of damages replace the filter element.
- Inspect all rubber seals and their contact surfaces of the housing. Faulty rubber sealing must be replaced immediately.
- Return the dust ejector back in correct (bottom) position.
- Return the filter element back in position, assemble the filter housing cap such that the dust ejector settles in bottom position, and lock the assembly using the mounting clips.
- Inspect and tighten all air inlet connections prior to resuming operation (if necessary).
- Reset the air filter clog indicator.
- If a clean element is to be stored for later use, it must be stored in a clean container.

6.1.2.3 Air oil separator

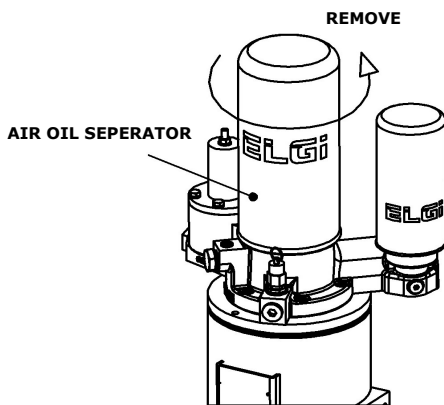

Figure 13. Air oil separator

Pre work

- Switch off the compressor and disconnect power supply to the motor.
- Close the discharge end ball valve.
- Release the air oil tank pressure and allow it to cool for few minutes.

Requirements

- Strap wrench, new separator element, clean cloth.

Maintenance

Disassembly of existing separator

- Hold the separator outer shell by the removed strap

wrench and rotate it counter clockwise, until it completely unscrews

- Ensure the hex adapter stays in the separator head during disassembly
- Once the recommended life is over, replace it with a new element.

Assembly of new Separator

- Ensure O-ring of the separator is damaged free.
- Clean the O-ring-seating surface with a clean cloth
- Apply a thin film of compressor oil on the mating surface of the O-ring.
- Return the separator to its original position and rotate it by hand clockwise.
- Ensure no oil leaks from the mating surface. In case of leakage, check the O-ring.
- After tightening by hand, rotate it further for one and a half times

NOTE

The air-oil separator tank is tested according to standards. Regularly have inspections performed in conformity with local regulations.

6.1.2.4 Oil top up & oil change over

Proper compressor maintenance and operation is crucial for the lubricant to function properly and last till its estimated rated oil hours. The oil product shelf life is of minimum 3 years and maximum 5 years. Products should be kept properly sealed in the original container. Once the seal is broken, the above stated life span of the product is no longer applicable. Products should be stored in proper storage warehouse that is away from direct sunlight and is not exposed to weather elements like rain, typhoon and snow storms. The products should also be stored away from any heat source, high humidity, and moisture areas. If drums are stacked on ground level, they should all be stacked horizontally with the bung openings arranged at the 3 and 9 o'clock position.

ELGi recommends that once the seal is broken, all products be used immediately. ELGi does not encourage reuse or recycling of any of these leftover fluids due to contamination hazard. ELGi will not warrant the quality of the product once the original seal is broken. Also ensure that the oils are not mixed up between brands and types.

Please refer Material Safety Data Sheet (MSDS) for oil spill handling and disposal procedures.

Pre work

- Switch off the compressor and disconnect the power supply to the motor.
- Close the discharge end ball valve.
- Release the air oil tank pressure and allow the tank cool for few minutes.

Requirements

- New oil, flushing fluid (if needed)

NOTE

- The compressor is filled with a particular oil, if you want to change over to other types of oil, perform steps 1, 2 and 3.
- If you want to change the oil but continue with the same kind (same brand & type) perform steps 1 and 3 only.
- Ensure that you drain at least 90% of oil capacity of the compressor; if not the residual oil can contaminate new oil.
- Ensure no oil spills on anti-vibration mount during maintenance.

Maintenance

Step 1: Draining

- Remove drain plug from the bottom of the separator tank and drain out all oil. Drain oil while the compressor is warm.
- Remove the pipe and drain plug from bottom of oil cooler. Then drain completely .
- Disconnect all oil pipe work to the prevent oil from being trapped. Then, drain completely.
- Drain oil from the airend discharge pipe after dismantling it.
- Drain oil from the airend by hand rotation.

Step 2: Flushing (Only for oil change over)

For flushing clean/non-varnished machines, using

Mineral/PAO oils

- Fill the compressor with the ELGi cleaner (use the same compressor oil fill volume) and run the compressor.
- After 500 hours of running, drain the cleaner.
- Send a sample** of the compressor oil to ELGi for oil analysis after 300 hours.

OR

- Fill the compressor with new compressor oil through the oil filling plug and run the machine as normal operation. New oil may not be able to run till its stated hours in this case, depending upon the conditions.
- Sample** the oil and send it to ELGi after 300 hours.

NOTE

- The cleaner is not recommended to run longer than 500 hours.
- Change the oil filter and oil separator after oil change over.

Polyglycols (PAG) and for varnished machines using mineral oils, PAO or PAG or Dieter

- Fill the compressor with ELGi cleaner (use the same compressor oil fill volume) and run the machine for no longer than 500 hours.

- After 300 hours, send a sample** to ELGi for analysis.
- It may take more than one charge of cleaner to properly clean the system.

** : Applicable only for USA/CANADA.

Step 3: Filling the oil

- Add fresh oil; fill it up to the oil fill plug. (initial fill)
- Close the oil fill plug
- Pour oil into airend through the intake valve after removing the air filter hose. Then restart the compressor.
- Allow it to run for about 10 minutes.
- Stop the compressor.
- Unscrew the oil filling plug after 5 minutes so that residual pressure in the tank is vented out through the bleed hole in the oil fill plug.
- Refill the tank up to the oil fill plug. (second fill)
- Restart the compressor.

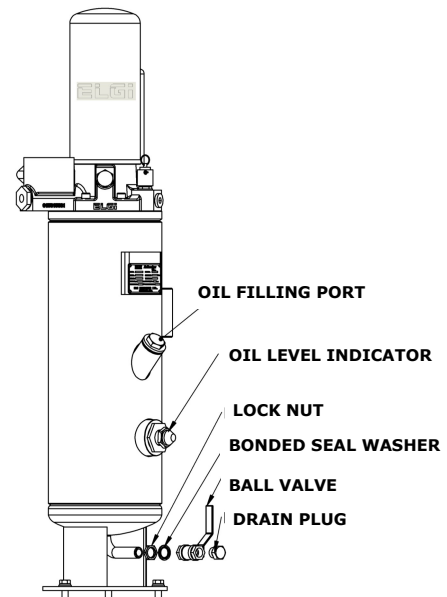

Figure 14. Air oil separator tank– oil drain

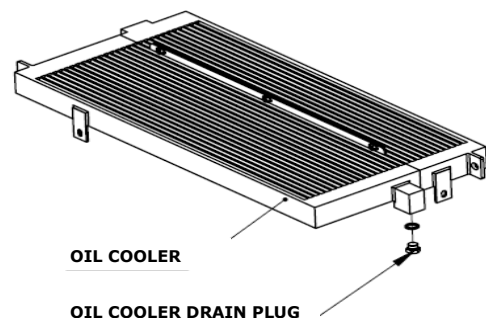

Figure 15. Cooler oil drain

6.1.2.5 Oil filter

The oil filter is fitted between the oil cooler and the air end unit. The components of the oil filter assembly are shown in the figure 15. This is a full flow filter with a pleated element. To service this filter, order the consumables kit (available with ELGi service personnel) The procedure for complete servicing of this filter is as follows.

Pre work

- Switch off the compressor and disconnect power supply to the motor.
- Close the discharge end ball valve.
- Release the air oil tank pressure and allow it to cool for a few minutes.

Requirements

- Strap wrench, new oil filter, and clean cloth, O-ring.

Maintenance

Disassembly of the existing oil filter :

- Isolate the machine from the service line, vent separator tank pressure, and allow the tank to cool for few minutes.
- Hold the filter shell and rotate it counter clockwise using the strap wrench.

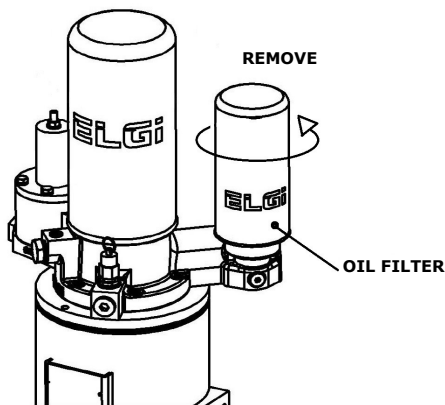

Figure 16. Oil filter

Assembly of new oil filter :

- Ensure the O-ring of the filter is damage free.
- Clean the seating surface with clean cotton
- Apply a thin film of compressor oil on the mating surface of the O-ring
- Return the filter to its original position and rotate it clockwise manually. After tightening, rotate it further by hand for one a half rotation
- Ensure no oil leaks from the mating surface.

NOTE

Suspended particulate matter should be less than 150spm to achieve the specified consumable life. Guarantee become void compressor is operated above its intended pressure.

6.1.2.6 Intake valve

WARNING

Valves should not be opened without releasing the pressure is applied.

NOTE

The maintenance of following parts (valves) demands highly skilled authorized personnel. So, it is recommended that an ELGi service engineer does the maintenance.

Pre work:

- Switch off the compressor and disconnect the power supply to compressor.
- Close the discharge end ball valve.
- Release the air pressure in separator tank and allow the tank to cool for 10 mins.

Requirements :

- Pressure gauge, Soft cloth, Grease, Liquid cleaner.
- Refer periodic maintenance kit
 - * **EIV 159:**Intake valve kit EIV 159, BDV Assembly kit EIV 159, Tamper Cap kit EIV 159 , Actuator Kit EIV 159, Hoses and Fittings Kit .
 - * **EIV 102:**Intake valve kit EIV 102, BDV Assembly kit EIV 102, Tamper Cap kit EIV 102 , Actuator Kit EIV 102,Hoses and Fittings Kit.

Disassembly procedure:

- Remove the connections of intake valve
 - * Pulse line & blow down line connection
 - * Power supply to solenoid
 - * Duct from air filter

NOTE

Below mentioned numbering procedure is documented for EIV 159. Same procedure to be followed for EIV 102. Ignore numberings that are unavailable in part list of EIV

- Remove the intake valve from Air end.
- Remove the Solenoid valve (26) & Hex nipple (37).
- Remove quick fittings (19),(49),(52) & hoses (36) (51A),(51 B).
- Remove the Silencer (50).
- Remove the BDV assembly from Top Housing(03).
- Remove O rings (27) & (45).
- Remove the Actuator block(34) from Bottom housing (01).
- Remove the Throttle plate (09) from Throttle shaft (08) by disassembling screw(11) and spring washer(10)
- Remove the Bush(8) and Sleeve (42) from top housing (03).

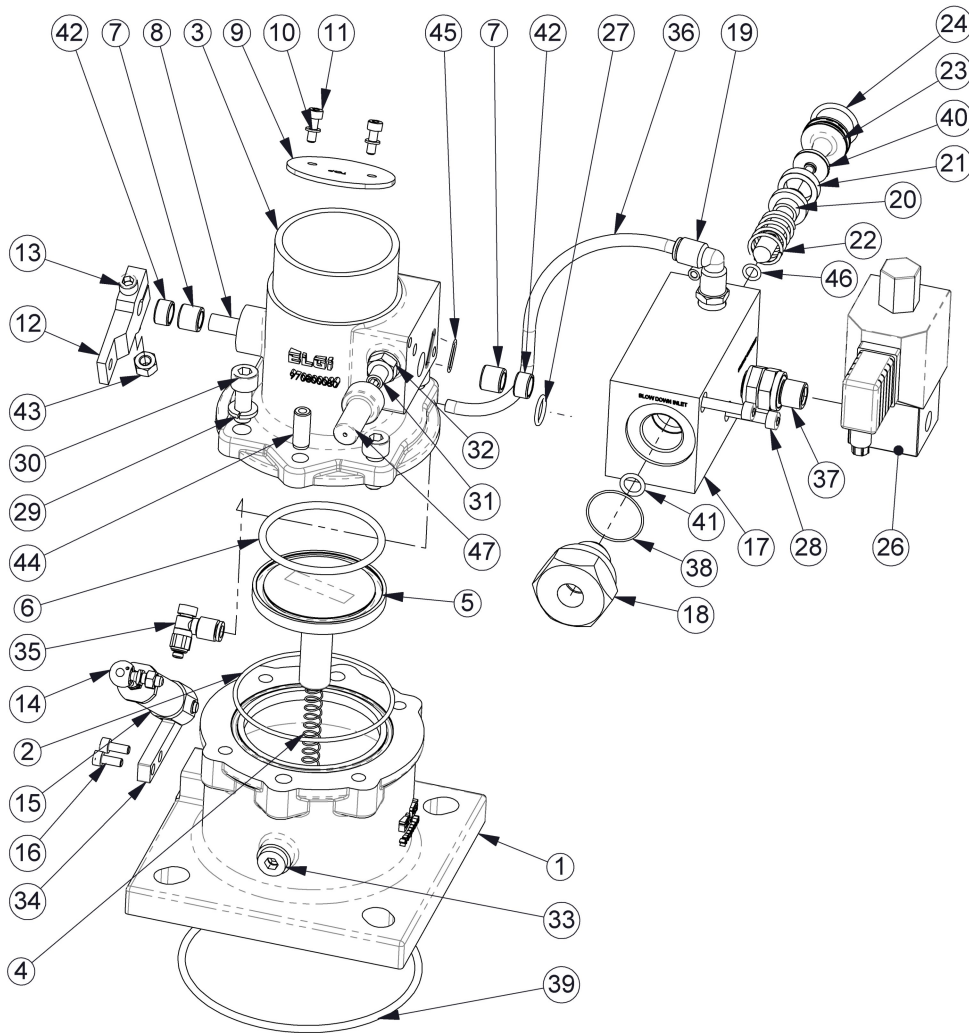

Figure 17. EIV 102 - 970300390-A970008

Sl. no	Description	Part number	Qty	Sl. no	Description	Part number	Qty
2	O-RING ID74.0 X 2.0	991401220	1	27	O-RING ID11.6 X 1.8	990402410	1
4	SPRING CHECK VALVE IV102	970400050	1	28	SCR SOC HD CAP M5x40	000983050	2
5	PLUNGER IV102	970300100	1	31	SCREW GRUB M8X40	970400370	1
6	O RING 54.02 X 3.53	970400220	1	32	NUT;HEX;M8; ZYP	000948008	1
7	BUSH THROTTLE SHAFT	970400030	2	34	SUPPORT ACTUATOR IV102	970400070	1
13	SCR SOC HD CAP M6x35	000983067	1	35	FLOW CONTROL VALVE	B013406760001	1
14	BALL JOINT MACHINED M5X0.8	B004900520003	1	36	TUBINGS 6MM	000920620	0.3
15	ACTUATOR PNEU.	B011406760001	1	39	O-RING ID110.7 X 3.5	415400814	1
16	SCR SOC HD CAP M5x16 12.9	000983044	2	42	SLEEVE 102	970400280	2
17	BLOWDOWN BLOCK	970300170	1	43	NUT NYLOC M6	000948307	1
19	QF ELBOW 1/4BSP-DIA 6	000920624	1	45	O RING ID 12.5X1	970400400	1
26	SOL VALVE NC,24V50/60HZ	B007300990017	1	47	TAMPER CAP EIV	970300680	1

Table 8. EIV 102 - 970300390

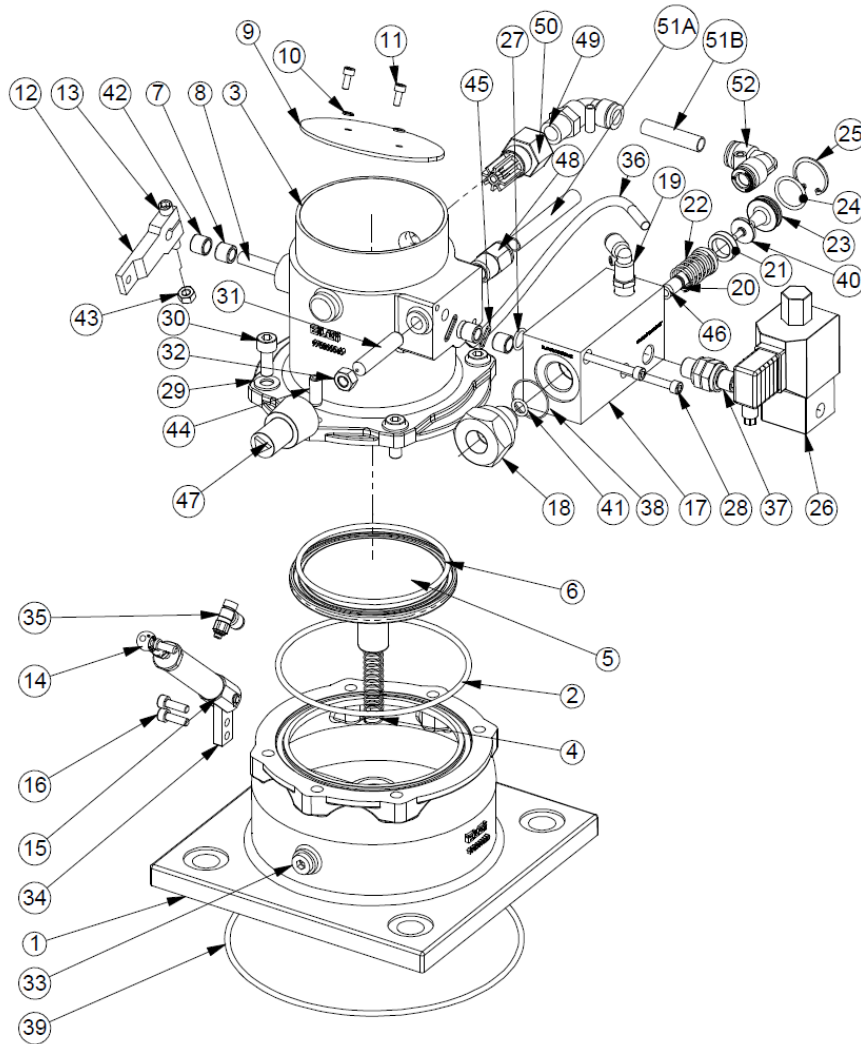

Figure 18. EIV 159 - 970300430 -A970012

Sl. no	Description	Part number	Qty	Sl. no	Description	Part number	Qty
2	O-RING ID122.0 X 3.6	415400655	1	32	NUT HEX M10 X 1 ZBP	000948013	1
4	SPRING CHECK VALVE IV159	970400040	1	34	SUPPORT ACTUATOR IV159	970400060	1
5	PLUNGER CHECK VALVE	970300690	1	35	FLOW CONTROL VALVE	B013406760001	1
6	O-RING ID94.8 X 3.5	220410750	1	36	TUBINGS 6MM	000920620	1
7	BUSH THROTTLE SHAFT	970400030	2	39	O RING 190 ID X 3.55	970400010	1
13	SCR SOC HD CAP M6x35 12.9	000983067	1	42	SLEEVE 159	970400270	2
14	BALL JOINT MACHINED M5X0.8	B004900520003	1	43	NUT NYLOC M6	000948307	1
15	ACTUATOR PNEU.	B011406760002	1	45	O RING ID 12.5X1	970400400	1
16	SCR SOC HD CAP M5x16 12.9	000983044	2	47	TAMPER CAP MPV	970300510	1
17	BLOWDOWN BLOCK	970300170	1	48	QUICK FITTINGS CONN	000920509	1
19	QF ELBOW 1/4BSP-DIA 6	000920624	1	49	QUICK FITTINGS ELBOW	000920609	1
26	SOLENOID VALVE NC,24V50/60HZ	B007300990017	1	50	SILENCER SLIT TYPE	970300750	1
27	O-RING ID11.6 X 1.8	990402410	1	51	NYLON TYBE 10x8MM BLUE	000919244	0.12
28	SCR SOC HD CAP M5x40 12.9	000983050	2	52	UNION ELBOW DIA 10	B010501880007	1
31	M10 HEX SOCKET GRUB SCREW	970400160	1				

Table 9. EIV 159 - 970300430-A970012

- Remove the Top Housing(03) from Bottom housing(01).
- Remove the Plunger(05) and Spring(04) from Bottom housing(01).

Maintenance

- Clean Bottom housing(01) bore dia, Plunger(5) sliding area with liquid cleaner.
- Clean the pivot hole of Top housing (03) in which throttle shaft rotates.

After cleaning replace all parts as per the kit drawing.

NOTE

Refer GA drawing (EIV 102 - 970300390& EIV 159 - 970300430,) for required torque values.

Assemble the intake valve in the following sequence:

- Insert the Spring(04) and Plunger(05) in the Bottom housing(01).
- Assemble the Top Housing(03) and Bottom housing (01).
- Insert the Bush(8) and Sleeve (42) in top housing (03).
- Assemble the Throttle plate (09) and Throttle shaft (08) with screw(11) and spring washer(10). Ensure the engraving "TOP" in throttle plate is facing the top side.
- Fasten the Actuator block(34) and corresponding actuator kit parts to Bottom housing(01) .
- Connect throttle shaft (08) and ball joint(14) with the help of shaft connector(12). Press the throttle plate against the housing (03) and fasten shaft connector(12) with bolt (13).
- Assemble O rings (27) & (45).
- Assemble the BDV assembly kit to Top Housing(03) with screw(28).
- Assemble quick fittings (19),(49),(52) & hoses (36) (51A),(51 B).
- Assemble the hex nipple(37) & Solenoid valve (26) .
- Assemble the intake valve on Air end.
- Connect the below mentioned parts to intake valve
 - * Pulse line & BDV tube connection
 - * Power supply to solenoid
 - * Duct from air filter

No Load sump pressure adjustment:

CAUTION

No Load sump pressure adjustment should be carried out by skilled ELGI service person only.

- Assemble the pressure gauge to the air oil separator tank by removing the plug.

- Start the compressor , run in unload mode and check no load sump pressure is in the range of 1.2 to 1.6 bar.g / 17.4 - 23.2 psi.g.
- If no load sump pressure is out of specification, follow the below steps to adjust the no load sump pressure.

Adjustment procedures as follows,

- Break & Remove the Tamper cap (47).
- Loosen Nut (32) .
- Adjust Blow down adjustment screw (31) to achieve no load sump pressure.
 - * Turn the screw clockwise to increase the no load sump pressure
 - * Turn the screw anticlockwise to decrease the no load sump pressure
- Fasten the Nut (32), after attainment of desired no load sump pressure
- Apply Loctite & Assemble the new tamper cap(47).

NOTE

After completion of intake valve assembly in package, ensure to verify the performance as per the product specifications. Also ensure that there is no leak in control system tubings and pipelines in the package.

6.1.2.7 Minimum pressure valve

Pre work

- Switch off the compressor and disconnect power supply to the motor.
- Close the discharge end ball valve.
- Release air oil tank pressure and allow the system to cool for a few minutes.
- Release the receiver tank and downstream pressure.

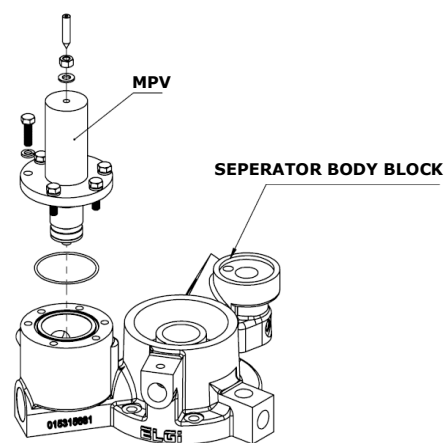

Figure 19. Minimum pressure valve

Requirements

- New MPV kit, allen key, grease.

⚠ WARNING

- Extreme caution should be taken while removing the cap or cover from the body because of the spring.
- Over and under setting of the MPV can upset machine performance

Maintenance

MPV Replacement

- Unscrew the four screws
- Remove and replace the old MPV kit with a new one.
- Grease the O-ring groove in the new MPV kit
- Assemble the MPV kit and reinstall the spring and cap.
- Tighten the bolts
- Adjust stud protrusion (6mm/0.236 inch) to achieve a minimum pressure of 4.5 bar.g (65 psi.g)

6.1.2.8 Thermal valve

Pre work

- Switch off the compressor and disconnect power supply to the motor.
- Close the discharge end ball valve.
- Release air oil tank pressure and allow the tank to cool for few minutes.

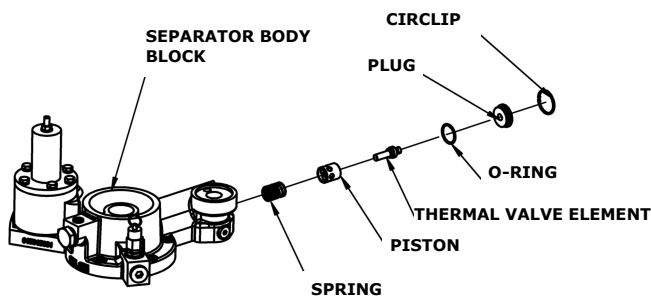

Figure 20. Thermal valve

Requirements

- Pliers, screw driver, new thermal valve element, new O-ring.

Procedure

Replacing thermal Valve

- Remove the circlip using a plier
- Remove the thermal valve from the separator body
- Inspect and clean seating area in the housing
- Fix a new thermal valve
- Assemble the valve in its place and lock it by circlips.
- Remove the plug using an M6 screw.

6.1.2.9 Electric motor greasing

Pre work

- Switch off the compressor and disconnect power supply to the motor.
- Close the discharge end ball valve.
- Release air oil tank pressure and allow the system to cool for a few minutes.

Requirements

- Recommended grease (refer table 7), cleaning cloth, grease gun.

Procedure

- Thoroughly clean the grease inlet fitting or plug. If the motor has a plug, remove the plug and clean the inlet.
- Remove the drain plug and wipe out any hardened grease.
- Slowly pump the grease into the grease inlet until the new grease comes out of the drain plug.
- Start the motor and let it run for a minimum of one hour to expel any excess grease from the drain opening before re-installing the drain plug.
- Stop the motor and lock out the switch.
- Re-install the drain plug.
- Put the motor back in operation.

6.1.2.10 After and oil coolers

Pre work

- Switch off the compressor and disconnect power supply to the motor.
- Close the discharge end ball valve.
- Release the air oil tank pressure and allow the system to cool for a few minutes.

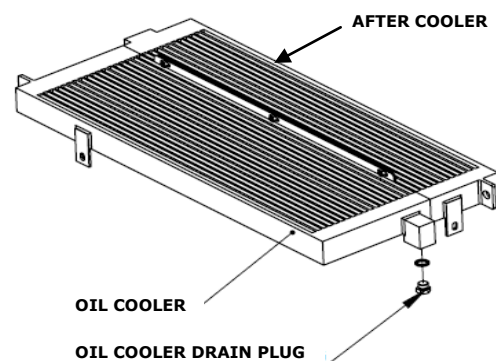
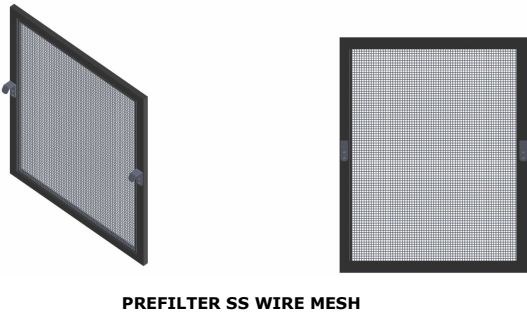
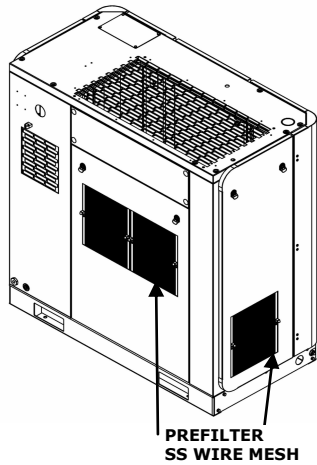

Figure 21. Cooler external surface

Requirements

- Pliers, allen keys.

PRE-FILTER ASSEMBLED CONDITION



PRE-FILTER DISMANTLED CONDITION

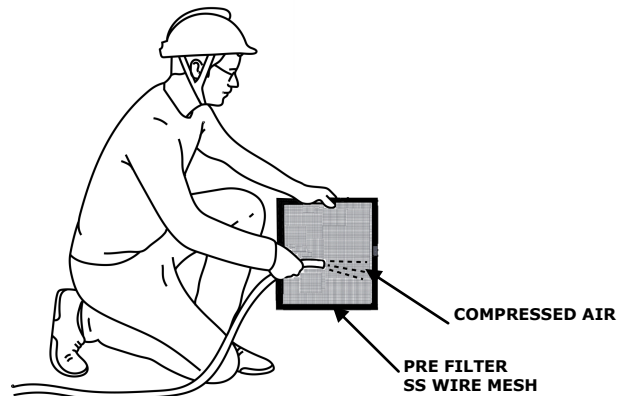
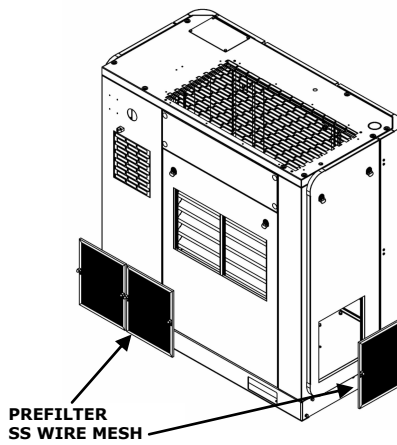

Figure 22. Pre filter –SS Wire-mesh

Maintenance

External surfaces

- Open both the LH panel and cooler inspection cover.
- Use compressed air below 2.5 bar.g(36.3 psi.g) to clean the outer surface of the cooler.
- Supply a jet of air in direction opposite to the cooling airflow direction
- After cleaning the outer surface of the cooler, properly close the cooler with a cleaning plate and an LH panel.

6.1.2.11 Cooler and motor suction prefilter

prefilter cleaning & maintenance instructions

- Lift upward & take out the cooler pre-filter assembly from the compressor.
- Hold the pre-filter assembly in the cleaning area.
- Clean the pre-filter with compressed air at less than 2.5 bar.g(36.3 psi.g) from the reverse / back side of the prefilter.
- In case of major dust / dirt accumulation in the pre-filter mesh, wash with clean water.
- Do not use any acidic / alkaline chemicals for cleaning.

- Repeat the process based on dust conditions or at regular periodic intervals.

6.1.2.12 Drive coupling

Malfunctioning of the coupling element results in abnormal sound and excessive vibration.

Pre work

- Switch off the compressor and disconnect power supply to the motor.
- Close the discharge end ball valve.
- Release the air oil tank pressure and allow the system to cool for few minutes

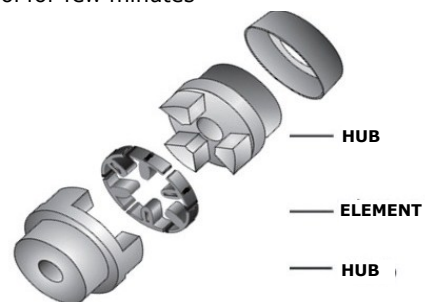

Figure 23. Drive coupling

Requirements

- Spanners, new coupling element.

Maintenance

Replacing the Coupling Element

- Open the cooler side panel covers
- Open the coupling guard from the adapter ring
- Remove the three coupling screws and slid the coupling element on the shaft spline to free the coupling element
- Replace the old coupling element with a new coupling element
- Tighten the coupling screws to the specified torque
- Assemble the coupling guard and cooler side panel cover
- Inspect every three month to ensure screw stay tight.

6.1.2.13 Moisture separator and auto drain valve



Moisture separator may be heavy. Caution should be taken while removing it from the machine.

Pre work

- Switch off the machine and disconnect power supply to the motor.
- Close the discharge end ball valve.
- Release the air oil tank pressure and allow the system to cool for a few minutes.

Requirements

- Spanner, screw driver, player, caustic soda.

Maintenance

Dismantling

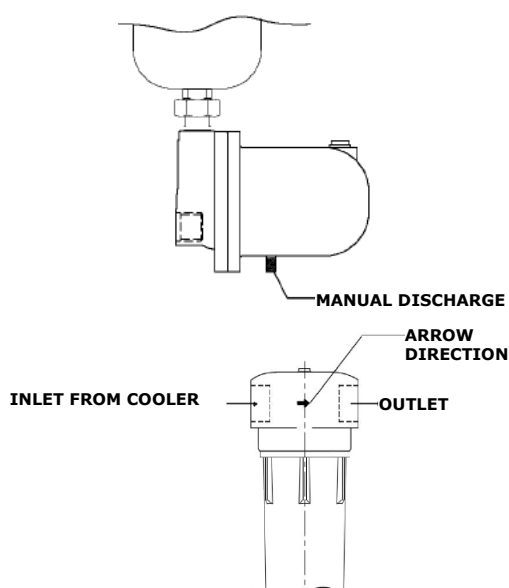

- Disconnect the pressure sensor line on top of the moisture separator
- Manually drain the condensate by using the manual discharge plug located at the bottom of the auto drain assembly.
- Remove the moisture separator from the machine
- Remove the bottom housing from the top housing.
- Remove the auto drain assembly from the bottom housing.

Cleaning and replacement

- Inspect the O-ring and replace it with new one in the kit, if necessary
- Clean the housing and all other inner parts
- Ensure the mating surfaces of the O-ring are clean and free from foreign particles
- The auto drain assembly is not serviceable and must be replaced with new one if not functioning

Reassembly

- The vortex generator cone and the cyclone arrestor need only to be tightened moderately by hand. Over-tightening may lead to failure or damage, ELGi assumes no responsibility for failure or damage resulting from such incorrect installation.
- Reassemble the auto drain assembly with the bottom housing and the bottom housing with the top housing.
- Reassemble the moisture separator in the machine and connect the pipe lines, pressure sensing line, and drain line
- Restart the machine and check for any leaks at the joints. If leaks occur, stop machine and wait for sump pressure to drop to atmospheric pressure.

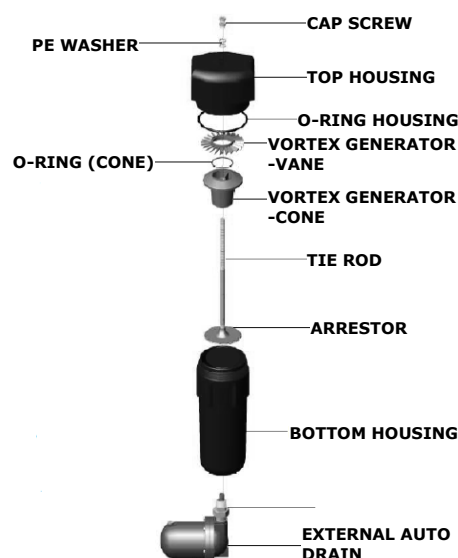

Figure 24. Moisture separator and auto drain valve

- Remove the O-ring as described above, and inspect and clean it
- Ensure that the mating surfaces are clean and refit the O-ring

6.1.2.14 Oil Strainer

Pre work

- Close the discharge end ball valve.
- Switch off the machine and disconnect the power supply to the motor.
- Release the air oil tank pressure and allow it to cool for few minutes.

NOTE

- *Avoid damaging the housing when removing or tightening the moisture separator. Do not use a pipe wrench. If necessary, use a locking strap clamp/wrench*
- *Install the separator in a vertical upright position, observing the correct direction of air*

Requirements

- Spanner / adjustable wrench

Maintenance

- Dismantle the plug strainer using the spanner.
- Remove the bonded seal washer from separator block body
- Take out the strainer mesh from the separator block body.

- Clean the filter using compressed air at less than 2.5 bar (36.3 psi). The direction of cleaning must be from outside to inside.
- Assemble the strainer in separator body block.
- Assemble the bonded seal washer to separator block body.
- Assemble the plug strainer and tighten.

6.1.2.15 Anti Vibration Mount

Anti Vibration Mount should be replaced during major overhaul of airend or motor. If no such situation, replace AVM every 5 years

6.1.3 Use genuine spare parts

It is very important to use genuine spare parts, to ensure that your compressor work as new for its lifetime. Spurious spares may seem less expensive initially, but they severely compromise on quality. Spurious parts will prove cost-ineffective in the long run, and may even result in total damage of the machine or cause serious accidents. The table includes certain critical spurious parts. It is not an exhaustive list, and you are strongly advised to avoid all other spurious spares that this table does not cover. Be aware of the consequences of using spurious spares including but not limited to the ones described in the table.

Effect	Spurious part	Remarks
Higher power consumption	Air oil separator	Due to dense filtration media, it creates in additional pressure drop and so causes additional power consumption. Every 1 bar (14.5 psi) of pressure drop results in ~7% additional power consumption.
	Lubricant	Spurious oil loses its properties soon and may get solidified causing the rotor to malfunction.
Reduced performance	Air oil separator	This imposes 10% additional resistance for air flow and creates more pressure drop and thus additional load on motor. Inadequate separation deteriorates air quality, reduce the performance, and damages downstream components. It also results in huge oil loss (1L / 200hr).
	Oil filter	Contaminants are not filtered properly and the contaminated oil affects the critical parts of airend. Thus it reduces performance and life (33% reduction) of the air end, air oil separator etc. Contaminated oil also cause clogging and reduces the cooler performance.
	Air filter	Dust carries over to the system and causes the same problems as caused by the spurious oil filter
Safety hazard	Air oil separator	Inadequate earthing can cause a separator to collapse (25% risk). Inadequate earthing can also cause fire and destroy the entire machine.
Cost		Higher power consumption means a higher operating cost. Reduced performance leads to extra functioning and operating cost. Spurious parts will damage the other components and accelerate maintenance frequency and cost. Higher consumption of consumables like oil (due to the use of spurious parts) will result in, increased cost.

6.2 Troubleshooting

This guide lists the most likely indications with possible causes. For any problem, follow the diagnosis in sequential order as mentioned in the following charts. Before doing any work in the compressor, be sure that electrical supply has been cut off and the entire compressor is depressurized.

Problem	Cause	Solution (go sequentially)
Compressor not starting	Power supply not available	Restore incoming power supply
	Incoming voltage is below limit	(1) Correct the incoming voltage.
		(2) Ensure isolator is within 5m (16 ft) from the compressor.
		(3) Ensure sufficient power back up
		(4) Select and use the correct cable size.
	Emergency stop switch in pushed condition	Rotate counterclockwise direction and release
	Emergency stop switch malfunction	Clean or replace the emergency switch.
		Tighten the wires at terminals
	Isolator fuse blown.	(1) Select correct fuse rating from selection chart.
		(2) Check and correct the short circuit within the control panel.
		(3) Dedicated isolator to be provided to the compressor.
		(4) Check and correct the motor winding/ body short after megger test.
	Incoming phase-to-phase voltage imbalance of more than 5V	Correct incoming voltage.
		Adjust main incoming transformer tapping.
		Correct the power factor to less than unity.
	Incoming phase to earth voltage imbalance of more than 5V	Correct the incoming voltage.
	Control MCB malfunction	Replace MCB
Control fuses inside compressor control panel blown	Check for any short circuit or loose connection.	
	Replace the solenoid valve / control transformer if defective.	
	Replace the glass fuse as per the drawing (for Neuron, for the control circuit).	
Control transformer fuse blown	Replace the control transformer if defective.	
	Replace glass fuse as per the drawing (for Neuron, for the control circuit).	
No power supply to Neuron controller.	(1) Replace control transformer fuses.	
	(2) Ensure tight connection of the 24V power supply connector to Neuron	
	(3) Replace control transformer.	
No display in Neuron controller	(1) Replace the control transformer.	
	(2) Replace the control fuse.	
	(3) If 24V power supply to Neuron is okay then replace with anew Neuron micro controller.	

Problem	Cause	Solution (go sequentially)
High discharge oil temperature	Oil level is low	(1) Check and refill oil to correct the level. (in stopped condition)
		(2) Refer diagnosis procedure for high oil carry over.
		(3) Arrest oil leaks
		(4) Ensure the correct grade of oil is used.
	Room temperature is higher than outside ambient temperature by 30°C (86°F)	Improve ventilation in compressor room
	Oil cooler clogged externally	Clean the cooler assembly / cooler pre filter mesh (if available) externally by first using a fibre brush and then blowing compressed air at 2.5 bar.g(36.3 psi.g).
		For sticky dust, remove the cooler, close all the cooler ports
		Install the cooler prefilter mesh.
	Cooling fan rotating in wrong direction.	Check and correct the wiring connection to the cooling fan.
		Replace with correct fan type.
	Check fan motor fuse	Replace the fuse if blown.
		Replace with the 2A fuse.
	Cooling fan not working.	Check and ensure the neutral connection is connected.
	Temperature sensor malfunction	Replace the sensor.
		Tighten/recrimp the connection with adaptor.
	Oil filter clogged	Replace oil filter.
		If required replace the oil (based on the condition of oil) and
	Thermal valve malfunctioning	Replace the thermal valve element.
	Oil injection orifice choked or improper size	Clean the oil injection orifice.
		Replace with correct size.
Air filter clogged	Clean or replace the air filter	
Separator element clogged	Check pressure drop is less than 1bar (14.5 psi).	
	Replace oil.	
	Replace separator element.	
Poor quality of oil	Replace oil.	
Oil cooler clogged internally	Check for pressure drop across the oil cooler if less than 1.5	
	Check and clean the cooler internally with 20L of isopropyl alcohol + toluene mixture in the 1:1 ratio and circulate for 4 hours with external 1 HP pump.	
	Refit the cleaned cooler and, if required, replace oil (based on	

Problem	Cause	Solution (go sequentially)	
High oil carry over	High oil level	Drain excess oil and maintain the recommended oil level.	
	Oil is milky	Replace oil and maintain the recommended level.	
	Scavenge return line non return valve (NRV)/ orifice clogged		1) Remove the return line NRV/orifice and clean it thoroughly.
			2) Change/clean the air filter.
	Scavenge return line tube clogged	Remove and clean the clogged scavenge return line tube.	
	Scavenge return line tube gap not maintained (not applicable EG11 to EG22)	Remove the return line tube from the separator and correct it.	
	The spin-on separator internal pipe thread damaged (applicable to EN series)	Replace the internal pipe.	
	High discharge oil temperature (DOT)	Refer to the diagnosis procedure for high DOT.	
	Improper grade of oil	Use ELGi recommended Air lube oil.	
	Separator punctured/collapsed (not applicable to EG11 to EG22 units)	Replace with new separator.	
	Separator element bonding ruptured (not applicable to EG11 to EG22 units)	Replace with new separator.	
	Compressor runs at lower pressure than normal pressure.		1) Use suitable higher capacity compressor or match demand to compressor capacity.
2) Arrest all line leakages.			
Minimum pressure valve (MPV) opening earlier than at the specified opening pressure* 4.5 bar.g (65.26psi.g). * 3.5 bar.g (50.8 psi.g) for compressors with working pressure 4.5 bar.g		Replace MPV kit/assembly.	
High tank pressure	Neuron microcontroller pressure settings: 1) Unload pressure set value is above specification. 2) High tank pressure set value is below	Check and correct the unload pressure and high tank pressure values in Neuron micro-controller	
	Intake valve malfunction	1) Check and replace intake valve kit if required.	
		2) Check the solenoid valve and clean or replace if required.	
		3) Check and replace the actuator kit if required.	
	BDV malfunction	Check/replace	
	Compressor started with air outlet ball valve closed	Open the outlet ball valve.	
	Solenoid valve malfunction	Check the solenoid valve and clean or replace if	
	Neuron microcontroller malfunction	Replace the Neuron microcontroller	
	Pressure transmitter malfunction	Replace the pressure transmitter	
MPV stuck up (check with pressure gauge in AOS tank)	Replace the MPV kit.		
Separator element choked	Replace the separator element		

Problem	Cause	Solution (go sequentially)
Loading/unloading Problem	No control air supply to solenoid valve	Replace / connect
	Solenoid valve malfunctioning	1. Replace the solenoid valve assembly
		2. Clean the orifice
	No electrical supply for energising the solenoid valve	Replace the Neuron microcontroller
	Intake valve malfunctioning	Check and replace the intake valve kit.
	Blow-down valve malfunctioning	1. Clean or change BDV assembly.
		2. Clean the orifice.
	MPV malfunctioning	1. Check and change the MPV kit.
		2. Check and change the MPV assembly
	Pressure regulator (applicable only to EG 55 to EG 250) setting lower than working pressure	1. Check and reset the pressure regulator setting to working pressure+0.3 bar (4.35 psi).
		2. Change the pressure regulator assembly.
	Actuator failure	Check and change the actuator / kit / assy.
	1. Air requirement is more than compressor capacity	1. Replace the compressor 2. Arrest all pipeline leakages.
	2. Working pressure is lower than required application pressure.	
	3. Excess pressure drop in pipe line.	
Pressure transmitter malfunction	1. Tighten the lap cable	
	2. Replace the lap cable	
	3. Replace the pressure transmitter	
	4. Replace the Neuron microcontroller	
Malfunction of R04 relay (loading/ unloading relay) in Neuron microcontroller	Replace the Neuron microcontroller	
Unload mode enabled in Neuron microcontroller	Disable 'unload mode' in operator settings of the Neuron microcontroller	

Problem	Cause	Solution (go sequentially)
Pressure not built up	Inlet air pre-filter mat clogged	Clean/change pre-filter mat by following these steps: Switch off the machine. Squeeze and pull out the pre-filter mat from the canopy. Clean pre-filter with compressed air at less than 2.5 bar /36.3 psi Refit the filter after cleaning.
	Clogged air filter element	Clean/change air filter element.
	1. Air requirement is more than compressor capacity	1. Replace compressor 2. Arrest all pipeline leakages.
	2. Working pressure is lower than required application pressure.	
	3. Excess pressure drop in pipe line.	
	No control air supply to solenoid valve.	Replace / connect the control line tubes.
	Solenoid valve malfunctioning	1. Replace the solenoid valve assembly
		2. Clean the orifice
	No electrical control supply to solenoid valve	Replace the microcontroller
	Intake valve malfunctioning	Check and replace intake valve kit.
	Blow down valve malfunctioning	1. Check and change the BDV assembly.
		2. Clean the orifice.
	MPV malfunctioning	1. Check and change the MPV kit.
		2. Check and change the MPV assembly
Pressure regulator (applicable only to EG 55 to EG 250) setting lower than working pressure	1. Check and reset pressure regulator setting to working pressure+0.3bar (4.35 psi).	
	2. Change pressure regulator assembly.	
Actuator failure	Check/change actuator / kit / assembly.	
Separator element choked (increase in pressure drop across separator)	Replace separator element. If required, replace the oil (based on condition of the oil) and run the compressor.	

If you do not intend to use the compressor or any of its parts, you must dismantle and putting out of service. These tasks must be carried out in compliance with the standards in force of that particular country.

6.3.1 Waste disposal

- Use of compressor generates waste. The residues from agricultural, industrial, crafts, commercial and service activities must be treated as waste, which needs to be disposed off properly. Deteriorated or obsolete machines are also classified as waste.
- Special attention must be given to active carbon filters as they cannot be included in urban waste. Observe the waste disposal laws in force where the compressor is used.
- It is mandatory to record loading or unloading of exhausted oils, obsolete machines and toxic harmful wastes that derive from heavy or light industry processes.
- It is especially important that exhausted oils be disposed off in compliance with the laws in the countries of use.

6.3.2 Dismantling the compressor

- Dismantle the compressor in accordance with all the precautions imposed by the laws in force in the country of use.
- Before dismantling, request an inspection by the relevant authorities. Disconnect the compressor from the electrical system.
- Eliminate any interfaces the compressor may have with other machines, making sure that interfaces between remaining machines are unaffected.
- Empty the air oil tank containing the lubricating oil and store in compliance with the laws in force.
- Proceed with the disassembly of the individual compressor components and group them together according to the materials they are made of: Steel, Stainless Steel, Aluminium and plastic parts.
- Then scrap the machine in compliance with the laws in force of the country of use.

6.3.3 Decommissioning the compressor

- Remove the foundation for the compressor.
- Unplug the power cable entry to the compressor.
- Drain the oil from the cooler and air oil tank. Dispose of it properly.
- Make sure all the compressed air is vented out through ball valves and safety devices residing in the compressor.
- Ensure that all the external supply lines have been properly disconnected from the compressor before decommissioning.

6.3.4 Disposal of consumables and replaced parts

- The moisture condensate separated from the compressed air contains oil particles. Disposal of condensate and filter element is to be done in accordance with the pollution control norms prevailing at the time of compressor installation or use.
- Parts of the compressor that are replaced have metal and rubber components. These may be recycled and disposed of according to pollution control regulations, respectively.
- Rubber items such as AVMs, coupling elements, and O-rings should be disposed and replaced before running again.

NOTE

ELGi is not responsible for the disposal of old oil or condensate. It is the responsibility of customer to dispose of the foregoing in accordance with local environmental statutory laws.

WARNING

The compressor does not give any warnings during short operating times. If it is operated below the dew point and moisture condensate may mix with oil. This will reduce the lubricating quality of the oil and lead to damage of compressor.



6.4.1 ELGi customer care system (ELGi CCS)

ELGi provides dedicated customer care and after-sales support through the ELGi customer care system (CCS), a computerized system developed in-house. The CCS aims to minimize the time taken to resolve customer complaints.

Service requests/complaints

The CCS toll-free telephone number 1800-425-3544 (accessible within India through BSNL and MTNL lines) patches the customer's call to our centralized customer care center in Coimbatore. Customers can register their service requirements or complaints here.

A unique tracking number is generated for each call logged by the CCS. The customer receives an automatic e-mail acknowledgement with the tracking number and details of the call for reference.

A service engineer is assigned to the call, and the date and time of the engineer's visit are communicated to the customer by e-mail. Every requirement or complaint must be resolved and closed in the CCS within a specified time limit, failing which the complaint is automatically brought to the notice of the manager. If the issue remains unresolved, it will get escalated to the managing director. The CCS ensures that not only the customer complaints are logged but they are also attended to on time, every time.

Enquiries

A number of calls received by the CCS relate to customer queries regarding products and spare parts. The details are noted, and basic information on product specifications and usage is provided. The caller is then referred to a salesperson at the head office or the appropriate branch for follow-up.

The CCS database

The CCS also creates a database of customers, adding details of every new customer who calls, thereby building a large pool of installation details. These details are used to provide value-added services to improve customer satisfaction with ELGi products.

CCS-working hours

The ELGi CCS works for six days a week from 08:30 to 21:30 IST (Monday to Saturday).

Multi-lingual capability

The coordinators at the CCS are multi-lingual. They can handle calls in English and all the major regional languages of India.

Coverage: The CCS toll-free number 1800-425-3544 is accessible from the following areas:

- **Southern Region:** Tamil Nadu, Karnataka, Kerala, Puducherry, Andhra Pradesh, Telangana, Andaman & Nicobar Islands.
- **Western Region:** Maharashtra, Gujarat, Madhya Pradesh, Goa, Lakshadweep Islands.
- **Eastern Region:** Orissa, Chhattisgarh, Jharkhand, West Bengal, Bihar and the North-Eastern states.
- **Northern Region:** Rajasthan, Uttar Pradesh, Delhi, Haryana, Punjab, Uttaranchal, Himachal and Jammu & Kashmir.

Contact Numbers: You can contact CCS also with the following numbers:

Telephone: 0422-2589206 / 241 / 242 / 243/ 244 / 245 / 97900 21100

Fax: 0422-2589240

Please send the following details to the mail, thus enable us to take immediate action.

1. Name of the customer
2. Compressor model
3. Fab. number
4. Contact person name
5. Phone number
6. Nature of complaint
7. Hour meter reading

You may use the CCS by sending e-mail to: **ccs@elgi.com**

Customer satisfaction survey

If you have used the CCS, you may be contacted for your feedback on our after-sales support. Your response helps ELGi to improve.

International customers:

Refer contact information at the end of this manual book.

6.4.2 ELGi genuine spare parts

When ordering spare parts, refer to the lists provided in the parts manual and identify the part number. Specify the part number and quantity, in addition to the name plate details. Global support center of ELGi ensures the supply of the quality spares on time. Ensure that you are using the genuine spare parts so that your Compressor will be working efficiently and effectively. Refer to section 6.1.3 for details on need of using genuine spares.

Please contact our After sales team for any compressor accessory requirements like VFD, Air-Dryer, etc.

6.4.3 Air audit

We extend our proven capabilities in energy efficiency initiatives by carrying out air audits for our customers.

ELGi conducts audits and trains end users in key energy oriented functional areas. The audit reports prepared by ELGi experts' team include recommendations on short,

medium and long term measures for energy conservation, along with financial estimates and analysis for implementation.

This air audit objective is to provide the customer with :

- The framework for systematic collection of data relevant to the efficient operation of compressed air systems.
- A thorough analysis about the performance of the compressed air system, identifying potential electricity savings and to provide sound recommendations for implementation of energy efficiency initiatives.

Data analysis will be comprised of the information about different areas such as air leakages, inappropriate use of compressed air, compressed air system network, compressed air system supply including compressor internal maintenance conditions and even more.

The final report issued to the customer end will serve the purpose of assisting concise, consistent and complete presentation of the analysis, findings and recommendations arising from a compressed air system audit.

Depending on the measurement, reporting and cost requirements from the customer end, the intensity in level of audit (base level or investment level) will be decided. Also post implementation monitoring after air audit will be provided if requested from the customer end.

For further information on air audit contact ELGi.

E-Mail: ccs@elgi.com



6.5.1 Conversion tables

Description	From	To	Multiply by
Length (L)	Inches	Millimetres	25.4
	Metres	Inches	39.37
	Feet	Millimetres	304.8
	Metres	Feet	3.281
	Inches	Thou	1000
	Millimetres	Micrometres	1000
Area (A)	Square metres	Square feet	10.765
	Square feet	Square inches	144
	Square inches	Square millimetres	645.16
Volume (V)	Cubic metres	Cubic feet	35.315
	Cubic feet	Cubic inches	1728
	Cubic metres	Litres	1000
	Cubic feet	Litres	28.32
	US gallons (liq)	Litres	3.785
	Imperial gallons (liq)	Litres	4.546
Volumetric flow (Q)	Cubic feet per minute (cfm)	Cubic metres per hour (m ³ /h)	1.6988
	Cubic feet per minute (cfm)	lpm	28.32
	Cubic metres per hour (m ³ /h)	lpm	16.667
	Cubic metres per minute (m ³ /min)	lps	16.667
Mass (M)	Kilograms	Pounds	2.205
	Kilograms	Grams	1000
	Kilograms	Ounces	35.27
Pressure (P)	kg f/cm ² g	psi g	14.223
	psi g	Pascal	6895
	bar g	kg f/cm ² g	1.0197
	bar g	psi g	14.503
	psi g	kg f/cm ² g	0.0703
Temperature (T)	Degree Celsius (°C)	Degree Fahrenheit (°F)	°F = 9(°C)/5 + 32
	Degree Celsius (°C)	Kelvin (K)	K = °C + 273.15
	Degree Fahrenheit (°F)	Degree Rankine (°R)	°R = °F + 460
Heat (q), Work (W), Energy (E)	ft-lb f	Joules	1.35582
	ft-lb f	Btu	0.001285
	Joules	Calories	0.2388
	Btu/h	Calories/h	252
	Kilowatts	Btu/h	3411
Power (P)	Metric horsepower	Kilowatts	0.7355
	Imperial horsepower	Kilowatts	0.7457

Table 8: Conversion table

6.5.2 Torque values

The tightening torque values for bolts and screws used in ELGi Compressors are provided in this section for reference. The tolerance for the torque values is (-) 10% from the given value.

Thread size*	Tightening torque (N-m)	Tightening torque (lb-ft)
M4	2.9	2.13
M5	5.7	4.20
M6	9.8	7.22
M8	24	17.7
M10	47	34.66
M12	81	59.73
M16	197	145.28
M20	385	283.93

Table 9: Metric hexagonal head bolts and screws

Thread size (inches)	Tightening torque (N-m)	Tightening torque (lb-ft)
1/4"	45	33.19
1/2"	85	62.69
3/4"	170	125.38
1"	330	243.39
1 1/4"	430	317.15
1 1/2"	510	376.15

Table 10: BSP threads

Thread size (inches)	Tightening torque (N-m)	Tightening torque (lb-ft)
9/16"	149	109.8875
7/8"	579	427.0125

Table 11: UNF threads

* Property class of 8.8 only

Please read this document and the warranty terms accompanying the product carefully before using our product. By purchasing our product, you agree that you will assume total responsibility and risk for your use of the product. The warranty terms of the product have been provided separately.

1. ELGi is not liable for failure of the compressor (hereinafter "compressor" or "product") to perform its obligations if such failure is as a result of Acts of God (including but not limited to fire, flood, earthquake, storm, hurricane or other natural disaster), war, invasion, act of foreign enemies, hostilities (regardless of whether war is declared), civil war, rebellion, revolution, insurrection, military or usurped power or confiscation, terrorist activities, nationalization, government sanction, blockage, embargo, labour dispute, strike, lockout or interruption or failure of electricity or telephone service and any other reasons beyond ELGi's control.
2. ELGi does not take responsibility for any damage or injury resulting from neglecting the safety instructions, warnings, cautions, precautions, or non-observance of the normal caution and care required for installation, operation, maintenance and repair of the product, even if not expressly stated, and such instances are specifically disclaimed by ELGi.
3. The entire literature including product description or any other information in this manual exclusively belongs to ELGi and is subject to copyright. No person has any right to copy, modify, distribute, transmit, display, perform, reproduce, publish, license, create derivative works, transfer or sell any information, or deal with the same in any other manner, without the knowledge and written concurrence of ELGi, violation of which would amount to infringement of rights of ELGi and would necessitate legal action.
4. The information published in this manual may include inaccuracies, or typographical errors. Changes may be periodically added to the information herein. Any changes/improvements may also be made to the products stated in this manual and ELGi is not liable if the readers are not updated with information.
5. Likewise ELGi is responsible only till the point of first sale to the ultimate customer and not thereafter and only if the product is purchased from authorized dealers of ELGi. ELGi disowns liability on account of purchase of any second hand product or purchase otherwise from unauthorized dealers. ELGi shall not be liable for any indirect, incidental, punitive, special or consequential losses or damages including any loss of profit, loss of production, loss of income or contract, loss of goodwill, expected savings or business relationships, arising out of or in any way connected with the usage of the product or information in this manual.
6. In no event ELGi shall be liable for any claims or loss having a value higher than the original purchase price of the product sold by ELGi or its network of authorised dealers.
7. These Disclaimers and the contents of this manual shall be subject to the laws of India and any disputes pertaining to this manual or anything stated therein or any product stated therein is subject to the exclusive jurisdiction of the courts in Coimbatore, Tamil Nadu, India.
8. No liability in connection with the product will accrue to ELGi,
 - If any welding or related operation involving heat is carried out in the compressor. Never weld or modify any parts including pressure vessels.
 - If any damages to the product directly or indirectly arise due to long storage (6 months) of product and subsequent corrosion of internal parts and which leads to fire or malfunctioning of the product.
 - If the compressor package and its accessories are installed in such a way to allow moisture, rain, freezing temperature or sun damage to affect the safe operation of the unit.
 - If the person who operates / maintains the compressor does not adhere to all work related safety practices and regulatory requirements.
 - If unauthorized personnel other than ELGi authorized or trained personnel carries out commissioning, installation, operation, maintenance and any repair work on the compressor.
 - If the compressor and the compressed air are used for unintended use or are misused.
 - If the compressor is operated below or in excess of its pressure and temperature limits.
 - If the compressor "ON/ OFF" switch is operated through remote control situated away from the compressor location without giving any adequate notice / alarm before starting the product .

© Copyright ELGi Equipments Limited, India 2018. All Rights Reserved.





Controller Manual

Neuron III

Version 3.6
July 2020

Contents	Page No.
Abbreviations used	7.4
7.1. Technical specification	7.5
7.2. Installation instruction	7.7
7.2.1 Equipment's safety	7.7
7.2.1.1 Static discharge warning	7.7
7.2.1.2 Assembly	7.7
7.2.1.3 Electrical connection	7.7
7.2.1.4 Power supply	7.7
7.2.2 General instruction	7.7
7.3. Display & terminal details	7.8
7.3.1 Terminal connection	7.8
7.4. Neuron-III salient features	7.9
7.4.1 Home screen display	7.9
7.4.2 Records (view-> day report and fault report)	7.9
7.4.3 Remote function (both MODBUS as well as digital input)	7.9
7.4.4 Lead and lag – pressure schedule (operator-> schedule)	7.9
7.4.5 Other interfaces and communication	7.9
7.4.6 Safeguard	7.9
7.4.7 Mimic LED for fault indicators	7.9
7.5. Input output description	7.10
7.5.1 X01: Power supply	7.10
7.5.2 X02: Digital inputs	7.10
7.5.3 X03: Analog input/output	7.10
7.5.4 X04: RS 485 communication	7.10
7.5.5 X05: Main motor relays	7.11
7.5.6 X06: Relays	7.11
7.5.7 X07: Relays	7.11
7.5.8 X08: 3 Phase input	7.11
7.6. Home screen	7.12
7.6.1 Important machine settings for users	7.14
7.7. Menu structure	7.16
7.7.1 Main menu	7.16
7.7.1.1 View	7.16
7.7.1.2 Operation	7.16
7.7.1.3 Fault report	7.17
7.7.1.4 Day report	7.17

Contents	Page No.
7.7.1.5 View service time	7.17
7.7.1.6 View cumulative time	7.17
7.7.1.7 VFD	7.18
7.7.1.8 Rental hours	7.18
7.7.2 Operator	7.18
7.7.2.1 Machine	7.18
7.7.2.2 Operator scheduler	7.19
7.7.2.3 Operator maintenance	7.19
7.7.2.4 Language	7.20
7.7.2.5 VFD control	7.20
7.7.2.6 VFD speed control	7.20
7.7.3 Service	7.21
7.7.3.1 Calibration (offset)	7.22
7.7.3.2 Programmable relay	7.22
7.7.3.3 Temperature	7.22
7.7.3.4 Maintenance	7.22
7.7.3.5 Clock	7.22
7.7.3.6 Digital input	7.22
7.7.3.7 Dryer input	7.23
7.7.3.8 Latitude/Longitude	7.23
7.7.3.9 VFD model	7.23
7.7.4 Customer care	7.23
7.8. Data interface	7.24
7.8.1 Analog output	7.24
7.8.2 DCS port	7.24
7.9. Troubleshooting	7.25
7.10. Construction	7.26
7.10.1 Dimension drawing	7.26
7.11. Example – scheduler setting	7.27
7.12. Revision details	7.28
7.13. Neuron III quick reference	7.29

Dis. Pressure	Discharge pressure
Dis. Temperature	Discharge temperature
HSP	High sump pressure
Temp	Temperature
DPAF	Differential pressure air filter
DPOF	Differential pressure oil filter
AF	Air filter
OF	Oil filter
Min	Minimum
Max	Maximum
VFD	Variable frequency drive
AO	Analog output
UL	Unload
En	Enable
Dis	Disable
L	Load
St	Stop
F	Fault
R	Run
Sby	Standby
STC	Start count
LDC	Load count
DD	Date
MM	Month
YY	Year
Ph Fail	Phase failure
Pr	Pressure
Tr	Temperature
DCS	Distributed control system
PR	Pressure
MMOL	Main motor overload
OL	Overload
NC	Not connected
PS	Pressure schedule
RST	Restart time
DTR	Delta to run
RTS	Run to stop
I/O	Input / Output
REM	Remote
RTU	Remote terminal unit

7.1 Technical specification

Definition	: Pre-programmed logic controller
Function	: Compressor control system & I/O monitoring
Part number	: 018362618
Software	: Embedded C
Rated voltage	: 24VAC + 15% -20%
Power consumption	: 10W (Max)
Ride through	: 30ms
Graphic display	: 2.9" Mono chrome graphics display
Display contrast	: Adjustable using software
Protections	: Low voltage
3 Phase detection	: Phase loss / reverse at the time of pressing START key
Keypad	: 11 key (Usage: up, down, right, left, enter, TAB, INFO, Esc, start, stop & reset) 11 LED (status, warnings and fault indication)
Language	: English, French, Portuguese, Italian, Spanish
Enclosure material	: ABS PC - Plastic
Dimensions	: 280 X 190 X 90 mm
Mounting	: Locking knob for panel tightening
Protection class	: IP55 from front panel only
Operating temp	: - 10°C ~ 50°C (14°F ~ 122°F)
Storage temp	: -10 to 70°C (14°F ~ 158°F)
Relative humidity	: <95% @ 50°C (122°F) without condensation
Certification	: CE, UL

For Technical support/assistance contact ELGI Customer Care
E-mail: ccs@elgi.com

Digital inputs:

Number of channel	: 8 Ports
Rated voltage	: 24VDC
Usage	: Emergency stop, motor overload, cooler over load, motor reverse rotation, DPOF,

Digital outputs:

Number of channel	: 8 Ports
Rated voltage	: 24VDC / 250VAC
Rated load	: 10A @ 250VAC

Coil rated current	: 21mA
Coil voltage	: 24VDC
Contact resistance	: max 100milliohms
Insulation resistance	: min 1000Megohms @ 500VDC
Usage	: 6 Pre-programmed (Main, star, delta, load/unload, ADV, fan motor), 2 by default programmed for trip and warn. programmable for warn, load, service, standby, trip, remote, ready and dryer if enabled.

Analog inputs:

Number of channel : 4

2 x 4-20mA inputs:

Range	: 0 to16 bar (0 to 232 psi)
Resolution	: 0.1bar (1 psi)
Accuracy	: ± 0.1bar (1 psi)
Usage	: Discharge pressure and sump pressure

2 x PT1000:

Range	: -10 to150° C (14 to 302°F)for 1 st channel -10 to 200° C (14 to 392°F)for 2 nd channel
Resolution	: 1°C (2°F)
Accuracy	: ±1°C (2°F)
Usage	: Discharge temperature, dew point /motor winding temperature software selectable

Analog outputs:

Number of channel	: 2
Range	: 1 to 5V DC
Resolution	: 1 mV
Accuracy	: ±25 mV
Usage	: Discharge pressure and discharge temperature

Communication ports:

Port 1	: RS485, MODBUS RTU (for DCS interface)
Port 2	: RS485, MODBUS RTU (for VFD parameter reading, analog input module)

7.2.1. Equipment safety

The device, before delivery, was checked according to the prescribed tests of the inspection scheme. In order to maintain this status through shipment and secure a safe operation, consider the notes and warning notes this instruction manual covers. The device should be operated by only trained personnel. Maintenance and repair should be performed only by trained, technical personnel, familiar with the associated dangers. The device can be operated without compromising its security within the certified environment condition.

7.2.1.1. Static discharge warning

This equipment is sensitive to electrostatic discharge, which can cause internal damage and affect normal operation. Follow these guidelines when you handle this equipment:

- Touch a grounded object to discharge potential static.
- Wear an approved grounding wrist-strap.
- Do not touch connectors or pins on component boards.
- Do not touch circuit components inside the equipment.
- Store the equipment in appropriate static-safe packaging when not in use.

7.2.1.2. Assembly

The place of assembly has to correspond to the class of protection. The ambient temperature in the installation position may not exceed the admissible temperature for the nominal use, specified in the data sheet. Not to use in wet condition.

The devices should be installed only outside of explosion hazardous areas!

7.2.1.3. Electrical connection

External connections are to be performed according to the respective national rules. Switch off the device before doing any wiring work. Do not connect or disconnect any wire when the device is powered on and operating.

7.2.1.4. Power supply

It is to be ensured that supply voltage corresponds with the specification on the type sign. If the device is switched on with other devices and/or mechanisms, then the effects have to be considered before switching and appropriate precautions taken. Do not connect welding or such high noise sources to the same line of controller supply.

7.2.2. General instruction

The following procedures and instructions should be followed closely to avoid damage to the control panel and its associated equipment. Reliability of the system depends upon proper installation and maintenance.

The device is to be examined with feed and storage to rule out damage from inappropriate handling. If the device

indicates damage, so that safe operation is not possible, then the device may be removed from operation.

Carefully unpack the system. Open the doors and inspect the cabinet, door, printed circuit board, and other components for the possibility of shipping damage. It is recommended that the cabinet be stored in a clean dry area until mounting takes place.

The signal cables and power cable should be separately routed.

The protective earth connection in the panel must be connected to field earth only.

Protection from direct sunlight

Since the electronic circuits must not be subjected to uncontrolled temperatures, place the cabinet in shade.

Protection from rain

Partial tightening of screws or doors allows water to enter the enclosure and cause irreparable damage to the circuitry. Provide canopy to avoid such damages.

Do not install equipment on structures subject to continuous vibration

Partially tightened wires or components in the cabinet disconnect during vibrations and cause irreparable damage to circuitry.

7.3 Display & terminal details

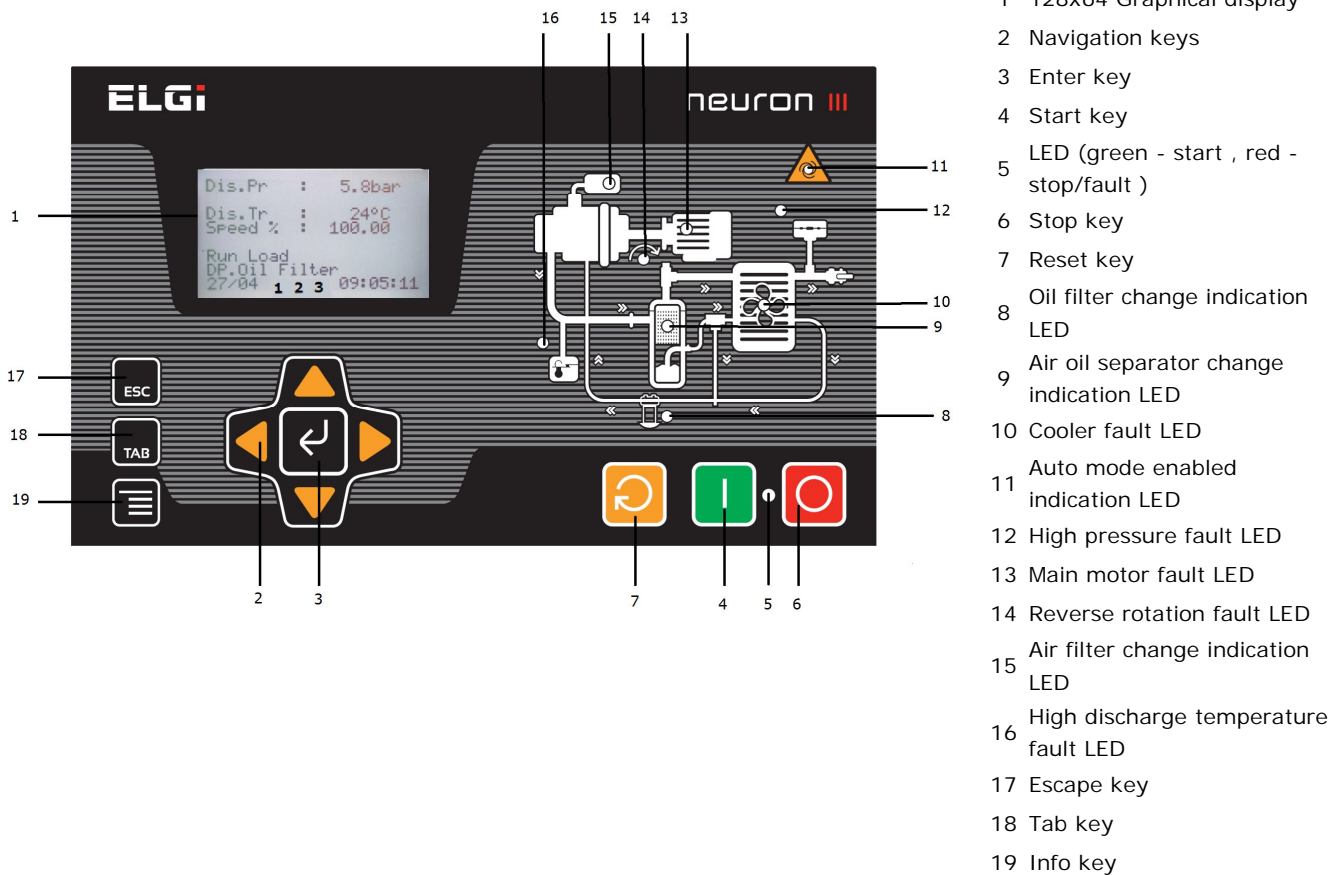

7.3.1. Terminal connection

- X01 - Power supply
- X02 - Digital input (8 Channel)
- X03 - Analog input (4 Channel) / output (2 Channel)
- X04 - Communication ports (2 Ports)
- X05 - Relay outputs (main, star, delta)
- X06 - Relay outputs (3 Nos)
- X07 - Relay outputs (2 Nos)
- X08 - Phase monitoring

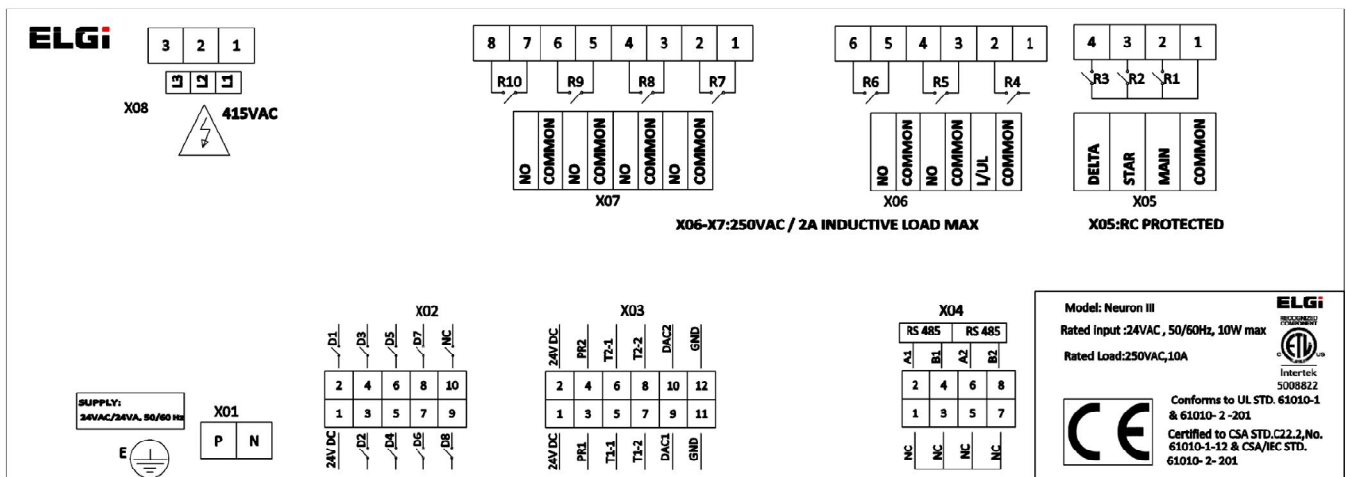

7.4.1. Home screen display

- Easy user interface 8 line graphical display and intuitive menu navigation keys

7.4.2. Records (view -> day report and fault report)

- 30 day reports (load hours, unload hours, run hours, stop hours, fault hours, standby hours, start count, load count)
- 99 fault reports
- Faults with date and time stamp, status of the machine at the time of fault etc.

7.4.3. Remote function (both from MODBUS as well as digital input)

- Remote loading and unloading
- Remote start and stop

7.4.4. Lead and Lag - Pressure schedule (Operator -> schedule)

- 32 pressure program (**one schedule should be in Sunday (first day of the week) 00:00 Hrs**)
- Setting hours considered as 24hr format irrespective of time format setting.
- Important parameters to customize - Day, On Time, OFF Time, Load Pr, Unload Pr

7.4.5. Other interfaces and communication

- VFD interface through MODBUS

- PC interface through MODBUS - To download reports and setting parameters
- 70 + Modbus parameters for DCS controls
- Dryer integration
- High, Low dew point warnings

7.4.6. Safeguard

- The 'Smart Logic' of NEURON III automatically decides the start delay required to ensure minimum wait time between successive starts of the compressor and dryer thereby increasing their lifetime.
- Start Inhibit till sump pressure is within safe limits to enhance the life of the compressor
- Low voltage & Short time Power interrupts detection to enhance the life of the contactors
- Low temperature start inhibit to avoid start-up overloads

7.4.7. Mimic LED for fault indications

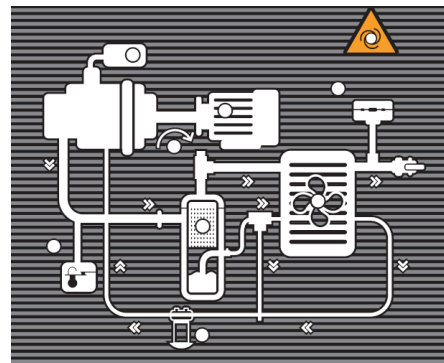

LED	Description
Auto	Continuous glow - to indicate the machine in auto power recovery mode. LED blink - when the machine is going to start irrespective of any start mode.
Air oil separator	Glows when 1. Air oil separator service is due - based on service hours 2. Pressure drop in separator is more than set value (if sensor is fixed).
Main motor overload	Glows when the main motor overload digital input is open.
Reverse rotation	Glows when the reverse rotation digital input is closed.
Cooler O/L	Glows when the cooler digital input is open
Pressure	Glows when 1. Analog pressure input is open (probe failure) 2. Discharge pressure is higher than set HSP 3. Sump. pressure is higher than set HSP (If sump pressure sensor is fixed)
Temperature	Glows when the 1. Analog Temperature Input is Open (Probe Failure) 2. Dis. Temperature is higher than set Trip temp.
Differential Pressure oil Filter (DPOF)	Glows when the 1. DPOF Digital input is open & DPOF is enabled 2. Oil filter service is due - based on service hours
Differential pressure air filter (DPAF)	Glows when the 1. DPAF digital input is open & DPAF is enabled 2. Air filter Service is due - based on service hours
Start & Stop	1. Glows in red when machine is stopped / idle 2. Glows in green when machine is running

7.5 Input output description

7.5.1 X01: Power supply

Pin	Function	Id	Active state
1	24V AC Phase	24 VAC P	-
2	24V AC Neutral	24 VAC N	-
3	24V Earth	Earth	-

7.5.2 X02: Digital inputs

Pin	Function	Id	Active state
1	Digital Inputs common - 24VDC	24VDC	-
2	Emergency stop	Emergency	Fault if open
3	Differential pressure oil filter	DPOF	Warn if open
4	Reverse rotation	Rev. Rot	Fault if closed
5	DPAF/REM load and unload	DPAF/REM L/UL	Warn or unload if open
6	Remote start stop control	Remote Start /Stop	Stop if open
7	Dryer warn/trip	Dryer Warn/Trip	Warn/Fault if open
8	Cooler motor overload	Cooler OL	Fault if open
9	Main motor overload	MMOL	Fault if open

7.5.3 X03: Analog input/output

Pin	Function	Id	Type	Range
1 & 3	24V DC discharge pressure	24V DC PR1	4 - 20mA	0 to 16 bar (0 to 232 psi)
2 & 4	24V DC sump pressure	24V DC PR2	4 - 20mA	0 to 16 bar (0 to 232 psi)
5 & 7	Discharge temperature	T1-1 T1-2	PT1000	-10 to 150°C (14 to 302°F)
6 & 8	** Dew point temperature / Ambient temperature/winding temperature	T2-1 T2-2	PT1000	-10 to 200°C (14 to 392°F)
9 & 11	Dis. pressure output (0 to 16 bar/0 to 232 psi) common ground	DAC1 GND	Voltage	1~5V
10 & 12	Dis. Temperature (-10 to 150°C / 14 to 302°F) common ground	DAC2 GND	Voltage	1~5V

7.5.4 X04 : RS 485 Communication

Pin	Function	Id	Active state
2	DCS interface A1	RS485 A	Modbus RTU protocol
4	DCS interface B1	RS485 B	
6	* VFD interface /AI module A2	RS485 A	Modbus RTU protocol
8	* VFD interface /AI module B2	RS485 B	
1	NC		
3	NC		
5	NC		
7	NC		

* If Dryer and VFD is enabled, AI module add-on will be used for dryer dew point

** If Dew point sensor and Winding temperature are used, Winding temperature shall be connected here

7.5.5 X05: Main motor relays

Pin	Function	Id	Active state
1	Common for main, star and delta contactors	Common	-
2	Main contactor	Main	Energized
3	Star contactor	Star	Energized
4	Delta contactor	Delta	Energized

7.5.6 X06 : Relays

Pin	Function	Id	Active state
1	Common - load relay	Common	Load when energized
2	Load relay	L/UL	
3	Common - fan relay	Common	FAN ON when energized
4	Fan relay	NO	
5	Common - auto drain valve relay	Common	ADV ON when energized
6	Auto drain valve relay	NO	

7.5.7 X07 : Relays

Pin	Function	Id	Active state
1	Common - Programmable relay	Common	Energized
2	Programmable relay	NO	
3	Common - Programmable relay	Common	Energized
4	Programmable relay	NO	

7.5.8 X08: 3 Phase input

Pin	Function	Id	Type	Range
1	R Phase	L1	AC Voltage	150 to 550 V AC
2	Y Phase	L2		
3	B Phase	L3		

The home screen will show discharge pressure , discharge oil temperature ,VFD speed % (if VFD enabled), compressor status, warn messages, compressor mode selection details and date & time

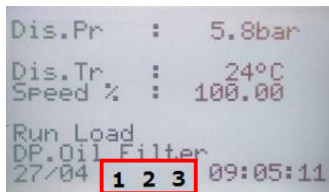

Compressor mode selection details:

1. PS - Pressure schedule enabled ,
UL - unload mode enabled,
PS & UL disabled the space will be shown as empty
2. L or R or D - compressor start from - Local or remote or DCS,
3. A or M - Auto restart enabled or auto restart disabled.
For more details refer machine settings in operator menu.

Shortcut key usage

When the controller is in home screen, you can access below listed parameters using the shortcut keys.

"RIGHT" - Live analog values

- Live differential pressure (displays only if sump pressure enabled)

- Live sump pressure (displays only if sump pressure enabled)
- Live Pt1000 temperature (displays only if DRYER ON enabled)

"UP" - Set analog values

- Set load pressure
- Set unload pressure
- Set start sump pressure (displays only if sump Pressure enabled)
- Max differential pressure (displays only if sump Pressure enabled)

"DOWN" - Today report

- Load and stop hours
- Unload and fault hours
- Run and standby hours
- Start count and load count

TAB Key - For changing the language

HELP Key - For contrast adjustments



Message 1 - Compressor status message

Status	Description
Ready	Ready for start
Star	Motor running in star
Run	Motor running in delta
Run load	Compressor in load
Run unload	Compressor in unload
Stop busy	Stop sequence in progress
Emergency stop	Emergency stop push switch is ON
Start inhibit xx.x	During the start, if the sump pressure is higher than the set start sump pressure value, you will see this message. XX.X denotes the live sump pressure value. The compressor starts only if the sump pressure value goes below the set value.
Temperature inhibit ±XX	During the start, if the discharge temperature is lower than the set inhibit temperature value, you will see this message. ±XX denotes the live discharge temperature value. The compressor starts only if the discharge temperature value goes above the set value.
Start inhibit "seconds"	If sump pressure is not used (disabled) then the controller will ensure minimum 60 seconds delay between the stop and the start. Count stops if "STOP" key is pressed
Auto restart "seconds"	If compressor is in auto mode, the controller will ensure minimum delay (user set, e.g. 60 sec) between stop and start. count stops if "STOP" key is pressed
Start ack wait...	This message is displayed after a fault is cleared and waiting for user acknowledgement. By pressing "RESET" key user can acknowledge.
Standby	Compressor in standby

Message 2 - Compressor fault message

Fault	Description
Pr. Probe failure	Discharge pressure sensor probe failure
Tr. Probe failure	Temperature sensor probe failure
Sump pr. probe failure	Sump pressure sensor probe failure, if sump pressure is enabled
HSP (AS)	Case 1: sump pressure is enabled
	If sump pressure exceeds the set high sump pressure value.
HSP (AD)	If discharge pressure exceeds the set high sump pressure value.
Cooler	If the cooler digital Input opens due to Cooler fault
Main motor overload/ VFD error	IF the MMOL digital input opens due to main motor over load. VFD error if VFD control is enabled.
Rev rot / Ph fail	If the rev rot input closes when motor running due to motor reverse rotation or Phase failure.
Trip temperature	If the discharge temperature exceeds the set trip temperature value.
Sump Pressure Not Developing	After the Start, The sump pressure should be at least 0.3 bar/4psi after star delay expires. If this is NOT achieved this Fault occurs , if sump pressure is enabled.
Power failure	If the mains supply is interrupted for more than 20 msec
Low voltage	If the mains supply voltage is less than the 75% of rated voltage. Compressor is tripped & All controller operation is halted until the mains supply Comes back to normal (at least 85% of the rated)
Dis. pressure Not developing	After the Load, The discharge pressure should be at least 0.5 bar/7psi in 5mins. If this is NOT achieved this fault occurs
Dryer IP trip	If dryer is enabled with trip, if dryer trip occurs, this fault message will be shown
Dryer low DP trip	When dew point temperature is less than set value.
Temperature not developing	If the discharge temperature not raised above the inhibit temperature before the set inhibit temperature time.
Winding temp. high	If CV20 variant selected or winding temperature enabled, it will trip the compressor based on SET value of MOTOR WINDING temperature
Winding temp. fail	If CV20 variant selected or winding temperature enabled, it will trip the compressor if sensor open

Message 3 - Compressor warning message

Warning	Description
DPAF	If DPAF Digital Input is Open and DPAF ON in factory setting
DPOF	If DPOF Digital Input is Open and DPOF ON in factory
Dryer Probe Failure	When Ch-4 analog sensor input fails
Dryer Off - Low DP warn	When Ch-4 Dew point temp. is less than Set value
High Dew Point	When Ch-4 Dew point temp. is greater than Set Value
High Differential Pressure	When the difference between Sump. Pressure and Discharge Pressure exceeds the Set Pressure. (Only in Sump Pr. Enabled condition)
Warn Temperature	When Discharge temp. exceeds the set warntemperature (Default is 105Deg C/Deg F)
Change Oil Filter	When service remaining Hr. reaches 0000 Hrs
Change Air Filter	When service remaining Hr. reaches 0000 Hrs
Change Oil	When service remaining Hr. reaches 0000 Hrs
Change Grease	When service remaining Hr. reaches 0000 Hrs
Change Separator	When service remaining Hr. reaches 0000 Hrs
Change Valve kit	When service remaining Hr. reaches 0000 Hrs
Dryer Off - IP Warn	If Dryer Digital Input is Open and dryer warn is selected in the input
Calibration error	When there is error in sensor calibration
Winding temp Exceeded	If CV20 variant selected or winding temperature enabled and if the temperature exceeds [SET value-10] of MOTOR WINDING temperature

7.6.1 Important user machine settings

1. Control mode

Local - Users can start and stop the compressor by using local start/stop key

Remote - Users can start and stop the compressor by using potential free digital input. (refer digital input connector - X04).

DCS - Users can start and stop the compressor by using RS485 modbus communication port (refer connector - X07).

NOTE

In remote and DCS mode, the start/stop button in the controller is inactive. In case of emergency, stop the compressor using the "emergency stop push" button available in the front panel. This is applicable across all types of control mode.

2. Unload mode

If this is enabled, the compressor operates only in unload mode and never in load mode. (This mode is used for service and maintenance purposes.)

3. Auto restart

If this is enabled, the compressor operates automatically after a power outage and resumes based on the previous condition. The default delay is 30* sec. Warn RST delay delays the compressor start if power resumes and Auto Restart Mode is ON.

*If compressor recover from standby, restart delay is 10 sec.

4. Load / Unload pressure

The compressor operates between load pressure and unload pressure based on compressed air utilization. You can set load/unload pressure based on the requirement within the operating pressure band zone.

5. Star delay

Star to delta change over delay time. Default 6 sec delay given in the factory.

6. DTR delay

From delta change over to load delay time. Default 3 sec delay given in the factory.

7. RTS delay

The normal stop of the compressor will unload and wait for this delay time to stop the compressor. The default delay is 5 sec.

8. Standby time

The compressor will switch to standby if unloading exceeds the specified time. The default delay is 5 mins.

Standby resume - If the actual pressure is less than the load pressure, then the compressor will restart automatically after 10 sec delay. If demand from the standby stop comes after 10 sec, the compressor will start

immediately. This feature helps save the energy if very little compressed air is used.

NOTE

If the compressor is started more than the specified number of cycles per hour through the Standby sequence, then the system does not enter into the Standby stop sequence until the existing hour is completed. Next, the Standby override will appear on the screen.

9. Start/Stop per hour

The system will warn if the compressor is started more than the specified number of cycles per hour. The default timeframe is 5 per hours.

10. Auto drain valve

The auto drain valve is a special feature to prevent water from entering into compressed air delivery. This function resets the drain valve to ON and OFF based on the time specified in the menu. The default setting is 5 Sec ON in 4-min intervals. You can adjust the ON and OFF time based on the requirement.

11. Low dew point

The system will warn/trip if the dew point temperature is less than the set value (if the dryer is enabled).

12. High dew Point

The system will warn if the dew point temperature is higher than the set value (if the dryer is enabled).

13. Load/Unload Source

Local: Load/Unload pressure is based on load/unload settings in the controller.

Remote: Selection from digital input– remote load/unload can be operated from remote through a wired switch.

DCS: Load/Unload can be operated from DCS (load/unload command should be given continuously in the interval ≤ 3 sec) Ensure master control bit in enabled condition.

NOTE

The compressor starts working in local load and unload mode if communication is lost in DCS mode.

14. VFD Function

VFD speed percentage will appear in the HOME screen once VFD mode is enabled in the factory setting.

You can also view the below VFD parameters by accessing the view->VFD menu:

- Voltage in V
- Current in A
- Frequency in Hz
- Power in KW
- RPM
- Status of the VFD

VFD Mechanism

- The machine operates at the set minimum speed till it reaches the RUN LOAD condition at start-up.
- The machine will run at the set unload speed when it is in unload, which may be remote or DCS unload or when discharge pressure is > unload pressure.
- The machine will run at optimum speed when optimum is ON. This works only under the load condition. Under the unload condition, it follows the unload speed.
- The machine will run at calculated speed between minimum and maximum speed based on machine usage and when the machine is under load with optimum OFF.

7.7 Menu structure

Press any one of the following keys ▲▼◀ and ▶ to enter main menu

7.7.1 Main Menu

Dis. Pr	: 0.0 bar / 0 psi
Dis. Tr	: 25°C / 77°F
Status	:
	View
	Operator
	Service
	Factory
	Customer care
	Admin

7.7.1.1 View

In the view menu, you can view the set parameters, but you cannot edit any of them - no password required.

View	Operator
	Fault report
	Day report
	Service time
	Cumulative time
	VFD
	Rental hours

7.7.1.2 Operator

LEVEL 1	LEVEL 2	LEVEL 3	LEVEL 4	
View	Operator	Mode	Control mode	Local / Remote / DCS
			Auto restart	On/ Off
			Pressure unit	Bar/psi
			Temperature unit	Fahren / centi
		Pressure	Unload pressure	X X . X b or p (bar or psi)
			Load pressure	X X . X b or p
			Pr. schedule	ON/ OFF
		Delay	Warn RST delay	X X X s (second)
			Star delay	X X s
			DTR delay	X X s
			RTS delay	X X s
			Standby time	X X m (minute)
			St/Sp PH	X X
		DCS port	Type	Modbus
			ID	X X
			Baud	9600/19200
			Parity	None / Even / Odd
			Length	8 / 7
			Stop bit	2 / 1
		Temperature	Trip temperature	X X X C or F
			Warn temp	X X X C or F
			Fan temp	X X X C or F
		Rating	XXXXXXXXXX	
		Fab No.	XXXXXXXXXX	

7.7.1.3 Fault Report

Use Δ and ∇ to select the fault record number (1 to 99). The latest fault will be displayed in the first position. For fault message details refer the "Fault Message" table.

LEVEL 1	LEVEL 2	LEVEL 3
View	Fault report	Fault message
		Date : DD/MM/YY
		Time : HH:MM:SS
		Dis.Pr : X X .X
		Dis.Tr : X X X
		Status : RDY/ACK/STAR etc.,

7.7.1.4 Day Report

The day report explains the usage pattern of the compressor day wise for last 30 days. Use Δ and ∇ to select the record number (1 to 30). The latest report will be displayed in record 1.

LEVEL 1	LEVEL 2	LEVEL 3
View	Day report	Date: DD/MM/YY
		L: X X Hours St: X X Hours
		UL: X X Hours F: X X Hours
		R: X X Hours Sby: X X Hours
		STC: X X X LDC: X X X X X

L- Load, St - Stop, UL - Unload, F- Fault, R- Run, Sby- Standby, STC - Start Count, LDC - Load Count

7.7.1.5 View Service Time

For consumable parts, the remaining life will appear in the view menu. Every run hour, the count will decrements by one hour. Once it reaches zero, an alarm message will pop up and the counter will show negative hours.

LEVEL 1	LEVEL 2	LEVEL 3
View	Service time	Remaining AFCT: X X X X X hours
		Remaining OFCT: X X X X X hours
		Remaining OSCT: X X X X X hours
		Remaining OCT: X X X X X hours
		Remaining RGT: X X X X X hours
		Remaining valve kit: X X X X X hours

7.7.1.6 View Cumulative Time

From the compressor commissioning to till date , the run hours and utilization pattern will be displayed in the menu.

LEVEL 1	LEVEL 2	LEVEL 3
View	Cumulative time	Load X X X X X hrs: X X Min
		Unload X X X X X hrs: X X Min
		Run X X X X X hrs: X X Min
		Stop X X X X X hrs: X X Min
		Fault X X X X X hrs: X X Min
		Standby X X X X X hrs: X X Min
		Start count X X X X X
		Load count X X X X X X X X
		Utilisation X X %

7.7.1.7 VFD

If VFD is enabled in the controller and VFD communication port is connected, you can view the following VFD parameters in Neuron III.

- Voltage in V
- Current in A
- Frequency in Hz
- Power in KW
- RPM
- Status of the VFD
- Run hours based on VFD speed %

< 40% speed	XXXX hours
40~50% speed	XXXX hours
51~60% speed	XXXX hours
61-70% speed	XXXX hours
71-80% speed	XXXX hours
81~90% speed	XXXX hours
91~100% speed	XXXX hours

7.7.1.8 Rental hours

If you select rental hours in the operator menu, you can view the run hours and the utilization pattern of the compressor in the view menu.

To reset the rental hours, you have to choose “rental off” and then “rental on” in operator menu.

Load	X X X X X hrs: X X Min
Unload	X X X X X hrs: X X Min
Run	X X X X X hrs: X X Min
Stop	X X X X X hrs: X X Min
Fault	X X X X X hrs: X X Min
Standby	X X X X X hrs: X X Min
Start count	X X X X X X
Load count	X X X X X X X X

7.7.2 Operator

This option requires a password to adjust operator settings within the set limits.

Operator	Machine
	Scheduler
	Maintenance
	Language
	Change password
	VFD control
	Rented hrs setting
	Last serviced

7.7.2.1 Machine

The machine settings available are listed in the below table.

#	Item	Min	Max	Option	Default	Unit
Mode						
1	Control mode	-	-	loc/rem/dcs	loc	-
2	Auto restart	-	-	on / off	off	-
3	Pr unit	-	-	bar / psi	bar/psi	-
4	Tr unit	-	-	cen / far	cen	-
Pressure						
5	Unload pressure	≥ load pressure	≤ max unload pressure	-	Based on compressor pressure rating	bar/psi
6	Load pressure	4.0bar(58psi)	≤ unload pressure -	-		bar/psi
Set Delay						
7	Warn RST	30	250	-	30	second
8	Star	6	20	-	6	second
9	DTR	10	60	-	3	second
10	RTS	5	30	-	5	second
11	Standby	1(VFD),3(Non-VFD)	99	-	3	minute
DCS Port						
12	Type	-	-	Modbus	-	
13	ID	01	99	-	01	-
14	Baud	-	-	9600/19200	9600	bps

#	Item	Min	Max	Option	Default	Unit
14	Baud	-	-	9600/19200	9600	bps
15	Parity	-	-	None/Even/ Odd	None	
16	Length	-	-	8 / 7	8	-
17	Stop bit	-	-	2 / 1	1	-
Auto Drain Valve						
18	Off time	1	180	-	4	minute
19	On time	1	15	-	5	Second
Load / Unload Source						
20	LD / UL Source	-	-	Loc / Rem/ DCS	Loc	-
Set dew point						
21	Low dew point	-6°C(21°F)	2°C(36°F)		-2°C(28°F)	Cen
22	High dew point	6°C(43°F)	12°C(54°F)		8°C(46°F)	Cen
Contrast adjust						
24	Contrast adjust	10	100		50	%

7.7.2.2 Operator - Scheduler

If you enable the pressure scheduler, then you can view and access the below table in edit mode. Use Δ and ∇ to select the pressure scheduler number (1 to 32). For details, refer to "Example - scheduler setting".

#	Item	Min	Max	Option	Default	Unit
1	Day	-	-	Sun to Sat / (--- means no schedule)	---	-
2	Action	-	-	on / off	off	-
3	Time HH	00	23	-	00	Hour
4	Time MM	00	59	-	00	Minute
5	Unload Pressure	\geq Load pressure + 0.5bar(7psi)	\leq Max unload pressure	-	7.5bar (109psi)	bar/psi
6	Load pressure	4.0 bar(58psi)	\leq Unload pressure -	-	5.5bar	bar/psi

(one schedule should be in Sunday (first day of the week) 00:00 Hrs) Then Press "Enter" to set the following

7.7.2.3 Operator - Maintenance

If you modify the settings for the below consumables, you can select the yes option to restart the service counter from the default

#	Item	Min	Max	Option	Default	Unit
1	AF changed	-	-	no/yes	no	-
2	OF changed	-	-	no/yes	no	-
3	OS changed	-	-	no/yes	no	-
4	Oil changed	-	-	no/yes	no	-
5	Re-grease	-	-	no/yes	no	-
6	Valve kit	-	-	No/yes	No	-

7.7.2.4 Language

Default is English. You can choose any one of the given languages.

#	Item
1	English
2	Portuguese
3	Francais
4	Italiano
5	Spanish

7.7.2.5 VFD Control

Item	Min	Max	Default	Unit
Optimum Speed	on/off	on/off	off	
P-Gain	1	50000	250	
I-Gain	1	5000	500	
I-Time	1	200	20	
Max. Speed	Factory settings can be viewed here			RPM
Min. Speed				RPM
Optimum Speed				RPM
UL Speed				RPM
High (5v)				RPM
Low (1v)				RPM

7.7.2.6 VFD Speed Control

Optimum speed: The compressor runs at optimum speed under load with optimum ON (Operator menu).

PI speed control: In the "Run Load" condition, the compressor operates at calculated speed between Min and Max speed depending on air utilization/usage.

Setting the P value

P-Gain - Range: 1-50000. This gain occurs over a full range. The recommended setting is 20-1000.

A proportional-integral controller (PI controller) is a control loop feedback mechanism used in industrial control systems and a variety of other applications requiring continuously modulated control.

Proportional-Integral controller results from the combination of the proportional and the integral mode. This mode is also called as the proportional plus reset action controller

Effect of Proportional Value

The proportional term produces an output value that is proportional to the current error value. The proportional response can be adjusted by multiplying the error by a constant K_p , called the proportional gain constant.

A high proportional gain results in a large change in the output for a given change in the error. If the proportional gain is too high, the system can become unstable. In

contrast, a small gain results in a small output response to a large input error, and a less responsive or less sensitive controller. If the proportional gain is too low, the control action may be too small when responding to system disturbances.

Effect of Integral Value

The contribution from the integral term is proportional to both the magnitude of the error and the duration of the error. The integral term accelerates the movement of the process towards set point and eliminates the residual steady-state error that occurs with a pure proportional controller. However, since the integral term responds to

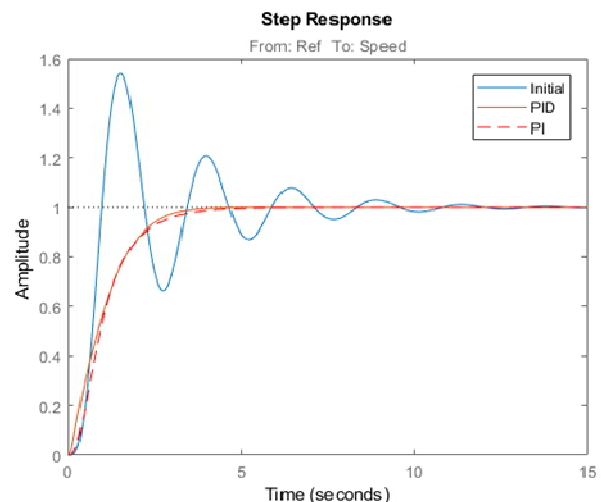

Parameter	Rise time	Overshoot	Settling time	Steady-state error	Stability
Kp	Decrease	Increase	Small change	Decrease	Degrade
Ki	Decrease	Increase	Increase	Eliminate	Degrade

accumulated errors from the past, it can cause the present value to overshoot the set point value

Effect of change in Kp(Proportional value) & Ki (Integral value) listed below.

Example:

Sample 1:

If P-Gain=20 and the difference between set pressure and actual pressure \geq 5 bar (73 psi), then the PI loop activates.

Sample 2:

If P-Gain=1000 and the difference between set pressure actual pressure \geq 0.1 bar (1 psi), then the PI loop activates.

Set a higher P-Gain value if receiver capacity is high and the reverse holds true.

Setting the I-Gain value

I-Gain - Range: 1-5000. This gain occurs over a full range. The recommended setting is 50- 1000.

The recommended value is 125 to 250 in our case. Anything less than 125 will be more stable.

A lower setting enables the system to be tolerant to the error. A value of 50 for I-Gain will enable the system to correct the error only if the pressure difference between set and actual pressure exceeds 0.020 bar / 0.3 psi.

The higher the setting, the more sensitive the system becomes to very small changes.

E.g. A value of 1000 for I-Gain makes the system sensitive to a 0.001 bar / 0.01 psi difference. A very high value and sensitive system (low receiver capacity) will drive the system into a completely unstable state. Always try to set lower values for I-Gain.

Setting I-Time

I-time - Range: 1-200. This indirectly counts the scan time. The recommended value is 15-20.

The higher the value, the more delay will be on the application of correction calculated based on I-Gain and the reverse is true.

Min speed: The compressor remains in min speed up to the start "Run Load" condition during start. If demand is very little, the compressor will run at minimum speed.

Unload speed: The compressor runs at set unload speed during unload. This is irrespective of all unload modes like Remote, DCS and local unload.

Pre-checks that must be performed before starting the compressor under VFD control

- VFD should be enabled in Factory -> VFD settings to

read and write between VFD and Neuron III.

- View the VFD RPM range in the factory AO scaling menu to ensure MODBUS communication exists between VFD and Neuron III. Current VFD RPM appears here, if communication no longer exists.
- Ensure min reference of AO scaling > VFD Parameters 3-02 and 4-11 and max reference of AO scaling < VFD parameters 3-03 and 4-13.

NOTE

The VFD factory settings in the controller are synchronized with VFD. It is not recommended to adjust the settings in VFD.

Rental hrs settings

Rental-ON: If selected, then a separate timer is recorded for rental hrs of load, unload, run, stop, fault, and standby/STC/LDC. It can be viewed in the view menu only when the rental hour is on.

To reset the rental hour, select "rental off" and then "rental on".

Last serviced

AMC service - If you select yes, the last AMC serviced updates with the current date. You can then view it in the customer care menu.

Spares replaced - If you select yes, the last spares replaced updates with the current date. You can then view it in the customer care menu.

Regular service - If you select yes, the Regular service updates with the current date. You can then view it in the customer care menu.

7.7.3 Service

Password required.

The setting changes should be made by ELGi authorized service technicians only. Any attempt to change service settings by unauthorized people may lead to compressor malfunction and the warranty becoming void.

Service	Sensor Offset
	Relay
	Temperature
	Maintenance
	Clock
	Self-Test
	Password
	Digital Input
	Dryer Input
	Unload Mode
	Lat /Lon
	VFD_model

7.7.3.1 Calibration (offset)

If any deviation occurs in the pressure and temperature between that displayed in the controller and that in the master gauge, approach the ELGI service engineer.

7.7.3.2 Programmable relay

Select programmable relay 1 or 2 using the Δ and ∇ keys. Then press "Enter" to assign any one of the following functionalities to the relay.

#	Item
1	Warn
2	Load
3	Service
4	Stand by
5	Trip
6	Remote
7	Ready

Default

Relay 1 = Warn
Relay 2 = Trip

NOTE

If Dryer is enabled, then programmable relay 2 is not user programmable. It is used for automatic dryer control.

7.7.3.3 Temperature

Fan Temperature - Fan relay will energize if discharge temperature reaches the set value. It will de-energize when the temperature comes below 75°C from the set value. Alternatively, fan start/stop is allowed for 15 times/ per hour. Beyond 15 times, the fan will not switch off.

The above logic will work only if the fan input connected to relay output of the controller (Ref: 7.5.6 X06: Relay in page No: 7.11).

Inhibit temperature – If you enable this setting and Temperature inhibit is already enabled in factory settings, the compressor will start when the discharge temperature is higher than the set value.

Temperature inhibit time - The compressor will wait for this specified time to reach the inhibit temperature. If not, it trips as temperature is not building. .

#	Item	Min	Max	Option	Default	Unit
1	Fan temp	On 95°C	Off	-	-	C/F
2	Inhibit temp	-5°C (23°F)	5°C (41°F)	-	0°C (32°F)	C/F
3	Tr_ initial time	5	90	-	5	min

7.7.3.4 Maintenance

Here you can feed the filter lift time. This timeframe will vary depending on the model and filter. Contact Elgi for more information.

You used to register the filter replacement in operator -> Maintenance by choosing Yes/No option. Once you choose Yes in operator then filter life time will be updated.

#	Item	Min	Max	Option	Default	Unit
1	Set AFCT	0000	30000	-	2000H	Hour
2	Set OFCT	0000	30000	-	2000H	Hour
3	Set OSCT	0000	30000	-	4000H	Hour
4	Set OCT	0000	30000	-	2000H	Hour
5	Set RGT	0000	30000	-	2000H	Hour
6	Set Valve Kit	0000	30000	-	2000H	Hour

7.7.3.5 Clock

Here the real time clock settings can be done. 24 hrs format will be applicable for all menus and features related to clock settings, Whereas 12 hrs time format is applicable for the home screen only.

#	Item	Min	Max
1	Hour	00	23
2	Minute	00	59
3	Second	00	59
4	Date	01	31
5	Month	01	12
6	Year	00	99
7	Day	Sun/Mon/Tue/Wed/Thu/ Fri/Sat	

Daylight saving

Daylight saving settings will add 1 or 2 hours from the current GMT time. If you choose daylight option as off, the clock will revert back to GMT time.

#	Item	Min	Max
1	Date format	DD/MM/YY	MM/DD/YY
2	Time format	12 hr	24 hr
3	Day light savings	0	2

7.7.3.6 Digital input

Configuration of DI-4 (DPAF or Remote Load/Unload) can be viewed from this menu. (if the load/unload source is selected as remote in operator -> machine settings). Then the digital Input will configure for remote Load/Unload.

7.7.3.7 Dryer input

Dryer digital input DI-6 can be configured for warn or trip. This input will be effective if the dryer is ON in factory -> dryer.

7.7.3.8 Latitude/Longitude

This option involves deg, min, and sec with NE, NW, SE, and SW format.

The Latitude/Longitude entry helps ELGi to determine the location of the compressor on which air alert is equipped.

7.7.3.9 VFD_model

A list of VFD models appears here for you to select a pressure-based speed, based on customer requirement.

7.7.4 Customer care

Dis. Pr	:	6.0 bar/ 87psi
Dis. Tr	:	32°C (90°F)
Status	:	S/W Version
URL	:	www.elgi.com
E-mail	:	ccs@elgi.com

Neuron III supports two types of data interface

- Analog output
- DCS Port

7.8.1 Analog output

Two channels are available as analog output.

Channel -1 for discharge pressure values 0.0 to 16.0 bar / 0 to 232 psi converted into 1 to 5V.

Channel -2 for discharge temperature values from -10 to 150°C / 14 to 302°F converted into 1 to 5V.

NOTE

If analog input probe failure occurs, analog output becomes 0V by default.

7.8.2 DCS port

The DCS port is a Modbus RTU type to interface to the generic DCS system.

You can set the device ID in the "Operator/ Machine/ DCS Port" menu. Also the baud rate, parity, data length, and stop bit are user settable.

7.9 Troubleshooting

S. NO	Failure symptoms	Possible causes	Remedies
1	No display in LCD Screen & Backlight was not glown	No input supply	Check incoming AC input
		Transformer failure.	Please check the controller input voltage at connector X08. Voltage should be 24V \pm 15% VAC.
		Controller failure.	Change the controller.
2	Key not functioning Note: Controller keys	Key not responding	Check any key stuck / Flat. If any change Controller
		Key struck / Flat	Change the controller.
3	"Low voltage" message in display.	Controller Input voltage less than 18VAC	Until will start functioning, once input voltage recovered to nominal or with in specification (415 V +10% - 15 %)
4	"Pr. probe failure" message in display	Loose connection in connector position (X03 - 1, 3) & (X03 - 2, 4) .	Check the loose connection at both end - Controller and pressure sensor side.
		Pressure sensor failure.	Change the Pressure sensor.
		Controller failure	Check the voltage across (X03 - 3) & (X03-4) with Gnd, voltage should be b/w 0.4 to 2VDC. If it is different change the controller.
5	"Tr. probe failure" message in display	Loose connection in connector position (X03 - 5, 7) & (X03 - 6, 8)	Check the loose connection at both end - Controller and Temp sensor side.
		Temperature sensor failure.	Change the Temperature sensor.
		Controller failure	Check the voltage across (X03 - 7) & (X03-8) with Gnd, voltage should be 3.3 VDC. If it is different change the controller.
6	"Emergency stop" "MMOL" "Cooler OL" "Dryer trip" "Rev rot/Ph fail" message in display	Loose connection in connector position X02 - 1 to 9).	Check the loose connection at controller end.
		Switch got struck	Check either the external switches got sturck / Fault not cleared
		Controller failure	Change the controller.
7	Motor not driving	Controller failure	Disconnect the X05, X06 & X07 connector, Check the relay working by switching on the start key (X05 -1) with (X05- 2, 3 & 4) & (X06 -1) with (X06-2). Note: Ccheck in the continuity mode.
8	"Phase loss/ Reverse" message in display	Loose connection in connector position X08 - 1, 2 & 3.	Check the loose connection at controller end.
		Controller failure	Check for the X05 connection X08(1- R, 2-Y, 3 -B), Still the same error change the controller

- Plastic enclosures
- IP55 polyethylene front keypad
- Inputs and Outputs through terminal block
- Enclosure dimensions 280 X 190 X 90 mm

7.10.1 Dimension drawing

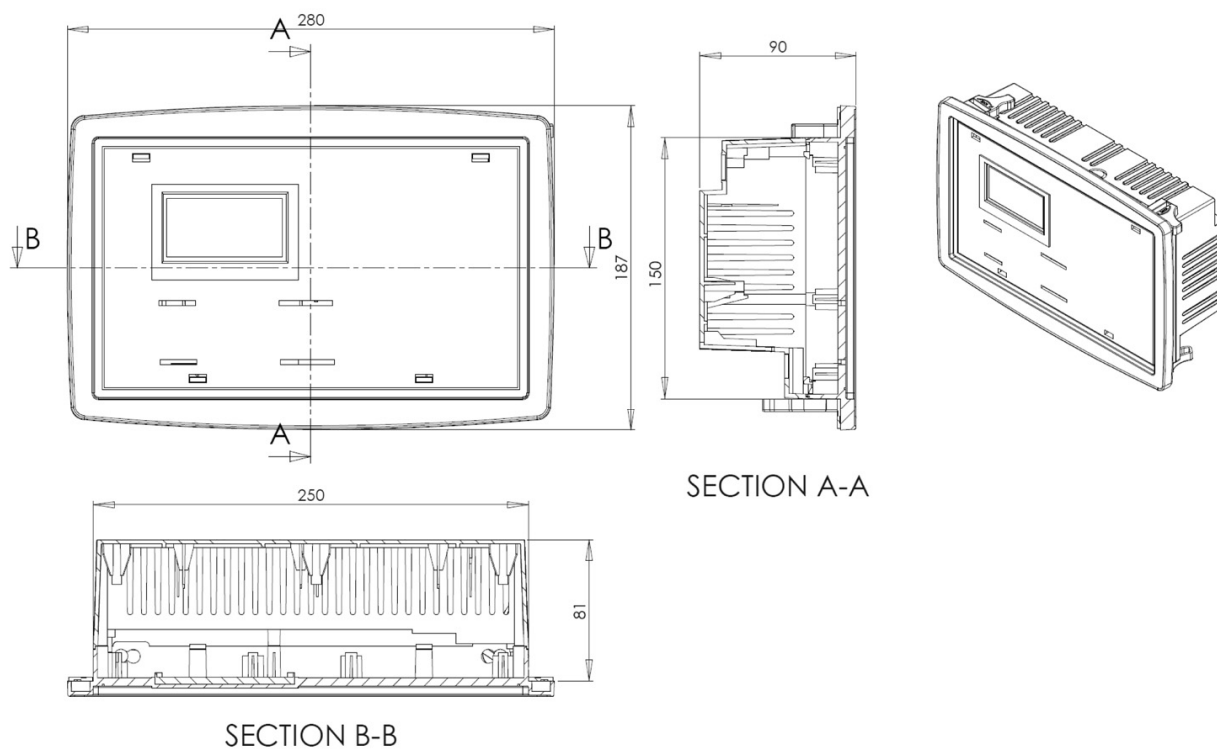

7.11 Example – scheduler setting

Scheduler settings are considered when:

1. End customer usage is 6 bar (87 psi)
2. Pressure variation in the air pipe is less than 0.1bar (1 psi)
3. All 3 compressors connect to a single/common header or a common receiver
4. All 3 compressors connect to a common header or a common receiver

Pressure schedule settings in Neuron III												
	Comp-1				Comp-2				Comp-3			
	ON	OFF	Load bar (psi)	U/L bar (psi)	ON	OFF	Load bar (psi)	U/L bar (psi)	ON	OFF	Load bar (psi)	U/L bar (psi)
Monday	Lead				Lag				Lag			
	8:00	18:00	7 (102)	7.5 (109)	8:00	18:00	6.6 (96)	7.2 (104)	8:00	18:00	6 (87)	6.8 (99)
Tuesday	Lag				Lead				Lag			
	8:00	18:00	6 (87)	6.8 (99)	8:00	18:00	7 (102)	7.5 (109)	8:00	18:00	6.6 (96)	7.2 (104)
Wednesday	Lag				Lag				Lead			
	8:00	18:00	6.6 (96)	7.2 (104)	8:00	18:00	6 (87)	6.8 (99)	8:00	18:00	7 (102)	7.5 (109)
Thursday	Lead				Lag				Lag			
	8:00	18:00	7 (102)	7.5 (109)	8:00	18:00	6.6 (96)	7.2 (104)	8:00	18:00	6 (87)	6.8 (99)
Friday	Lag				Lead				Lag			
	8:00	18:00	6 (87)	6.8 (99)	8:00	18:00	7 (102)	7.5 (109)	8:00	18:00	6.6 (96)	7.2 (104)
Saturday	Lag				Lag				Lead			
	8:00	18:00	6.6 (96)	7.2 (104)	8:00	18:00	6 (87)	6.8 (99)	8:00	18:00	7 (102)	7.5 (109)
Sunday	00:00hrs As required ON/Off has to be set. This is mandatory setting.											

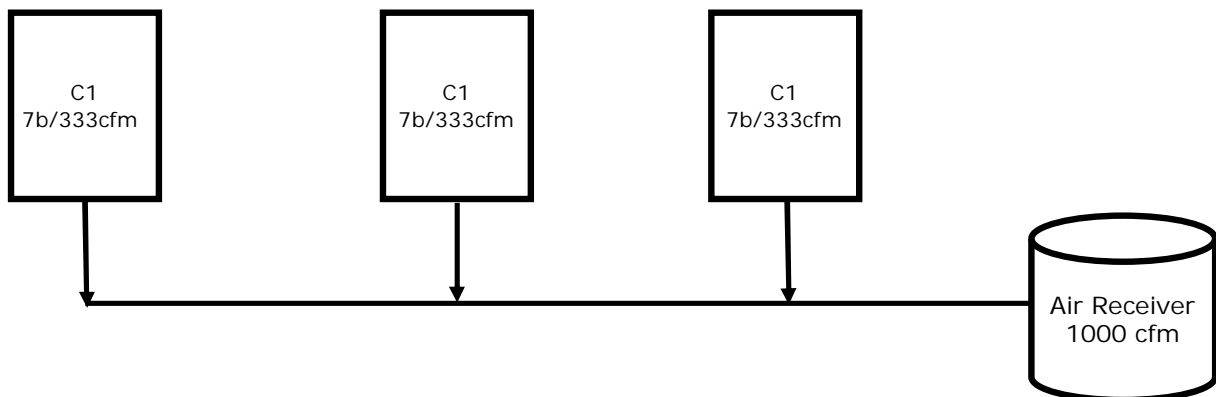

Example - scheduler setting

Weekly utilization

Comp ->	Air demand: 100%			Air demand: 75%			Air demand: 50%			Air demand: 25%		
	C1	C2	C3	C1	C2	C3	C1	C2	C3	C1	C2	C3
Day-1	100	100	100	100	100	25	100	50	0	75	0	0
Day-2	100	100	100	25	100	100	0	100	50	0	75	0
Day-3	100	100	100	100	25	100	50	0	100	0	0	75
Day-4	100	100	100	100	100	25	100	50	0	75	0	0
Day-5	100	100	100	25	100	100	0	100	50	0	75	0
Day-6	100	100	100	100	25	100	50	0	100	0	0	75
Avg. Util%	100	100	100	75	75	75	50	50	50	25	25	25

Conclusion

Equal utilization of all the 3 compressor based on pressure demand

The scheduler reduces power consumption since compressors are only utilized based on demand.

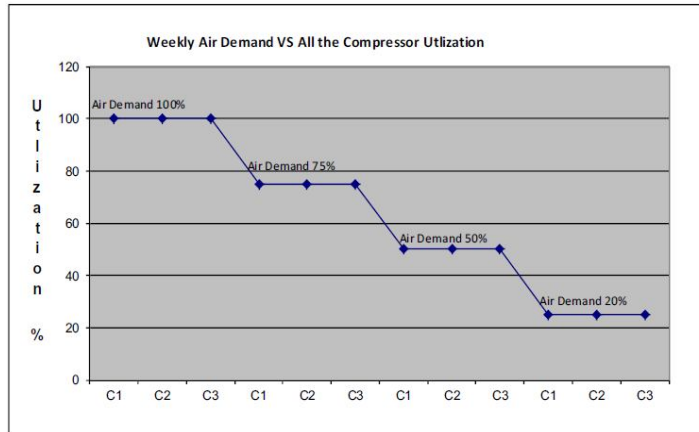

Neuron III Pressure schedule setup

- Step-1 Go to operator menu
- Step-2 Enter password "4545"
- Step-3 operator -> schedule
- Step-4 enable
- Step-5 set ON TIME
- Step-6 set OFF TIME
- Step-7 set load Pr.
- Step-8 set unload Pr.

7.12 Revision Details

Version	Date	Changes
1.0	25/02/15	Release
2.0	09/05/15	Updated corrections
3.0	30/06/17	Software features & CE/UL updated
3.1	01/03/18	Software version 2.07
3.2	01/12/18	Software version 2.08
3.3	11/03/19	Software version 2.09
3.4	05/07/19	Software version 2.09a
3.5	10/02/20	Software version 2.09b
3.6	10/07/20	Software version 2.09c

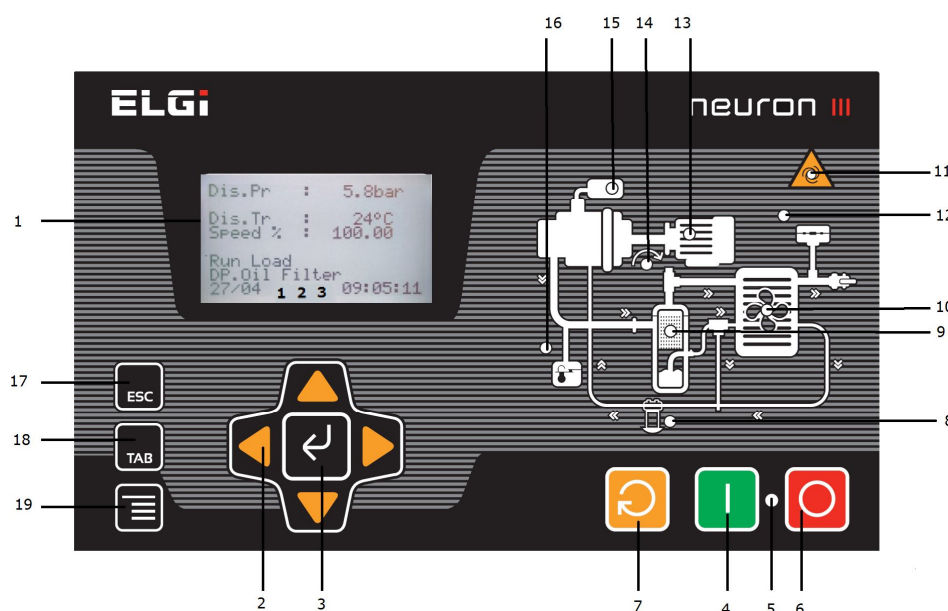

- 1 128x64 Graphical display
- 2 Navigation keys
- 3 Enter key
- 4 Start key
- 5 LED (green - start , red - stop/fault)
- 6 Stop key
- 7 Reset key
- 8 Oil filter change indication LED
- 9 Air oil separator change indication LED
- 10 Cooler fault LED
- 11 Auto mode enabled indication LED
- 12 High pressure fault LED
- 13 Main motor fault LED
- 14 Reverse rotation fault LED
- 15 Air filter change indication LED
- 16 High discharge temperature fault LED
- 17 Escape key
- 18 Tab key
- 19 Info key

MAIN SCREEN DISPLAY

- Package Discharge Pressure
- Discharge Temperature
- VFD Speed % on screen (if applicable)
- Machine Status like Run, Load, Unload, Standby etc.
- Warning Messages
- Date & Time
- Mode Information (see below)

Mode Information – 1, 2, 3

1. PS – Pressure Schedule Enabled / UL – Unload Mode Enabled
2. L – Local / R – Remote / D – DCS

MAIN SCREEN SHORTCUTS

Pressing the navigation keys while on the main menu allows user to read common settings.

►“RIGHT” - Live Analog Values

1. Live Differential Pressure (Displays only if Sump Pressure enabled)
2. Live Sump Pressure (Displays only if Sump Pressure enabled)
3. Live Pt1000 Temperature (Displays only if Dryer ON enabled)

▲ “UP” – Set Analog Values

1. Current Load Pressure
2. Current Unload Pressure
3. Current Start Sump Pressure (Displays only if Sump Pressure enabled)
4. Current Differential Pressure (Displays only if Sump Pressure enabled)

▼ “DOWN” – Today Report

1. Load and Stop Hours
2. Unload and Fault Hours
3. Run and Standby Hours

Compressor Status messages

Status	Description
Ready	Ready for start
Star	Motor running in star
Run	Motor running in delta
Run load	Compressor in load
Run unload	Compressor in unload
Stop busy	Stop sequence in progress
Emergency stop	Emergency stop push switch is ON
Start inhibit xx.x	During the start, if the sump pressure is higher than the set start sump pressure value, you will see this message. XX.X denotes the live sump pressure value. The compressor starts only if the sump pressure value goes below the set value.
Temperature inhibit ±XX	During the start, if the discharge temperature is lower than the set inhibit temperature value, you will see this message. ±XX denotes the live discharge temperature value. The compressor starts only if the discharge temperature value goes above the set value.
Start inhibit "seconds"	If sump pressure is not used (disabled) then the controller will ensure minimum 60 seconds delay between the stop and the start. Count stops if "STOP" key is pressed
Auto restart "seconds"	If compressor is in auto mode, the controller will ensure minimum delay (user set, e.g. 60 sec) between stop and start. count stops if "STOP" key is pressed
Start ack wait...	This message is displayed after a fault is cleared and waiting for user acknowledgement. By pressing "RESET" key user can acknowledge.
Standby	Compressor in standby

Compressor Warning messages

Warning	Description
DPAF	If DPAF Digital Input is Open and DPAF ON in factory setting
DPOF	If DPOF Digital Input is Open and DPOF ON in factory
Dryer Probe Failure	When Ch-4 analog sensor input fails
Dryer Off - Low DP warn	When Ch-4 Dew point temp. is less than Set value
High Dew Point	When Ch-4 Dew point temp. is greater than Set Value
High Differential Pressure	When the difference between Sump. Pressure and Discharge Pressure exceeds the Set Pressure. (Only in Sump Pr. Enabled condition)
Warn Temperature	When Discharge temp. exceeds the set warntemperature (Default is 105Deg C/Deg F)
Change Oil Filter	When service remaining Hr. reaches 0000 Hrs
Change Air Filter	When service remaining Hr. reaches 0000 Hrs
Change Oil	When service remaining Hr. reaches 0000 Hrs
Change Grease	When service remaining Hr. reaches 0000 Hrs
Change Separator	When service remaining Hr. reaches 0000 Hrs
Change Valve kit	When service remaining Hr. reaches 0000 Hrs
Dryer Off - IP Warn	If Dryer Digital Input is Open and dryer warn is selected in the input
Calibration error	When there is error in sensor calibration

Compressor Fault messages

Fault	Description
Pr. Probe failure	Discharge pressure sensor probe failure
Tr. Probe failure	Temperature sensor probe failure
Sump pr. probe failure	Sump pressure sensor probe failure, if sump pressure is enabled
HSP (AS)	Case 1: sump pressure is enabled
	If sump pressure exceeds the set high sump pressure value.
HSP (AD)	If discharge pressure exceeds the set high sump pressure value.
Cooler	If the cooler digital Input opens due to Cooler fault
Main motor overload/ VFD error	IF the MMOL digital input opens due to main motor over load. VFD error if VFD control is enabled.
Rev rot / Ph fail	If the rev rot input closes when motor running due to motor reverse rotation or Phase failure.
Trip temperature	If the discharge temperature exceeds the set trip temperature value.
Sump Pressure Not Developing	After the Start, The sump pressure should be at least 0.3 bar/4psi after star delay expires. If this is NOT achieved this Fault occurs , if sump pressure is enabled.
Power failure	If the mains supply is interrupted for more than 20 msec
Low voltage	If the mains supply voltage is less than the 75% of rated voltage. Compressor is tripped & All controller operation is halted until the mains supply Comes back to normal (at least 85% of the rated)
Dis. pressure Not developing	After the Load, The discharge pressure should be at least 0.5 bar/7psi in 5mins. If this is NOT achieved this fault occurs
Dryer IP trip	If dryer is enabled with trip, if dryer trip occurs, this fault message will be shown
Dryer low DP trip	When dew point temperature is less than set value.
Temperature not developing	If the discharge temperature not raised above the inhibit temperature before the set inhibit temperature time.
Winding temp. high/fail	It will trip the compressor based on SET value of MOTOR WINDING temperature/ sensor open

Menu Structure

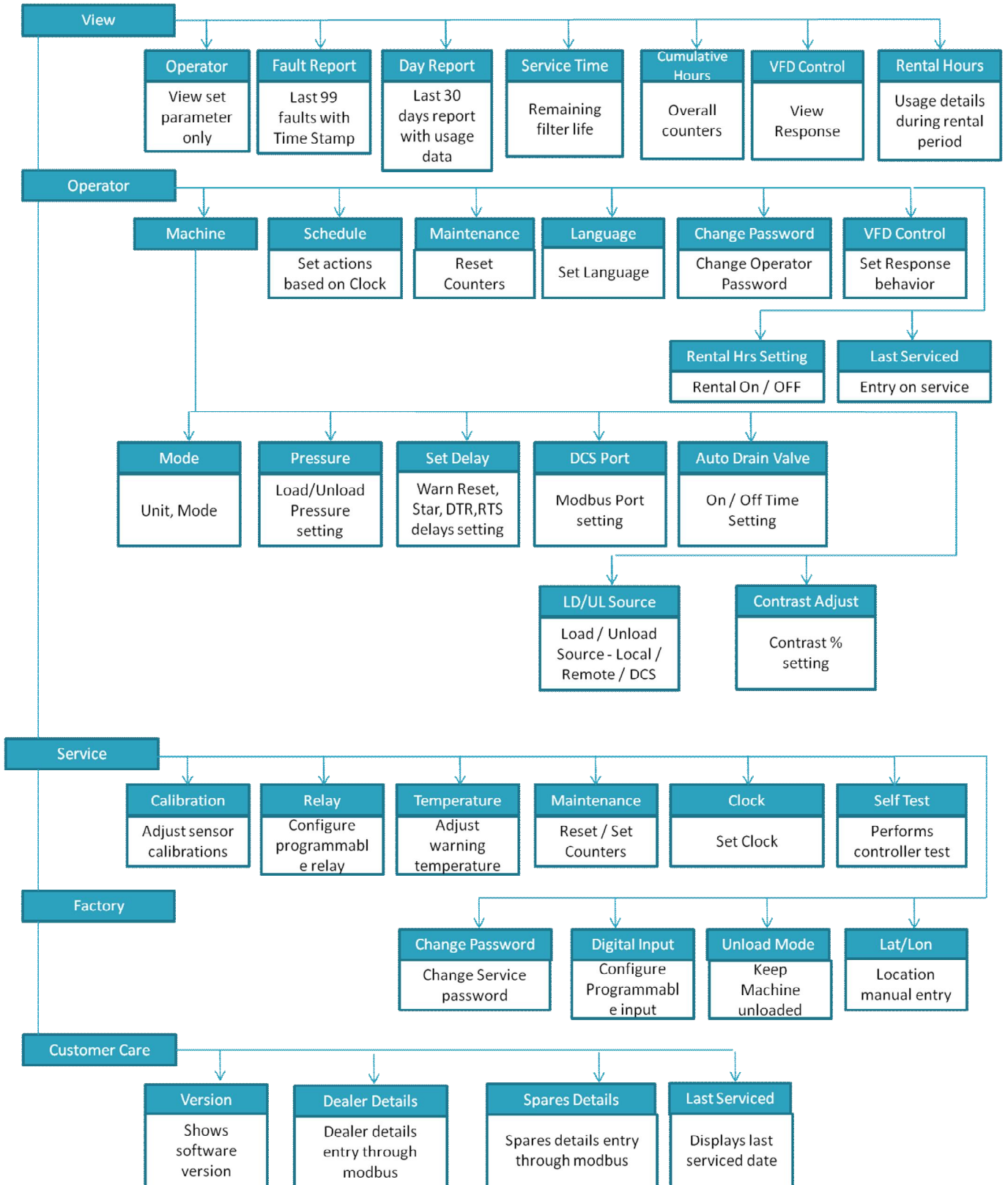



PARTS MANUAL

EG SERIES

ELECTRIC POWERED SCREW AIR COMPRESSOR
EG 11 to EG 22

8.0 Air Inlet system

[Ref : 015316778 —X017011] EG 18 & EG 18 V - 100.0, 125.0 psi.g; EG 22 & EG 22 V - 100.0, 125.0, 150.0 psi.g

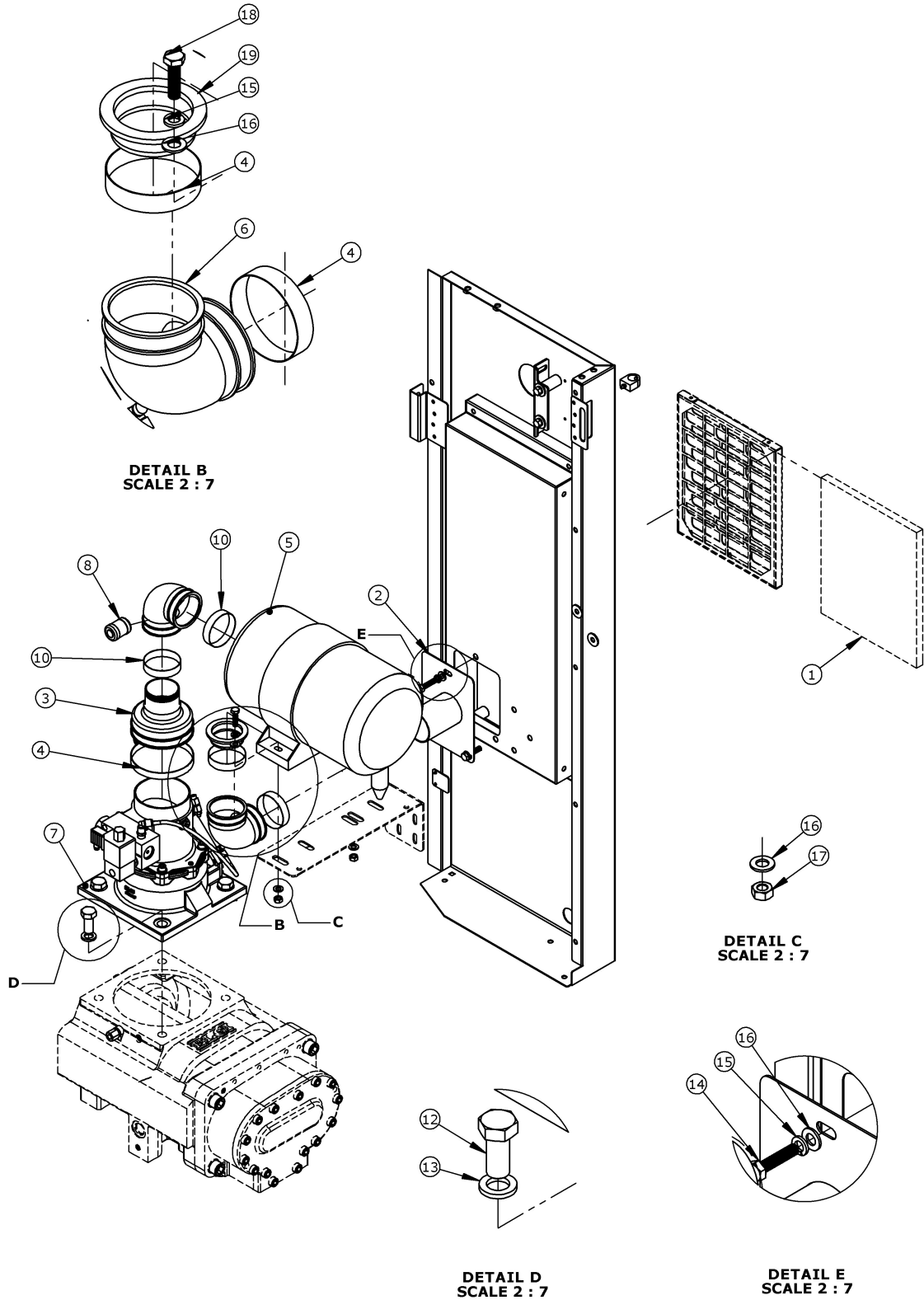

8.0 Air Inlet system

[Ref : 015316778 —X017011]

Sl. No.	Description	Qty.	Part Number
1	PRE FILTER	1	015400889
2	AIR FILTER ADAPTOR	1	015318043
3	RUBBER REDUCER	1	015317377
4	SS WORM CLAMP	4	B005000530003
5	AIR FILTER ASSY	1	B004700770002
6	RUBBER DUCT	1	015404122
7	INTAKE VALVE	1	A970012
8	SERVICE INDICATOR	1	B004700770017
9	TUBINGS 6MM	1.8	000920620
10	SS WORM CLAMP	1	B005000530005
11	QF ELBOW	1	000920624
12	SCR SOC HD M16X35	4	000996213
13	WASHER SPRING M16	4	000996116
14	BOLT HEX M8X25	3	000906116
15	WASHER SPRING M8	5	000996108
16	WASHER;PLATE M8	7	000996058
17	NUT;HEX;M8	2	000948008
18	BOLT HEX M8X40 8.8	2	000906119
19	RUBBER DUCT *	1	015403827
20	BULK HEAD CONNECTOR	1	B010500170002
21	NON RETURN VALVE	1	B004100170001
22	ADJ. SS ELBOW 3/8 BSP	2	B010506720013
23.1	BLOWDOWN HOSE	1	015404123
23.2	SCAVENGING PIPE	1	015320490
23.3	PULS LINE PIPE	1	015320491
24	CONNECTOR 1/4 BSP	1	B009606780009
25	1/8 BONDED SEAL WASHER	3	000959381
26	ORIFICE G1-8 DIA-1 M-F	1	015403984
27	1/8" BSP- DIA 6MM - ELBOW	1	B010505390017
28	ST ADAPTOR 1/8-1/8 BSP MALE	1	B010506360057
29	PLASTIC TUBE (BLUE)	1	000919226
30	ST FITTING	1	015403616

* Not applicable for this model

8.0 Air Inlet system

[Ref : 015316778 —X017011] EG 18 & EG 18 V - 100.0, 125.0 psi.g; EG 22 & EG 22 V - 100.0, 125.0, 150.0 psi.g

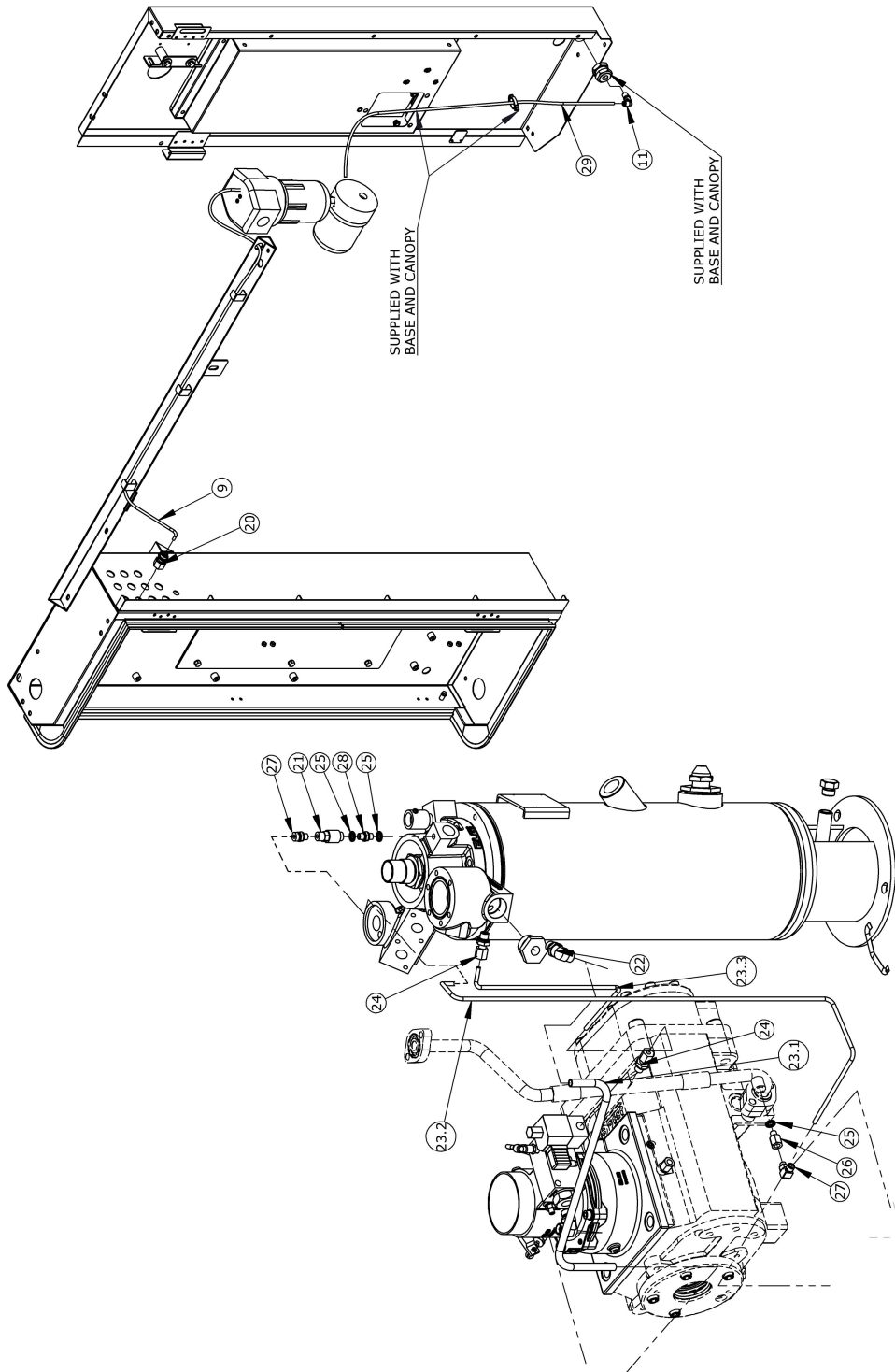

8.0 Air Inlet system

[Ref : 015316778 —X017011]

Sl. No.	Description	Qty.	Part Number
1	PRE FILTER	1	015400889
2	AIR FILTER ADAPTOR	1	015318043
3	RUBBER REDUCER	1	015317377
4	SS WORM CLAMP	4	B005000530003
5	AIR FILTER ASSY	1	B004700770002
6	RUBBER DUCT	1	015404122
7	INTAKE VALVE	1	A970012
8	SERVICE INDICATOR	1	B004700770017
9	TUBINGS 6MM	1.8	000920620
10	SS WORM CLAMP	1	B005000530005
11	QF ELBOW	1	000920624
12	SCR SOC HD M16X35	4	000996213
13	WASHER SPRING M16	4	000996116
14	BOLT HEX M8X25	3	000906116
15	WASHER SPRING M8	5	000996108
16	WASHER;PLATE M8	7	000996058
17	NUT;HEX;M8	2	000948008
18	BOLT HEX M8X40 8.8	2	000906119
19	RUBBER DUCT *	1	015403827
20	BULK HEAD CONNECTOR	1	B010500170002
21	NON RETURN VALVE	1	B004100170001
22	ADJ. SS ELBOW 3/8 BSP	2	B010506720013
23.1	BLOWDOWN HOSE	1	015404123
23.2	SCAVENGING PIPE	1	015320490
23.3	PULS LINE PIPE	1	015320491
24	CONNECTOR 1/4 BSP	1	B009606780009
25	1/8 BONDED SEAL WASHER	3	000959381
26	ORIFICE G1-8 DIA-1 M-F	1	015403984
27	1/8" BSP- DIA 6MM - ELBOW	1	B010505390017
28	ST ADAPTOR 1/8-1/8 BSP MALE	1	B010506360057
29	PLASTIC TUBE (BLUE)	1	000919226
30	ST FITTING	1	015403616

* Not applicable for this model

9.0 Drive system

[Ref : 015316744—X016997] EG 18 - 100.0, 125.0 psi.g

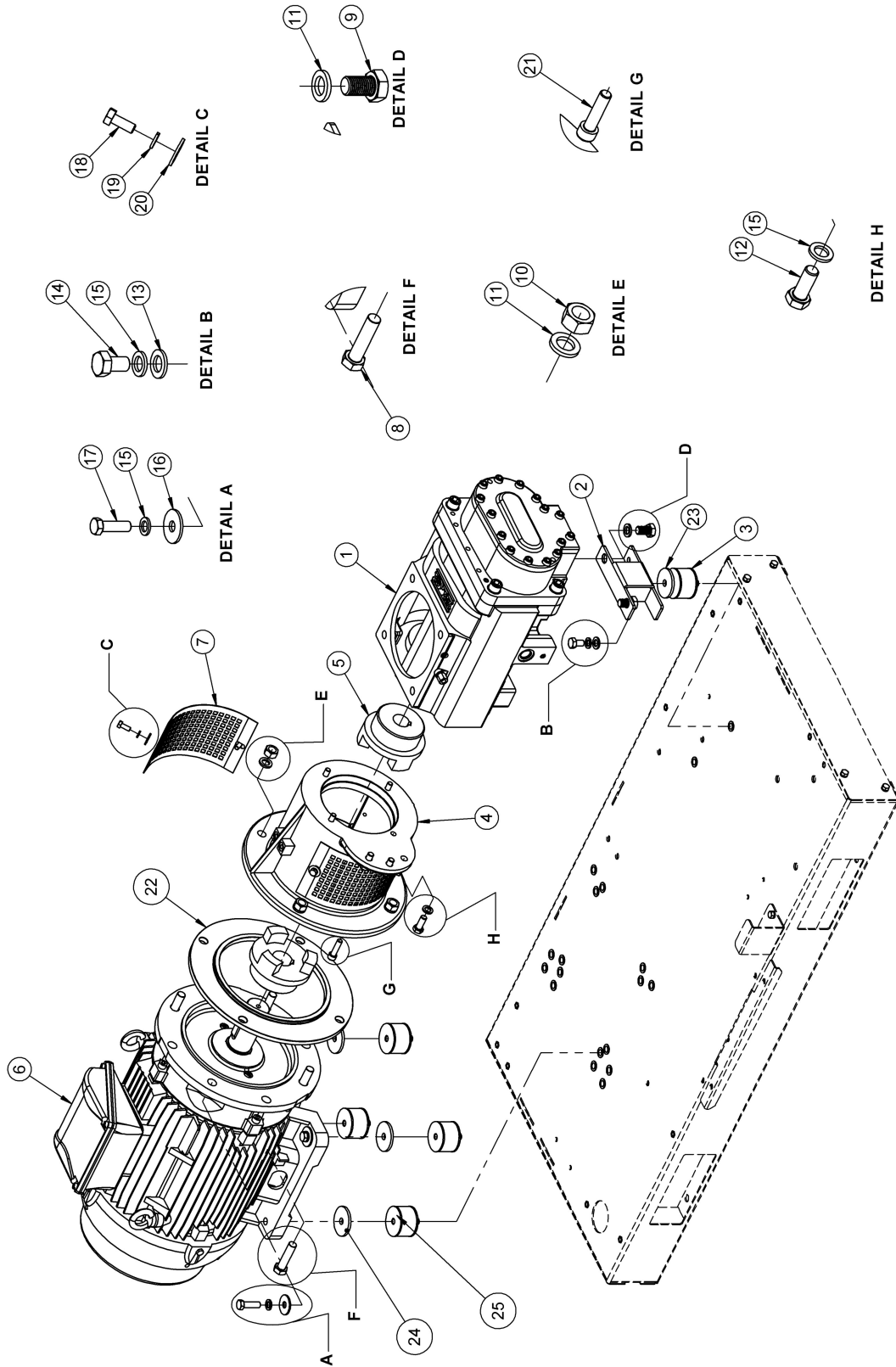

9.0 Drive system

[Ref : 015316744—X016997]

Sl. No.	Description	Qty.	Part Number
1	AIREND 100 psi	1	X990626
	AIREND 125 psi	1	X990686
2	AIR END SUPPORT	1	015313389
3	ANTI VIBRATION MOUNT	1	B001401300003
4	ADAPTOR RING	1	015305730
5	DRIVE COUPLING	1	B005405550018
6	MOTOR	1	B005106400007
7	COUPLING GUARD	2	990303610
8	BOLT HEX M16X65	4	000906219
9	BOLT HEX M16X25	2	000906211
10	NUT;HEX; M16;	4	000948016
11	WASHER SPRING M16	6	000996116
12	BOLT HEX M12X30	3	000906183
13	WASHER;PLATE;M12	1	000996060
14	BOLT HEX M12X25	1	000906182
15	WASHER SPRING M12	8	000996112
16	WASHER PLAIN M12	4	000996012
17	BOLT;HEX;M12x45	4	000906186
18	BOLT HEX M8X25	4	000906116
19	WASHER SPRING M8	4	000996108
20	WASHER;PLATE M8	4	000996058
21	SCR SOC HD M10X45	4	000983118
22	SPACER - ADAPTOR RING	1	015402508
23	SPACER - AVM	1	015404128
24	SPACER AVM	4	015404340
25	ANTI VIBRATION MOUNT	4	B001401300022

10.0 Discharge system

[Ref : 015316751—X017004] EG 18 - 100.0, 125.0 psi.g; EG 22 - 100.0, 125.0, 150.0 psi.g

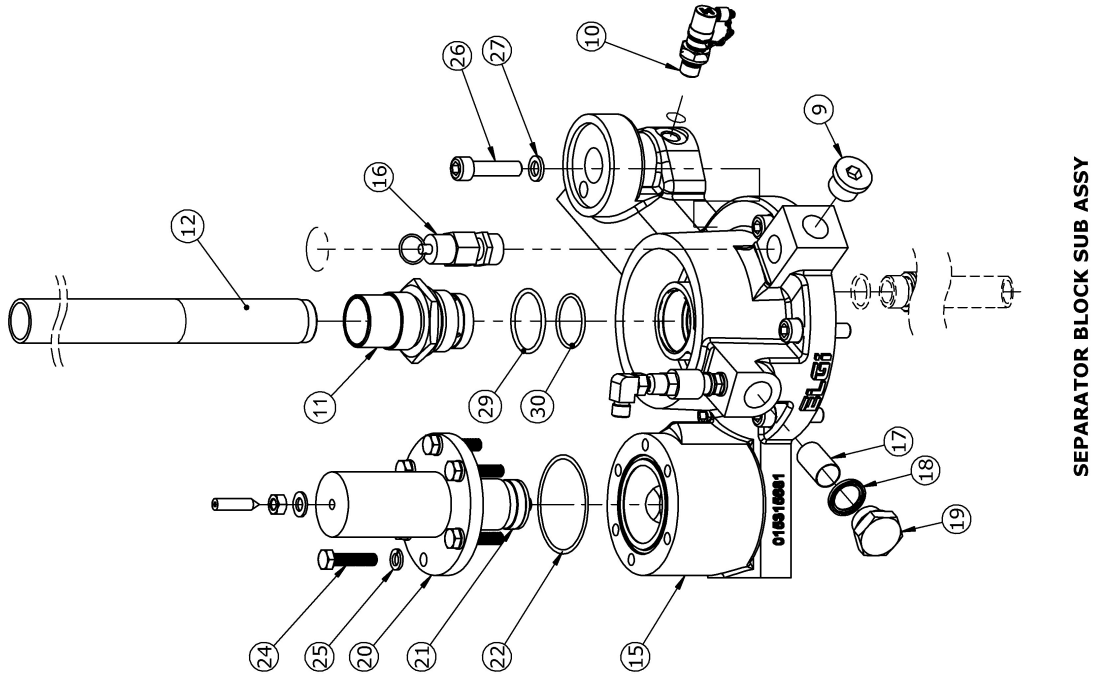

SEPARATOR BLOCK SUB ASSY

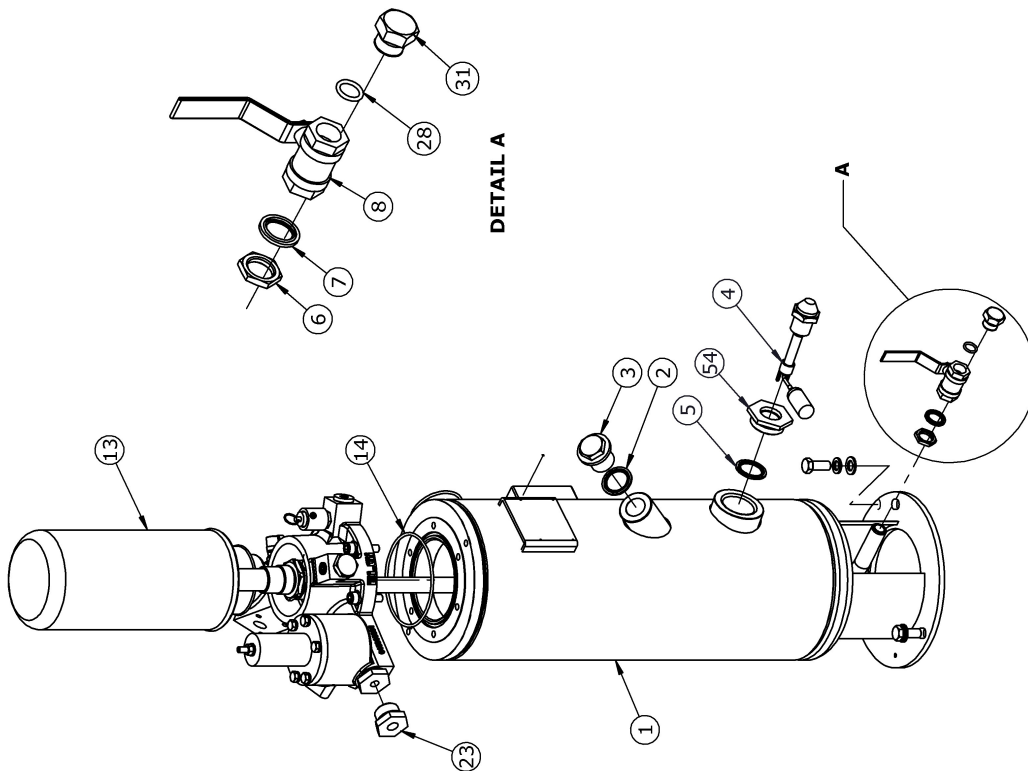

AOS TANK SUB ASSY

10.0 Discharge system

[Ref : 015316751—X017004]

Sl. No.	Description	Qty.	Part Number	Sl. No.	Description	Qty.	Part Number
1	AOS TANK	1	015318047	37	O-RING ID69.4 X 3.5	2	010453920
2	1" BONDED SEAL WASHER	1	000959439	38	DISCHARGE HOSE ASSY	1	015318049
3	OIL FILL PLUG	1	015402651	39	BOLT HEX M8X30	4	000906117
4	OIL SIGHT - FLOT TYPE	1	B010706790001	40	WASHER SPRING M8	8	000996108
5	1 1/2" BONDED SEAL WASHER	1	000959391	41	WASHER PLAIN M8	2	000996008
6	LOCK NUT 1/2"	1	020496120	42	WASHER	4	015404399
7	1/2" BONDED SEAL WASHER	1	000959387	43	WASHER SPRING M10	4	000996110
8	VALVE ASSY BALL 1/2"	1	B312717	44	BOLT HEX M10X30	4	000906145
9	CLOSURE PLUG G1/2"	1	B010506360004	45	WASHER;PLATE;M12	7	000996060
10	OIL SAMPLING VALVE 1/4"	1	B013206660001	46	WASHER SPRING M12	7	000996112
11	DOUBLE FITTING	1	015322216	47	BOLT HEX M12X35	4	000906184
12	SEPARATOR TUBE	1	015322217	48	BOLT HEX M12X30	3	000906183
13	AIR OIL SEPERATOR SPINON	1	B006700770010	49	MALE ST CONNECTOR 1/2" X 6MM	1	B009605390004
14	O-RING ID122.0 X 3.6	1	415400655	51	PLASTIC TUBING DIA6x1	1	000919226
15	SEPARATOR BLOCK BODY	1	015315681	52	QF ELBOW 1/4BSP-DIA 6	1	000920624
16	SAFETY VALVE	1	B012805340024	53	1"CONNECTOR	1	015317270
17	STRAINER MESH	1	B008806100003	54	REDUCER 1-1/2" TO 3/4"	1	035400662
18	M22 BONDED SEAL WASHER	1	000959436	55	CLOSER PLUG G1/4	1	B010506360010
19	PLUG STRAINER	1	015404020	56	QF CONN 1/4BSP-6	1	000920503
20*	MPV HOUSING	1	990402630	57	1/2 BONDED SEAL WASHER	1	000959387
21*	MPV SUB ASSY	1	A990223	58	AUTO DRAIN VALVE	1	B000306040013
22*	O-RING ID62.0 X 2.0	1	990402960	61	BOLT HEX M8x30	4	000906117
23	ADAPTOR 1BSP M - 3/8 BSP F	1	B010506720008	66	PLASTIC TUBING DIA 6x1	1.3mt	000919226
24	BOLT HEX M8X25	6	000906116	67	BULK HEAD CONNECTOR	1	B010500170002
25	WASHER SPRING M8	6	000996108	68	1/4 BONDED SEAL WASHER	1	000959385
26	SCR SOC HD M10X35	6	000983116	69	1/4" MALEX1/4" FEMALE VALVE	1	B003105390005
27	WASHER SPRING M10	6	000996110	* MPV ASSEMBLY (Set Of Sl. No: 20, 21, 22)		1	015322558
28	1/2" BONDED SEAL WASHER	1	000959387				
29	O-RING M42	1	990404850				
30	O-RING	2	015404365				
31	PLUG HEX 1/2"BSP	1	340401400				
32	O-RING ID32.9 X 3.5	3	015402685				
33	PIPE COOLER TO MOS	1	015315687				
34	MOISTURE SEPARATOR	1	B000306040014				
35	PIPE OUTLET	1	015321577				
36	COVER OUTLET	1	015404310				

10.0 Discharge system

[Ref : 015316751—X017004] EG 18 - 100.0, 125.0 psi.g; EG 22 - 100.0, 125.0, 150.0 psi.g

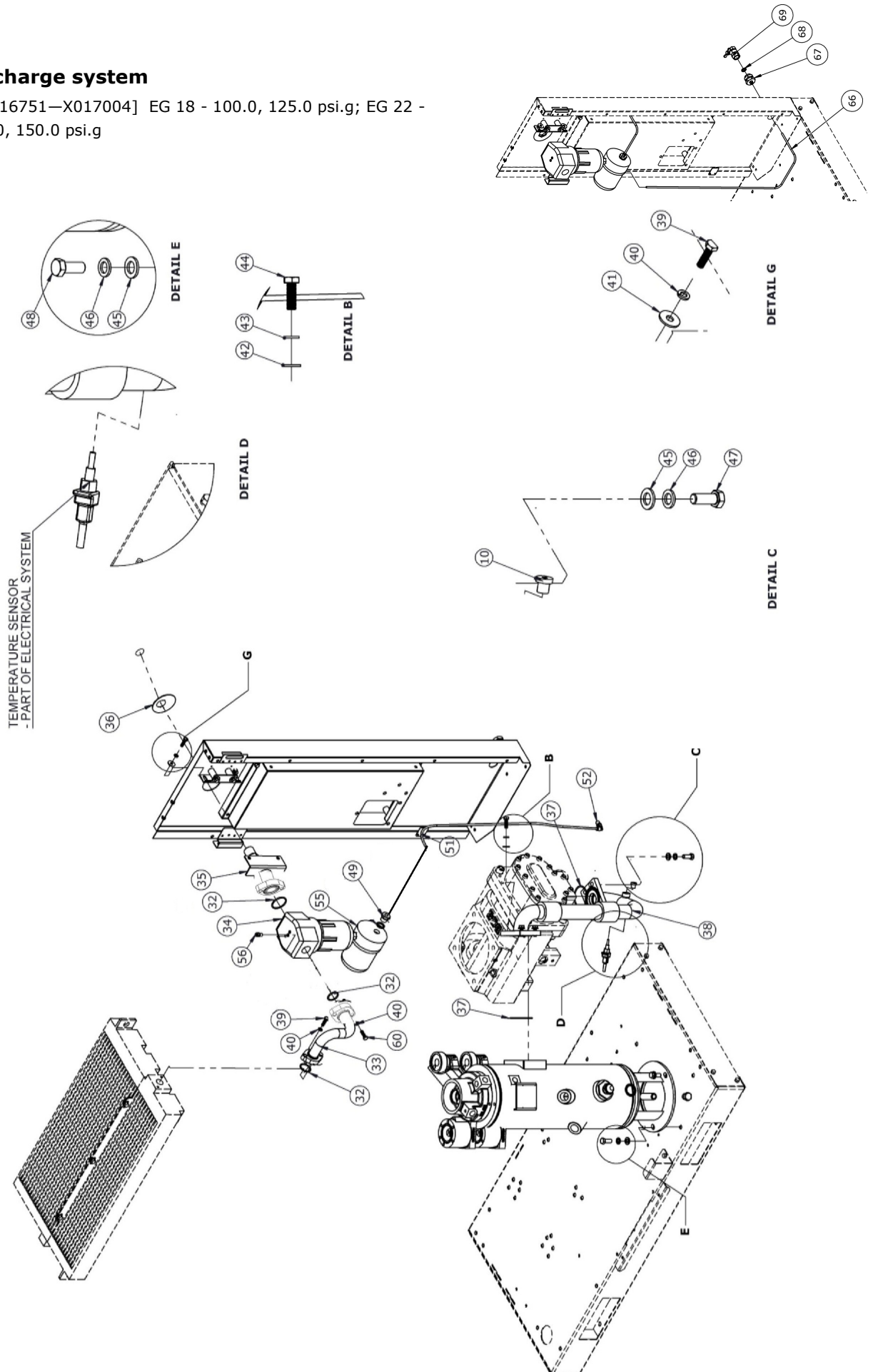

10.0 Discharge system

[Ref : 015316751—X017004]

Sl. No.	Description	Qty.	Part Number	Sl. No.	Description	Qty.	Part Number
1	AOS TANK	1	015318047	37	O-RING ID69.4 X 3.5	2	010453920
2	1" BONDED SEAL WASHER	1	000959439	38	DISCHARGE HOSE ASSY	1	015318049
3	OIL FILL PLUG	1	015402651	39	BOLT HEX M8X30	4	000906117
4	OIL SIGHT - FLOT TYPE	1	B010706790001	40	WASHER SPRING M8	8	000996108
5	1 1/2" BONDED SEAL WASHER	1	000959391	41	WASHER PLAIN M8	2	000996008
6	LOCK NUT 1/2"	1	020496120	42	WASHER	4	015404399
7	1/2" BONDED SEAL WASHER	1	000959387	43	WASHER SPRING M10	4	000996110
8	VALVE ASSY BALL 1/2"	1	B312717	44	BOLT HEX M10X30	4	000906145
9	CLOSURE PLUG G1/2"	1	B010506360004	45	WASHER;PLATE;M12	7	000996060
10	OIL SAMPLING VALVE 1/4"	1	B013206660001	46	WASHER SPRING M12	7	000996112
11	DOUBLE FITTING	1	015322216	47	BOLT HEX M12X35	4	000906184
12	SEPARATOR TUBE	1	015322217	48	BOLT HEX M12X30	3	000906183
13	AIR OIL SEPERATOR SPINON	1	B006700770010	49	MALE ST CONNECTOR 1/2" X 6MM	1	B009605390004
14	O-RING ID122.0 X 3.6	1	415400655	51	PLASTIC TUBING DIA6x1	1	000919226
15	SEPARATOR BLOCK BODY	1	015315681	52	QF ELBOW 1/4BSP-DIA 6	1	000920624
16	SAFETY VALVE	1	B012805340024	53	1"CONNECTOR	1	015317270
17	STRAINER MESH	1	B008806100003	54	REDUCER 1-1/2" TO 3/4"	1	035400662
18	M22 BONDED SEAL WASHER	1	000959436	55	CLOSER PLUG G1/4	1	B010506360010
19	PLUG STRAINER	1	015404020	56	QF CONN 1/4BSP-6	1	000920503
20*	MPV HOUSING	1	990402630	57	1/2 BONDED SEAL WASHER	1	000959387
21*	MPV SUB ASSY	1	A990223	58	AUTO DRAIN VALVE	1	B000306040013
22*	O-RING ID62.0 X 2.0	1	990402960	61	BOLT HEX M8x30	4	000906117
23	ADAPTOR 1BSP M - 3/8 BSP F	1	B010506720008	66	PLASTIC TUBING DIA 6x1	1.3mt	000919226
24	BOLT HEX M8X25	6	000906116	67	BULK HEAD CONNECTOR	1	B010500170002
25	WASHER SPRING M8	6	000996108	68	1/4 BONDED SEAL WASHER	1	000959385
26	SCR SOC HD M10X35	6	000983116	69	1/4" MALEX1/4" FEMALE VALVE	1	B003105390005
27	WASHER SPRING M10	6	000996110	* MPV ASSEMBLY (Set Of Sl. No: 20, 21, 22)		1	015322558
28	1/2" BONDED SEAL WASHER	1	000959387				
29	O-RING M42	1	990404850				
30	O-RING	2	015404365				
31	PLUG HEX 1/2"BSP	1	340401400				
32	O-RING ID32.9 X 3.5	3	015402685				
33	PIPE COOLER TO MOS	1	015315687				
34	MOISTURE SEPARATOR	1	B000306040014				
35	PIPE OUTLET	1	015321577				
36	COVER OUTLET	1	015404310				

11.0 Cooling system

[Ref : 015316757—X017010] EG 22

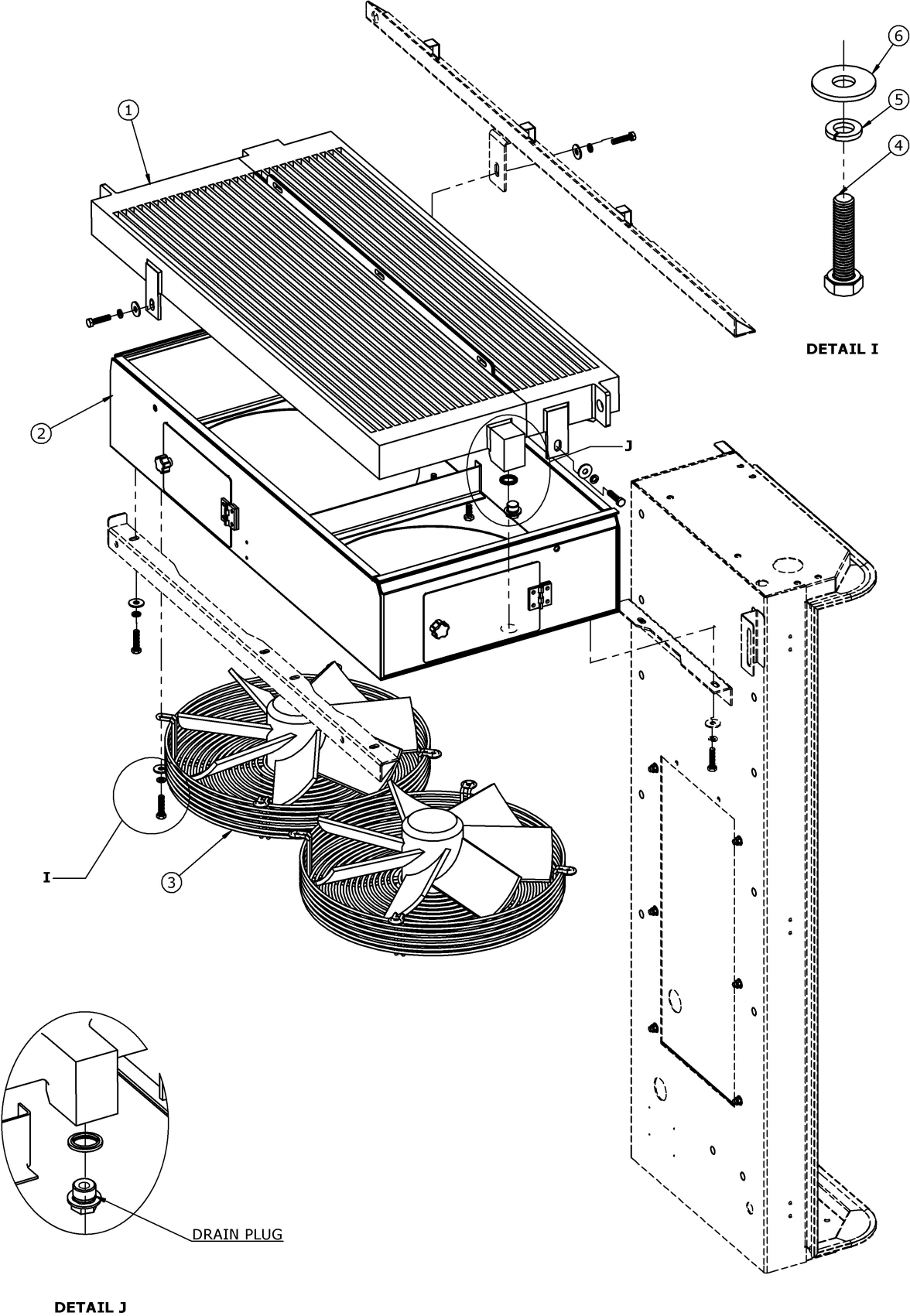

11.0 Cooling system

[Ref : 015316757—X017010]

Sl. No.	Description	Qty.	Part Number
1	OIL AND AFTER COOLER EG-22	1	015315678
2	COOLER SHROUD ASSY EG-22	1	015318039
3	PUSHER AXIAL FAN 350DIA,60HZ	2	B008106910003
4	BOLT HEX M8X25 8.8 ZYP 5-8M	15	000906116
5	WASHER SPRING M8 RECT ZYP	15	000996108
6	WASHER PLAIN M8 ZYP	15	000996008

12.0 Lubrication system

[Ref : 015316752—X0167005] EG 15

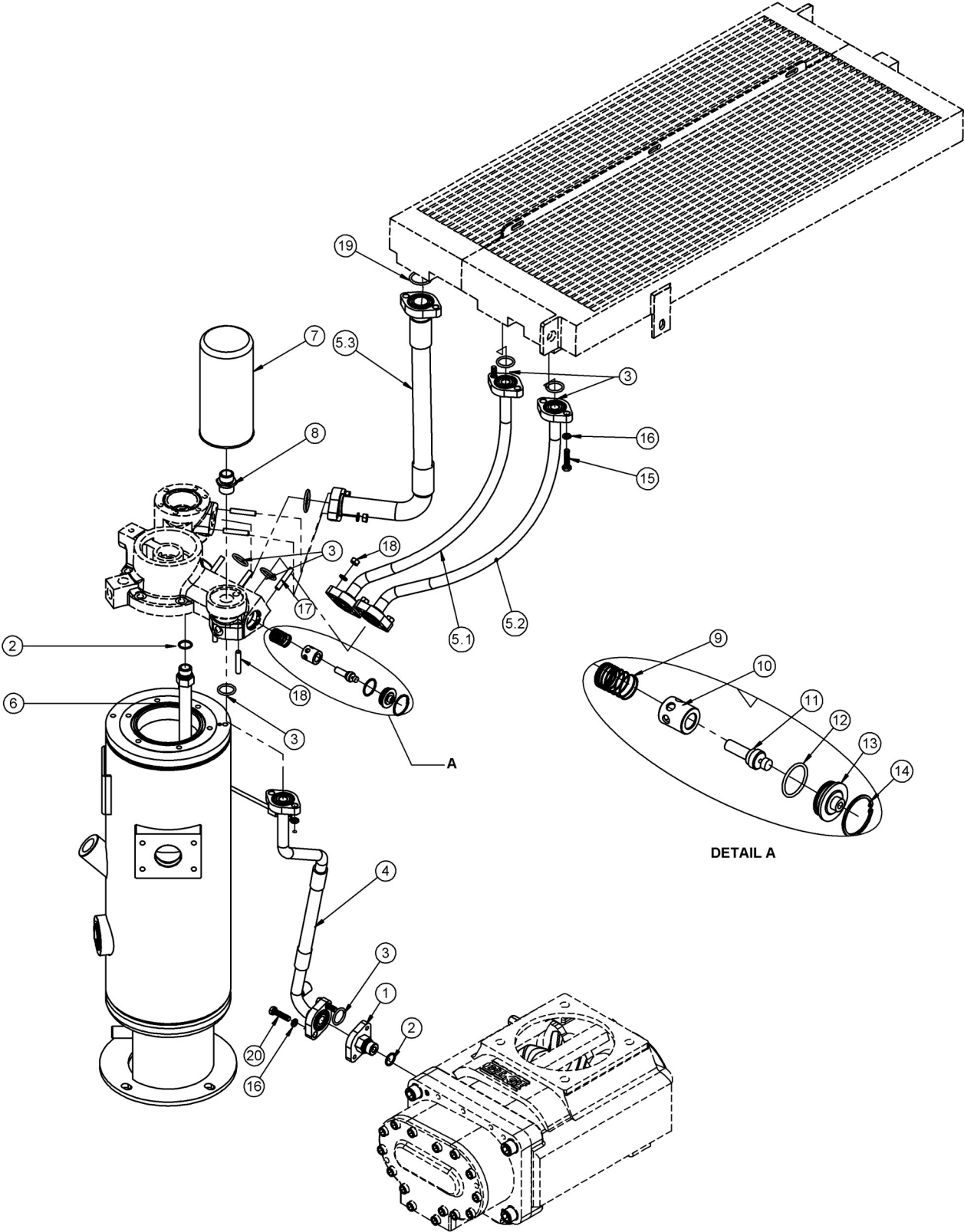

12.0 Lubrication system

[Ref : 015316752—X0167005]

Sl. No.	Description	Qty.	Part Number
1	PIPE ORIFICE	1	015315697
2	O-RING ID19.2 X 2.5	2	015402046
3	O-RING ID25.0 X 3.5	6	015403001
4	HOSE OIL INJECTION	1	015318015
5.1	HOSE TVB TO OC	1	015318017
5.2	HOSE OC TO TVB	1	015318016
5.3	HOSE MPV TO COOLER	1	015318018
6	PIPE OIL SUCTION EG-22	1	015315690
7	OIL FILTER ELEMENT-75 LPM	1	B004800770001
8	HEX ADAPTOR 1"UNFXM24	1	010440500
9	SPRING THERMAL	1	015401073
10	PISTON TVB EG22	1	015404024
11	THERMAL ELEMENT 65 Deg	1	B008706030003
12	O-RING ID27.6 X 2.4	1	015400890
13	THERMOSTATIC VALVE PLUG	1	015400874
14	CIRCLIP INTERNAL B37	1	000917237
15	BOLT HEX M8X25 8.8 ZYP 5-8M	4	000906116
16	WASHER SPRING M8 RECT ZYP	16	000996108
17	STUD M8	8	015404066
18	NUT;HEX;M8; ZYP	8	000948008
19	O-RING ID32.9 X 3.5	2	015402685
20	BOLT HEX M8X30 8.8 ZYP 5-8M	4	000906117

13.0 Base & canopy system

[Ref : 015316856—X017033] EG 22

PILLAR ASSEMBLY SEQUENCE

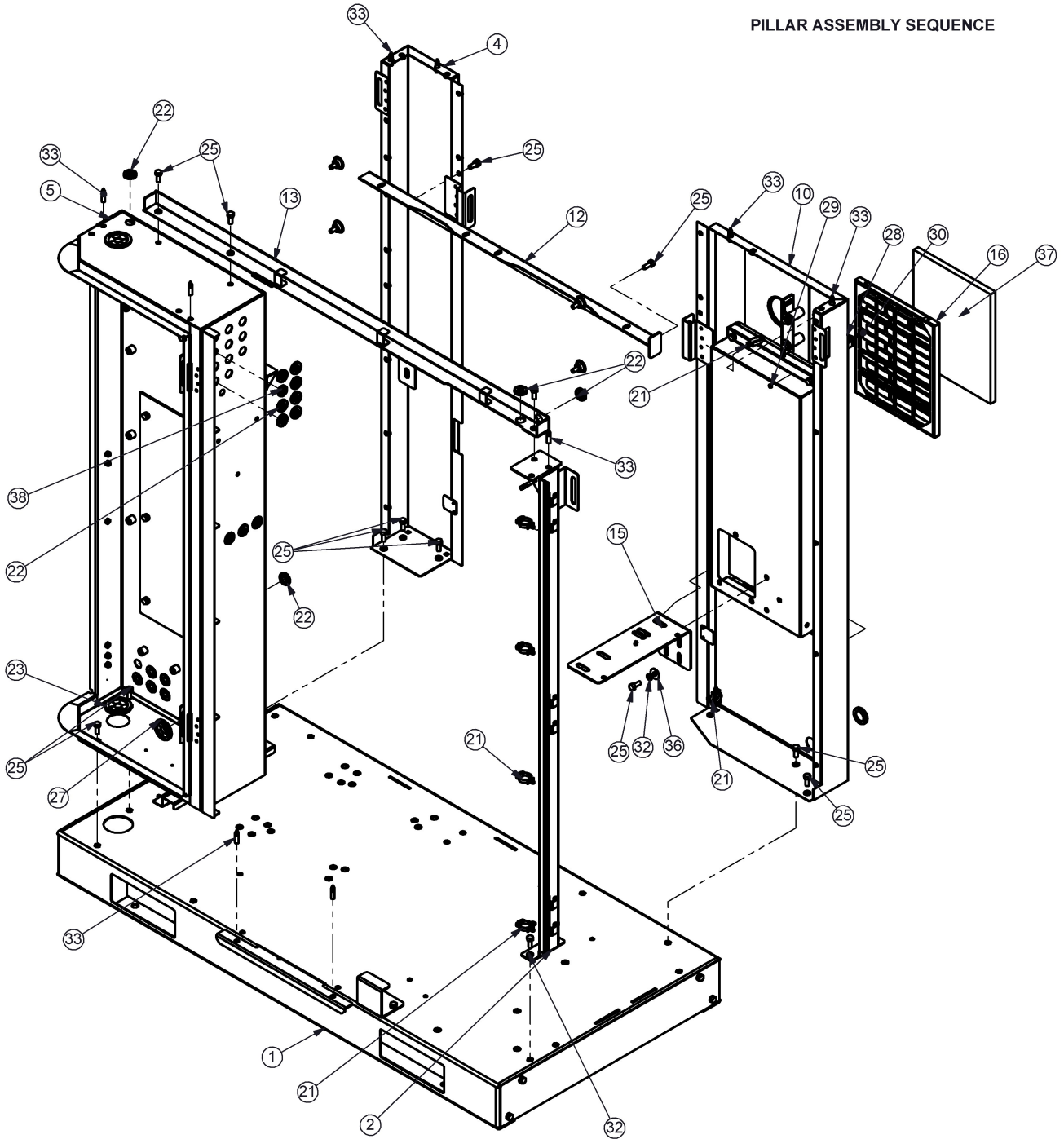

13.0 Base & canopy system

[Ref : 015316856—X017033]

Sl. No.	Description	Qty.	Part Number	Sl. No.	Description	Qty.	Part Number
1	BASE ASSEMBLY	1	015316783	39	REAR PANEL ASSEMBLY	1	015319130
2	TANK SIDE PILLAR ASSEMBLY	1	015315661	40	SCR SOC HD M8X16 10.9 ZYP	4	000983081
3	TOP ROOF PANEL ASSEMBLY	1	015318188	41	PLASTIC BUSH	4	015403244
4	MOTOR SIDE PILLAR ASSEMBLY	1	015315663	42	PRE FILTER -SS WIRE MESH	3	015320855
5	CONTROL PANEL ASSEMBLY	1	015315664				
6	CONTROL PANEL DOOR ASSY	1	015315675				
7	SERVICE DOOR ASSEMBLY	1	015315676				
8	PANEL ASSY LH	1	015315667				
9	PANEL ASSY RH	1	015315668				
10	DISCHARGE SIDE PILLAR ASSEMBLY	1	015318189				
11	REAR PANEL FIXED	1	015319131				
12	COOLER SUPPORT MEMBER	1	015315671				
13	CROSS-MEMBER FRONT	1	015318190				
14	FRONT PANEL ASSEMBLY	1	015316784				
15	AIR-FILTER BRACKET ASSY.	1	015318191				
16	CATRIDGE - PRE FILTER	2	015314902				
17	CONNECTOR ASSEMBLY - G¼	1	015312907				
18	HINGE MALE	6	B011604790005				
19	LOCK	12	B15204790005				
20	KEY	1	B15204790004				
21	WIRE GUIDE	12	008985060				
22	GROMMET DIA 20	20	01531068B				
23	GROMMET DIA 51	2	01531068F				
24	COUNTER SUNK SCREW M6X16	12	-				
25	HEX BOLT M8X20	19	-				
26	M8 PLASTIC PLUG	4	-				
27	GROMMET DIA 41	1	01531068E				
28	KEY HOLDER	1	015403237				
29	HEX NUT - M4	1	-				
30	SLOTTED CHEESE SCREW - M4 X 16	1	-				
31	GROMMET ID -31 MM	1	01531068D				
32	WASHER SPRING M8	19					
33	GUIDE PIN	9	015404034				
34	BOLT HEX SOC.HEAD M8 x 50	7	-				
35	NYLOC NUT - M6	12	-				
36	M8 PLAIN WASHER	2	-				
37	PRE FILTER	2	015400889				
38	GROMMET DIA 17	1	-				

13.0 Base & canopy system

[Ref : 015316856—X017033] EG 22

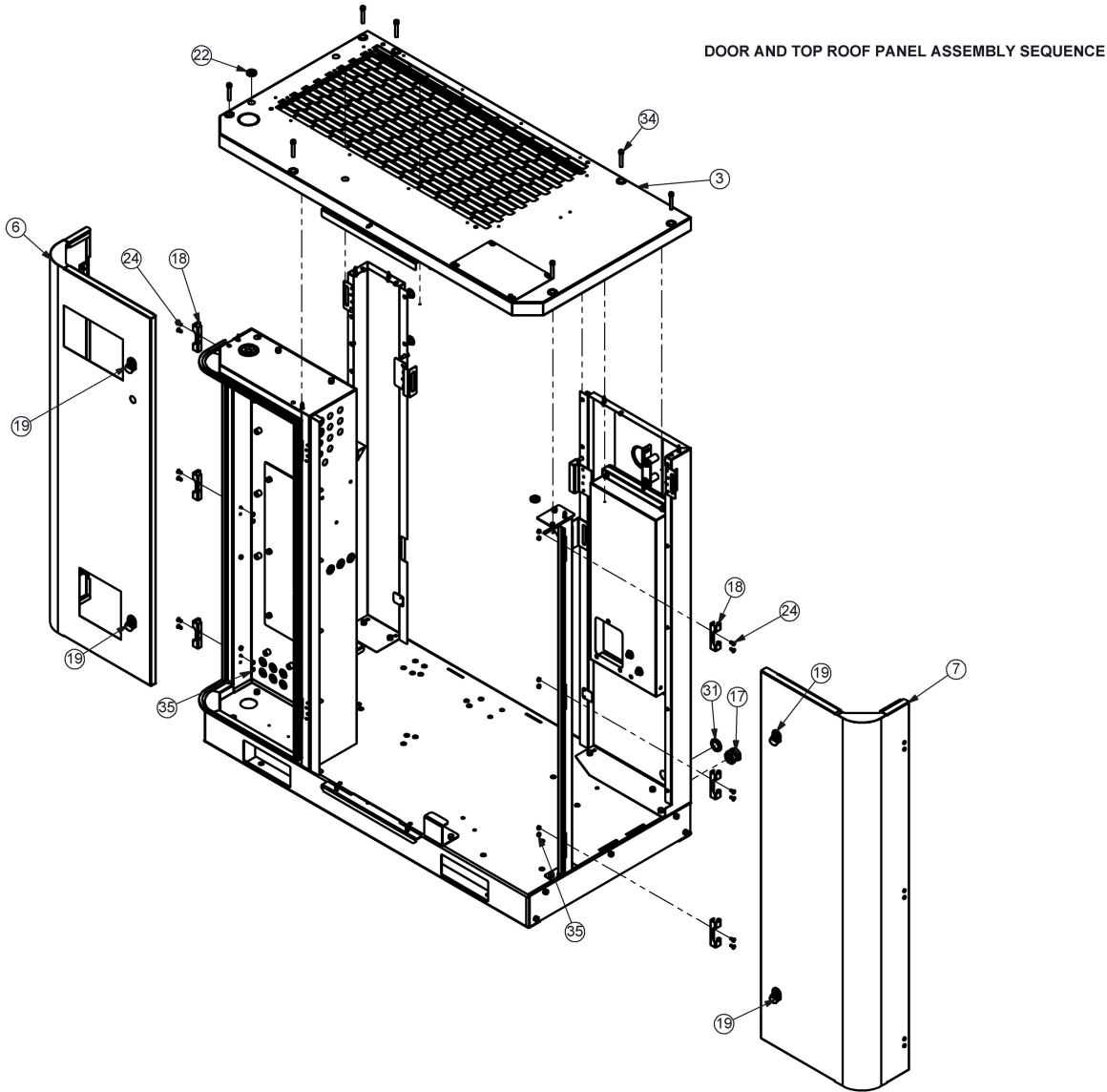

13.0 Base & canopy system

[Ref : 015316856—X017033]

Sl. No.	Description	Qty.	Part Number	Sl. No.	Description	Qty.	Part Number
1	BASE ASSEMBLY	1	015316783	39	REAR PANEL ASSEMBLY	1	015319130
2	TANK SIDE PILLAR ASSEMBLY	1	015315661	40	SCR SOC HD M8X16 10.9 ZYP	4	000983081
3	TOP ROOF PANEL ASSEMBLY	1	015318188	41	PLASTIC BUSH	4	015403244
4	MOTOR SIDE PILLAR ASSEMBLY	1	015315663	42	PRE FILTER -SS WIRE MESH	3	015320855
5	CONTROL PANEL ASSEMBLY	1	015315664				
6	CONTROL PANEL DOOR ASSY	1	015315675				
7	SERVICE DOOR ASSEMBLY	1	015315676				
8	PANEL ASSY LH	1	015315667				
9	PANEL ASSY RH	1	015315668				
10	DISCHARGE SIDE PILLAR ASSEMBLY	1	015318189				
11	REAR PANEL FIXED	1	015319131				
12	COOLER SUPPORT MEMBER	1	015315671				
13	CROSS-MEMBER FRONT	1	015318190				
14	FRONT PANEL ASSEMBLY	1	015316784				
15	AIR-FILTER BRACKET ASSY.	1	015318191				
16	CATRIDGE - PRE FILTER	2	015314902				
17	CONNECTOR ASSEMBLY - G¼	1	015312907				
18	HINGE MALE	6	B011604790005				
19	LOCK	12	B15204790005				
20	KEY	1	B15204790004				
21	WIRE GUIDE	12	008985060				
22	GROMMET DIA 20	20	01531068B				
23	GROMMET DIA 51	2	01531068F				
24	COUNTER SUNK SCREW M6X16	12	-				
25	HEX BOLT M8X20	19	-				
26	M8 PLASTIC PLUG	4	-				
27	GROMMET DIA 41	1	01531068E				
28	KEY HOLDER	1	015403237				
29	HEX NUT - M4	1	-				
30	SLOTTED CHEESE SCREW - M4 X 16	1	-				
31	GROMMET ID -31 MM	1	01531068D				
32	WASHER SPRING M8	19					
33	GUIDE PIN	9	015404034				
34	BOLT HEX SOC.HEAD M8 x 50	7	-				
35	NYLOC NUT - M6	12	-				
36	M8 PLAIN WASHER	2	-				
37	PRE FILTER	2	015400889				
38	GROMMET DIA 17	1	-				

13.0 Base & canopy system

[Ref : 015316856—X017033] EG 22

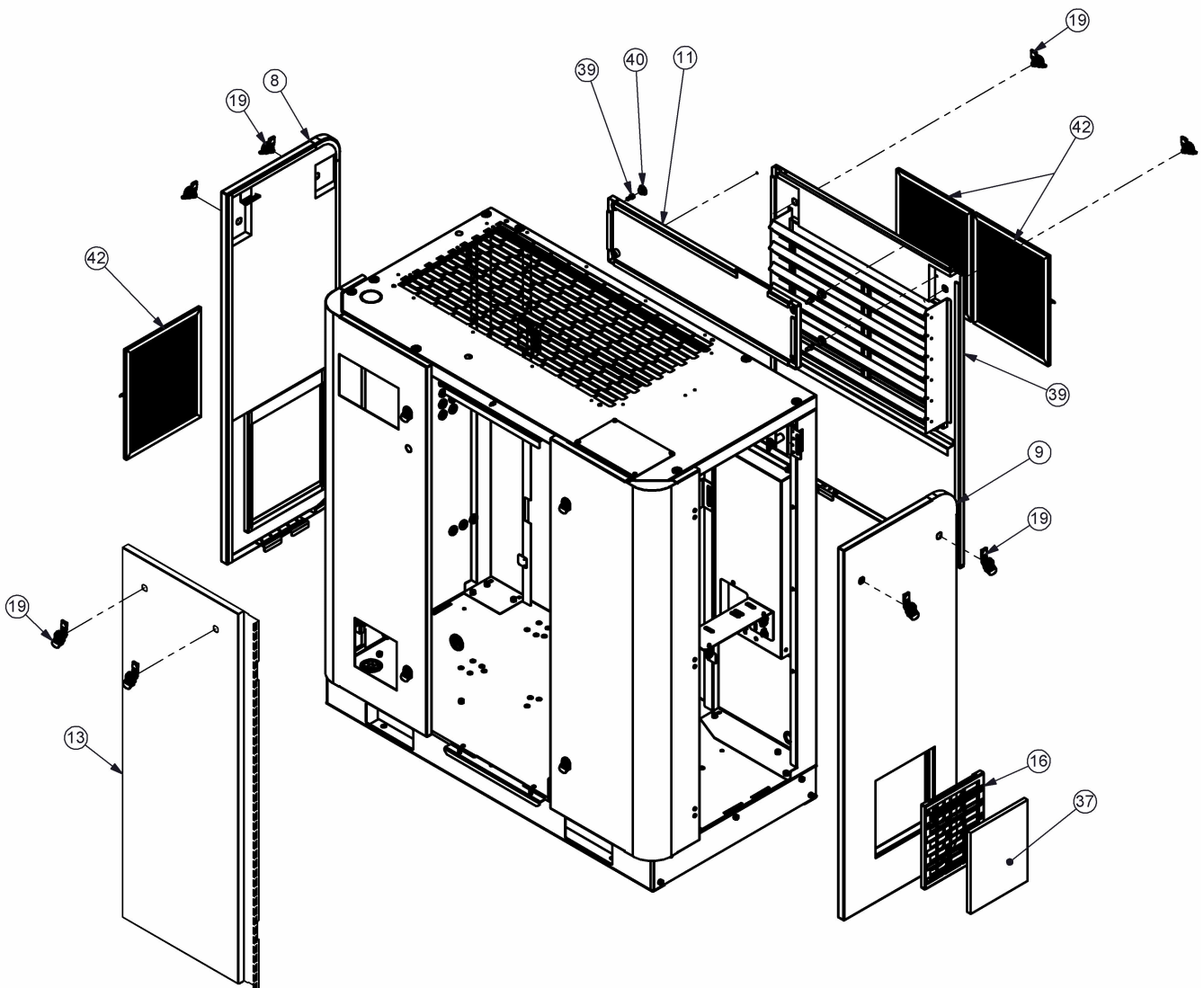

13.0 Base & canopy system

[Ref : 015316856—X017033]

Sl. No.	Description	Qty.	Part Number	Sl. No.	Description	Qty.	Part Number
1	BASE ASSEMBLY	1	015316783	39	REAR PANEL ASSEMBLY	1	015319130
2	TANK SIDE PILLAR ASSEMBLY	1	015315661	40	SCR SOC HD M8X16 10.9 ZYP	4	000983081
3	TOP ROOF PANEL ASSEMBLY	1	015318188	41	PLASTIC BUSH	4	015403244
4	MOTOR SIDE PILLAR ASSEMBLY	1	015315663	42	PRE FILTER -SS WIRE MESH	3	015320855
5	CONTROL PANEL ASSEMBLY	1	015315664				
6	CONTROL PANEL DOOR ASSY	1	015315675				
7	SERVICE DOOR ASSEMBLY	1	015315676				
8	PANEL ASSY LH	1	015315667				
9	PANEL ASSY RH	1	015315668				
10	DISCHARGE SIDE PILLAR ASSEMBLY	1	015318189				
11	REAR PANEL FIXED	1	015319131				
12	COOLER SUPPORT MEMBER	1	015315671				
13	CROSS-MEMBER FRONT	1	015318190				
14	FRONT PANEL ASSEMBLY	1	015316784				
15	AIR-FILTER BRACKET ASSY.	1	015318191				
16	CATRIDGE - PRE FILTER	2	015314902				
17	CONNECTOR ASSEMBLY - G¼	1	015312907				
18	HINGE MALE	6	B011604790005				
19	LOCK	12	B15204790005				
20	KEY	1	B15204790004				
21	WIRE GUIDE	12	008985060				
22	GROMMET DIA 20	20	01531068B				
23	GROMMET DIA 51	2	01531068F				
24	COUNTER SUNK SCREW M6X16	12	-				
25	HEX BOLT M8X20	19	-				
26	M8 PLASTIC PLUG	4	-				
27	GROMMET DIA 41	1	01531068E				
28	KEY HOLDER	1	015403237				
29	HEX NUT - M4	1	-				
30	SLOTTED CHEESE SCREW - M4 X 16	1	-				
31	GROMMET ID -31 MM	1	01531068D				
32	WASHER SPRING M8	19					
33	GUIDE PIN	9	015404034				
34	BOLT HEX SOC.HEAD M8 x 50	7	-				
35	NYLOC NUT - M6	12	-				
36	M8 PLAIN WASHER	2	-				
37	PRE FILTER	2	015400889				
38	GROMMET DIA 17	1	-				

RECOMMENDED SPARES

50Hz models

EG 11 - 7, EG 11 - 8, EG 11 - 9.5, EG 11 - 12.5; EG 15 - 9.5, EG 15 - 12.5; EG 18 - 12.5; EG 22 - 12.5

60Hz models

EG 11 - 100, EG 11 - 125, EG 11 - 150, EG 11 - 175; EG 15 - 100, EG 15 - 125, EG 15 - 150, EG 15 - 175; EG 18 - 150, EG 18 - 175; EG 22 - 175

A) PERIODIC MAINTENANCE KITS

1) Consumables Kit upto 8000 Hours - * Part Number 012475679

S. No	Description	Part Number	Qty.
1	Air filter element	B005700770004	2
2	Oil filter element-75 LPM	B004800770001	4
3	Air oil separator spin on	B006700770010	1
4	Suction pre filter	015400889	2

* Consists of all consumables required from commissioning upto 8000 hours of operation for machines with UT synthetic oil

2) 8000 Hours Service Kit - ** Part Number 012485144

S. No	Description	Part Number	Qty.
1	Air filter element	B005700770004	1
2	Oil filter element-75 LPM	B004800770001	1
3	Air oil separator spin on	B006700770010	1
4	Suction pre filter	015400889	1

** One time service kit consisting of all consumables required at 8000 hours (UT synthetic oil) / 4000 hours (ELGi Airlube XD)

3) Valve Kit - Part number 012485146

S. No	Description	Part Number	Qty.
1	Intake valve kit EIV 102	972300040	1
2	BDV valve assembly EIV 102	972300080	1
3	Solenoid valve NC,24V,50/60Hz	B007300990017	1
4	Minimum pressure valve kit - EN102	A990293	1
5	Actuator kit EIV 102	972300060	1
6	Auto drain valve	B000306040013	1

4) Tube and Fittings Kit - Part number 012485143

S. No	Description	Part Number	Qty.
1	Quick fittings CONN 1/4BSP-6	000920504	2
2	Tubing DIA.6x1	000919226	1 m
3	QF elbow 1/4BSP-DIA 6	000920624	4
4	Tubings 6MM	000920620	2.15 m

5) Blow down adjustment kit EIV102 972300110

S. No	Description	Part Number	Qty.
1	Tamper cap EIV	970300680	1
2	Screw grub hex soc head M8X40	970400370	1
3	Nut hex M8 ZYP	000948008	1

6) Drive Coupling Element

S. No	Description	Part Number	Qty.
1	Drive coupling element	B011201170003	1

7) Safety Valve

S. No	Description	Part Number	Qty.
1	Safety valve	B008401880003	1

8) Anti Vibration Mount

S. No	Description	Part Number	Qty.
1	Anti vibration mount	B001401300022	4
2	Anti vibration mount	B001401300003	1

9) Thermal Valve Kit

S. No	Description	Part Number	Qty.
1	Thermal valve kit 65 deg C (C & CD)	012485140	
1.1	Spring thermal	015401073	1
1.2	Thermal element 65 Deg	B008706030003	1
1.3	O-Ring ID27.6 X 2.4	015400890	1
1.4	Circlip internal B37	000917237	1
2	Thermal valve kit 75 deg C (CV & CDV)	012485141	
2.1	Spring thermal	015401073	1
2.2	Thermal element 75 Deg	B008706030008	1
2.3	O-Ring ID27.6 X 2.4	015400890	1
2.4	Circlip internal B37	000917237	1

B) OTHER MAINTENANCE KITS

S. No	Description	Part Number	Qty.
1	O-Ring Kit	012479659	
1.1	1/8 BSP Bonded seal washer	000959381	3
1.2	1/2 BSP Bonded seal washer	000959387	3
1.3	M22 Bonded seal washer	000959436	1
1.4	3/4BSP Bonded seal washer	000959438	1
1.5	O-Ring ID27.6 X 2.4	015400890	1
1.6	O-Ring ID19.2 X 2.5	015402046	2
1.7	O-Ring ID32.9 X 3.5	015402685	5
1.8	O-Ring ID25.0 X 3.5	015403001	6
1.9	O-Ring ID37.5 X 3.0	035400026	3
1.10	O-Ring ID122.0 X 3.6	415400655	1
1.11	O-Ring ID62.0 X 2.0	990402960	1
1.12	O-Ring ID56.7 X 3.5	035400187	1
1.13	O-Ring ID60.0 X 3.6	415400685	1
1.14	O-Ring ID32.8 X 2.3	990403438	1
1.15	O-Ring_M42 ISO	990404850	1

S. No	Description	Part Number	Qty.
2	SS Tube and fittings kit	012400662	
2.1	Pipe set EG-15	015320509	1
2.2	PMS coupling 1/4 BSP X 6MM	B009606780009	2
2.3	ST Fitting 1/8 TO 6MM OD	015403616	2
2.4	ADJ. SS Elbow 1/4 BSP X 8 MM	B010506720006	2

C) Hose kits

S. No	Description	Part Number	Qty.
1	MPV to cooler Hose kit	012479599	
1.1	Hose MPV TO AC EG-22	015318018	1
1.2	O-Ring ID32.9 X 3.5	015402685	2
2	Hose oil injection kit-11KW	012479609	
2.1	Hose Oil injection EG-11	015318014	1
2.2	O-Ring ID25.0 X 3.5	015403001	2
3	Hose tank to cooler kit	012479629	
3.1	Hose TVB TO OC EG-22	015318017	1
3.2	O-Ring ID25.0 X 3.5	015403001	2
4	Hose cooler to tank kit	012479639	
4.1	Hose OC TO TVB EG-22	015318016	1
4.2	O-Ring ID25.0 X 3.5	015403001	2

D) 8000 hours kit - Part Number 012400672

S. No	Description	Part Number	Qty.
1	One time consumable kit	012485144	1
2	8000 hrs valve kit	012485146	1
3	Drive coupling element	B011201170003	1
4	NRV	B004100170001	1
5	Safety valve	B008401880003	1
6	Strainer, return line	B008806100003	1
7	Tube and fittings kit	012485143	1

50Hz models

EG 15 - 7, EG 15 - 8; EG 18 - 7, EG 18 - 8, EG 18 - 9.5; EG 22 - 7, EG 22 - 8, EG 22 - 9.5

60Hz models

EG 18 - 100, EG 18 - 125; EG 22 - 100, EG 22 - 125, EG 22 - 150

A) PERIODIC MAINTENANCE KITS

1) Consumables Kit upto 8000 Hours 159 -* Part Number 012475689

S. No	Description	Part Number	Qty.
1	Air filter element	B005700770005	2
2	Oil filter element-75 LPM	B004800770001	4
3	Air oil separator spin on	B006700770010	1
4	Suction pre filter	015400889	2

* Consists of all consumables required from commissioning upto 8000 hours of operation for machines with UT synthetic oil

2) 8000 Hours Service Kit 159 - ** Part Number 012485145

S. No	Description	Part Number	Qty.
1	Air filter element	B005700770005	1
2	Oil filter element-75 LPM	B004800770001	1
3	Air oil separator spin on	B006700770010	1
4	Suction pre filter	015400889	1

** One time service kit consisting of all consumables required at 8000 hours (UT synthetic oil) / 4000 hours (ELGi Airlube XD)

3) Valve Kit 159 - Part number - 012400646

S. No	Description	Part Number	Qty.
1	Intake valve kit EIV 159	972300090	1
2	BDV assembly kit EIV159	972300030	1
3	Solenoid valve NC,24V,50/60Hz	B007300990017	1
4	Minimum pressure valve kit - EN102	A990293	1
5	Actuator kit EIV 159	972300070	1
6	Auto drain valve	B000306040013	1
7	Plug auto drain valve	B010501880008	1

4) Tube and Fittings Kit - Part number 012485142

S. No	Description	Part Number	Qty.
1	Quick fittings CONN 1/4BSP-6	000920504	2
2	Tubing DIA.6x1	000919226	1 m
3	QF elbow 1/4BSP-DIA 6	000920624	4
4	Tubings 6MM	000920620	2.15m
5	Union Elbow Dia 10	B010501880007	1
6	Tubings 10 MM	000919244	0.12 m
7	Quick fittings CONN 3/8 BSP 10	000920509	1
8	Quick fittings elbow 3/8 BSP 10	000920609	1

5) Blow down adjustment kit EIV159 - 972300100

S. No	Description	Part Number	Qty.
1	Tamper cap MPV	970300510	1
2	M10 hex socket grub screw	970400160	1
3	Nut Hex M10 X 1 ZBP	000948013	1

6) Drive Coupling Element

S. No	Description	Part Number	Qty.
1	Drive coupling element	B011201170002	1

7) Safety Valve

S. No	Description	Part Number	Qty.
1	Safety valve	B008401880003	1

8) Anti Vibration Mount

S. No	Description	Part Number	Qty.
1	Anti vibration mount	B001401300022	4
2	Anti vibration mount	B001401300003	1

9) Thermal Valve Kit

S. No	Description	Part Number	Qty.
1	Thermal valve kit 65 deg C (C & CD)	012485140	
1.1	Spring thermal	015401073	1
1.2	Thermal element 65 Deg	B008706030003	1
1.3	O-Ring ID27.6 X 2.4	015400890	1
1.4	Circlip internal B37	000917237	1
2	Thermal valve kit 75 deg C (CV & CDV)	012485141	
2.1	Spring thermal	015401073	1
2.2	Thermal element 75 Deg	B008706030008	1
2.3	O-Ring ID27.6 X 2.4	015400890	1
2.4	Circlip internal B37	000917237	1

B) OTHER MAINTENANCE KITS

S. No	Description	Part Number	Qty.
1	O-Ring Kit	012479649	
1.1	1/8 BSP Bonded seal washer	000959381	3
1.2	1/2 BSP Bonded seal washer	000959387	3
1.3	M22 Bonded seal washer	000959436	1
1.4	3/4BSP Bonded seal washer VITO	000959438	1
1.5	O-Ring ID27.6 X 2.4	015400890	1
1.6	O-Ring ID19.2 X 2.5	015402046	2
1.7	O-Ring ID32.9 X 3.5	015402685	5
1.8	O-Ring ID25.0 X 3.5	015403001	6
1.9	O-Ring ID37.5 X 3.0	035400026	3
1.10	O-Ring ID103.0 X 3.6	415400654	1
1.11	O-Ring ID122.0 X 3.6	415400655	1
1.12	O-Ring ID62.0 X 2.0	990402960	1
1.13	O-Ring ID32.8 X 2.3	990403438	1
1.14	O-Ring_M42 ISO	990404850	1
2	SS Tube and fittings kit	012400663	1
2.1	Tube pulse line EG-22	015320491	1
2.2	PMS coupling 1/4 BSP X 6MM	B009606780009	2

S. No	Description	Part Number	Qty.
2.3	1/8" BSP- DIA 6MM - Elbow fitting	B010505390017	1
2.4	ST Fitting 1/8 TO 6MM OD	015403616	1
2.5	Tube scavenging EG-22	015320490	1

C) Hose kits

S. No	Description	Part Number	Qty.
1	MPV to cooler Hose kit	012479599	
1.1	Hose MPV TO AC EG-22	015318018	1
1.2	O-Ring ID32.9 X 3.5	015402685	2
2	Hose oil injection kit-22KW	012479619	
2.1	Hose Oil injection EG-22	015318015	1
2.2	O-Ring ID25.0 X 3.5	015403001	2
3	Hose tank to cooler kit	012479629	
3.1	Hose TVB TO OC EG-22	015318017	1
3.2	O-Ring ID25.0 X 3.5	015403001	2
4	Hose cooler to tank kit	012479639	
4.1	Hose OC TO TVB EG-22	015318016	1
4.2	O-Ring ID25.0 X 3.5	015403001	2

D) 8000 hours kit - Part Number 012400673

S. No	Description	Part Number	Qty.
1	One time consumable kit	012485145	1
2	8000 hrs valve kit	012400646	1
3	Drive coupling element	B011201170002	1
4	NRV	B004100170001	1
5	Safety valve	B008401880003	1
6	Strainer	B008806100003	1
7	Tube and fittings kit	012485142	1

Lubricant - ELGi Air Lube UT Synthetic

S. No	Description	Part Number
1	ELGi Air Lube UT Synthetic 5 litres (1.3 gallons)	000998092
2	ELGi Air Lube UT Synthetic 20 litres (5.3 gallons)	000998090
3	ELGi Air Lube UT Synthetic 208 litres (55 gallons)	000998093

Lubricant - ELGi Air Lube XD

S. No	Description	Part Number
1	ELGi Air Lube XD 5 litres (1.3 gallons)	000998066
2	ELGi Air Lube XD 20 litres (5.3 gallons)	000998053
3	ELGi Air Lube XD 210 litres (55 gallons)	000998055

Lubricant - ELGi Air Lube FG

S. No	Description	Part Number
1	ELGi Air Lube FG 5 litres (1.3 gallons)	000998077
2	ELGi Air Lube FG 20 litres (5.3 gallons)	000998078
3	ELGi Air Lube FG 210 litres (55 gallons)	000998079

Other Spares

*Parts and quantity required for Cooler to Shroud sealing

S. No	Description	Part Number	Qty
1	OIL COOLER (EG11 & 15)	015315703	1
2	AFTER COOLER (EG11 & 15)	015315704	1
3	OIL COOLER (EG18 & 22)	015315701	1
4	AFTER COOLER (EG18 & 22)	015315702	1
5	PRE FILTER -SS WIRE MESH	015320855	3
6	CLIP ON GASKET	015312471	0.5m
7	SEALING STRIP	41041X223	1.6m

VFD RETROFITMENT KITS ***

1) VFD retro kit C TO CV 11 KW-012486849

S. No	Description	Part Number	Qty.
1	VFD,575V,60HZ,FC-302P11KT6E20,FRAME-B3	B012000510121	1
2	VFD Mounting plate	015311410	1
3	Hex bolt M8 X 16	000906113	4
4	Hex bolt M6 X 16	000906084	2
5	Plain washer M8	000996008	4
6	Spring washer M8 RECT ZYP	000996108	4
7	Spring washer REC SEC M6	000996106	2
8	Control panel EG11-22V 575V 60HZA	018364106	1
9	FIELD STICKER- EG 15HP 575V 60HZ-CV	445400958	1
10	FUSE STICKER EG15-30HP 575V 60HZ-C/CV	445400929	1
11	EMI FILTER 575V,60H-FN 258HV-30-33	B012700510003	1

2) VFD retro kit C TO CV 15 KW-012486859

S. No	Description	Part Number	Qty.
1	VFD,575V,60HZ,FC-302P15KT6E20,FRAME-B3	B012000510122	1
2	VFD Mounting plate	015311410	1
3	Hex bolt M8 X 16	000906113	4
4	Hex bolt M6 X 16	000906084	2
5	Plain washer M8	000996008	4
6	Spring washer M8 RECT ZYP	000996108	4
7	Spring washer REC SEC M6	000996106	2
8	Control panel EG11-22V 575V 60HZA	018364106	1
9	FIELD STICKER- EG 20HP 575V 60HZ-CV	445400959	1
10	FUSE STICKER EG15-30HP 575V 60HZ-C/CV	445400929	1
11	EMI FILTER 575V,60H-FN 258HV-30-33	B012700510003	1

3) VFD retro kit C TO CV 18 KW-012486869

S. No	Description	Part Number	Qty.
1	VFD,575V,60HZ,FC-302P18KT6E20,FRAME-B4	B012000510123	1
2	VFD Mounting plate	015311410	1
3	Hex bolt M8 X 16	000906113	1
4	Hex bolt M6 X 16	000906084	1
5	Plain washer M8	000996008	1
6	Spring washer M8 RECT ZYP	000996108	1

S. No	Description	Part Number	Qty.
7	Spring washer REC SEC M6	000996106	1
8	Control panel EG11-22V 575V 60HZA	018364106	1
9	FIELD STICKER- EG 25HP 575V 60HZ-CV	445400960	1
10	FUSE STICKER EG15-30HP 575V 60HZ-C/CV	445400929	1
11	EMI FILTER 575V,60H-FN 258HV-30-33	B012700510003	1

4) VFD retro kit C TO CV 22 KW-012486879

S. No	Description	Part Number	Qty.
1	VFD,575V,60HZ,FC-302P22KT6E20,FRAME-B4	B012000510124	1
2	VFD Mounting plate	015311410	1
3	Hex bolt M8 X 16	000906113	4
4	Hex bolt M6 X 16	000906084	2
5	Plain washer M8	000996008	4
6	Spring washer M8 RECT ZYP	000996108	4
7	Spring washer REC SEC M6	000996106	2
8	Control panel EG11-22V 575V 60HZA	018364106	1
9	FIELD STICKER- EG 30HP 575V 60HZ-CV	445400926	1
10	FUSE STICKER EG15-30HP 575V 60HZ-C/CV	445400929	1
11	EMI FILTER 575V,60H-FN 258HV-42-33	B012700510004	1

*** VFD Retro fitment kit is applicable for US/CANADA variant only

INSURANCE KIT DETAILS - 50Hz

Insurance kit details			Models						
			11C all	11CD,V all	15C - 7.5,8.5	15C - 10,13	15CD,V - 7.5,8.5	15CD,V -10,13	18C - 7.5,8.5, 10
			Kit No						
S. No	Description	Part Number	012479689	012400664	012400647	012479719	012400665	012400664	012400649
1	INTAKE VALVE KIT (FOR EIV 159 A970012)	972300090	-	-	✓	-	✓	-	✓
2	INTAKE VALVE KIT (FOR EIV 102 A970008)	972300040	✓	✓	-	✓	-	✓	-
3	BLOW DOWN VALVE KIT (102)	972300080	✓	✓	-	✓	-	✓	-
	BLOW DOWN VALVE KIT (159)	972300030	-	-	✓	-	✓	-	✓
4	DRIVE COUPLING ELEMENT 18kW TO 22kW	B011201170002	-	-	-	-	-	-	✓
5	DRIVE COUPLING ELEMENT 11kW TO 15kW	B011201170003	✓	✓	✓	✓	✓	✓	-
6	O-RING AND GASKET KIT	012479649	-	-	✓	-	✓	-	✓
7	O-RING AND GASKET KIT	012479659	✓	✓	-	✓	-	✓	-
8	PULSE LINE, RETURN LINE, OIL LEVEL TUBES,CORRESPONDING FER-RULE AND SLEEVE KIT	012479669	✓	✓	-	✓	-	✓	-
9	PULSE LINE, RETURN LINE, OIL LEVEL TUBES,CORRESPONDING FER-RULE AND SLEEVE KIT	012479679	-	-	✓	-	✓	-	✓
10	SOLENOID VALVE NC,24V, 50/60Hz	B007300990017	✓	✓	✓	✓	✓	✓	✓
11	MINIMUM PRESSURE VALVE KIT	A990293	✓	✓	✓	✓	✓	✓	✓
12	HOSE OIL INJECTION KIT	012479609	✓	✓	-	✓	-	✓	-
13	HOSE OIL INJECTION KIT	012479619	-	-	✓	-	✓	-	✓
14	HOSE MPV TO COOLER KIT	012479599	✓	✓	✓	✓	✓	✓	✓
15	HOSE TANK TO COOLER KIT	012479629	✓	✓	✓	✓	✓	✓	✓
16	HOSE COOLER TO TANK KIT	012479639	✓	✓	✓	✓	✓	✓	✓
17	HOSE MOS OUT TO DRYER KIT	012400671	-	✓	-	-	✓	✓	-
18	HOSE DRYER TO BALL VALVE KIT	012475749	-	✓	-	-	✓	✓	-
19	SUCTION DUCT	015404122	✓	✓	✓	✓	✓	✓	✓

C : Standard version

CV : Standard + Variable frequency drive

D : Dryer version

Insurance kit details			Models						
			18C -13	18CD,V - 7.5,8.5, 10	18CD,V -13	22C - 7.5,8.5, 10	22C-13	22CD,V - 7.5,8.5, 10	22CD,V -13
			Kit No						
S. No	Description	Part Number	01247974 9	01240066 7	01240066 8	01240065 1	01247555 9	01240066 9	01240067 0
1	INTAKE VALVE KIT (FOR EIV 159 A970012)	972300090	-	✓	-	✓	-	✓	-
2	INTAKE VALVE KIT (FOR EIV 102 A970008)	972300040	✓	-	✓	-	✓	-	✓
3	BLOW DOWN VALVE KIT (102)	972300080	✓	-	✓	-	✓	-	✓
	BLOW DOWN VALVE KIT (159)	972300030	-	✓	-	✓	-	✓	-
4	DRIVE COUPLING ELEMENT 18kW TO 22kW	B011201170002	✓	✓	✓	✓	✓	✓	✓
5	DRIVE COUPLING ELEMENT 11kW TO 15kW	B011201170003	-	-	-	-	-	-	-
6	O-RING AND GASKET KIT	012479649	-	✓	-	✓	-	✓	-
7	O-RING AND GASKET KIT	012479659	✓	-	✓	-	✓	-	✓
8	PULSE LINE, RETURN LINE, OIL LEVEL TUBES,CORRESPONDING FER-RULE AND SLEEVE KIT	012479669	✓	-	✓	-	✓	-	✓
9	PULSE LINE, RETURN LINE, OIL LEVEL TUBES,CORRESPONDING FER-RULE AND SLEEVE KIT	012479679	-	✓	-	✓	-	✓	-
10	SOLENOID VALVE NC,24V, 50/60Hz	B007300990017	✓	✓	✓	✓	✓	✓	✓
11	MINIMUM PRESSURE VALVE KIT	A990293	✓	✓	✓	✓	✓	✓	✓
12	HOSE OIL INJECTION KIT	012479609	✓	-	✓	-	✓	-	✓
13	HOSE OIL INJECTION KIT	012479619	-	✓	-	✓	-	✓	-
14	HOSE MPV TO COOLER KIT	012479599	✓	✓	✓	✓	✓	✓	✓
15	HOSE TANK TO COOLER KIT	012479629	✓	✓	✓	✓	✓	✓	✓
16	HOSE COOLER TO TANK KIT	012479639	✓	✓	✓	✓	✓	✓	✓
17	HOSE MOS TO DRYER KIT	012400671	-	✓	✓	-	-	✓	✓
18	HOSE DRYER TO BALL VALVE KIT	012475749	-	✓	✓	-	-	✓	✓
19	SUCTION DUCT	015404122	✓	✓	✓	✓	✓	✓	✓

C : Standard version

CV : Standard + Variable frequency drive

D : Dryer version

NOTE

- ** Parts not included in insurance kit
- Calibration must be carried out if any sensors are replaced. For doing so please contact ELGi dealer/ service engineer.

INSURANCE KIT DETAILS - 60Hz

Insurance kit details			Models					
			11C all	11CD,V all	15C all	15CD,V all	18C – 100,125	18C – 150,175
			Kit No					
S. No	Description	Part Number	01247968 9	01240066 4	01247971 9	01240066 4	012400649	01247974 9
1	INTAKE VALVE KIT (FOR EIV 159 A970012)	972300090	-	-	-	-	✓	-
2	INTAKE VALVE KIT (FOR EIV 102 A970008)	972300040	✓	✓	✓	✓	-	✓
3	BLOW DOWN VALVE KIT (102)	972300080	✓	✓	✓	✓	-	✓
	BLOW DOWN VALVE KIT (159)	972300030	-	-	-	-	✓	-
4	DRIVE COUPLING ELEMENT 18kW TO 22kW	B011201170002	-	-	-	-	✓	✓
5	DRIVE COUPLING ELEMENT 11kW TO 15kW	B011201170003	✓	✓	✓	✓	-	-
6	O-RING AND GASKET KIT	012479649	-	-	-	-	✓	-
7	O-RING AND GASKET KIT	012479659	✓	✓	✓	✓	-	✓
8	PULSE LINE, RETURN LINE, OIL LEVEL TUBES,CORRESPONDING FERRULE AND SLEEVE KIT	012479669	✓	✓	✓	✓	-	✓
9	PULSE LINE, RETURN LINE, OIL LEVEL TUBES,CORRESPONDING FERRULE AND SLEEVE KIT	012479679	-	-	-	-	✓	-
10	SOLENOID VALVE NC,24V, 50/60Hz	B007300990017	✓	✓	✓	✓	✓	✓
11	MINIMUM PRESSURE VALVE KIT	A990293	✓	✓	✓	✓	✓	✓
12	HOSE OIL INJECTION KIT	012479609	✓	✓	✓	✓	-	✓
13	HOSE OIL INJECTION KIT	012479619	-	-	-	-	✓	-
14	HOSE MPV TO COOLER KIT	012479599	✓	✓	✓	✓	✓	✓
15	HOSE TANK TO COOLER KIT	012479629	✓	✓	✓	✓	✓	✓
16	HOSE COOLER TO TANK KIT	012479639	✓	✓	✓	✓	✓	✓
17	HOSE MOS OUT TO DRYER KIT	012400671	-	✓	-	✓	-	-
18	HOSE DRYER TO BALL VALVE KIT	012475749	-	✓	-	✓	-	-
19	SUCTION DUCT	015404122	✓	✓	✓	✓	✓	✓

C : Standard version

CV : Standard + Variable frequency drive

D : Dryer version

Insurance kit details			Models					
			18CD,V - 100,125	18CD,V - 150,175	22C - 100,125 ,150	22C-175	22CD,V - 100,125 ,150	22CD,V -175
			Kit No					
S. No	Description	Part Number	01240066 7	01240066 8	01240065 1	01247555 9	01240066 9	01240067 0
1	INTAKE VALVE KIT (FOR EIV 159 A970012)	972300090	✓	-	✓	-	✓	-
2	INTAKE VALVE KIT (FOR EIV 102 A970008)	972300040	-	✓	-	✓	-	✓
3	BLOW DOWN VALVE KIT (102)	972300080	-	✓	-	✓	-	✓
	BLOW DOWN VALVE KIT (159)	972300030	✓	-	✓	-	✓	-
4	DRIVE COUPLING ELEMENT 18kW TO 22kW	B011201170002	✓	✓	✓	✓	✓	✓
5	DRIVE COUPLING ELEMENT 11kW TO 15kW	B011201170003	-	-	-	-	-	-
6	O-RING AND GASKET KIT	012479649	✓	-	✓	-	✓	-
7	O-RING AND GASKET KIT	012479659	-	✓	-	✓	-	✓
8	PULSE LINE, RETURN LINE, OIL LEVEL TUBES,CORRESPONDING FERRULE AND SLEEVE KIT	012479669	-	✓	-	✓	-	✓
9	PULSE LINE, RETURN LINE, OIL LEVEL TUBES,CORRESPONDING FERRULE AND SLEEVE KIT	012479679	✓	-	✓	-	✓	-
10	SOLENOID VALVE NC,24V, 50/60Hz	B007300990017	✓	✓	✓	✓	✓	✓
11	MINIMUM PRESSURE VALVE KIT	A990293	✓	✓	✓	✓	✓	✓
12	HOSE OIL INJECTION KIT	012479609	-	✓	-	✓	-	✓
13	HOSE OIL INJECTION KIT	012479619	✓	-	✓	-	✓	-
14	HOSE MPV TO COOLER KIT	012479599	✓	✓	✓	✓	✓	✓
15	HOSE TANK TO COOLER KIT	012479629	✓	✓	✓	✓	✓	✓
16	HOSE COOLER TO TANK KIT	012479639	✓	✓	✓	✓	✓	✓
17	HOSE MOS TO DRYER KIT	012400671	✓	✓	-	-	✓	✓
18	HOSE DRYER TO BALL VALVE KIT	012475749	✓	✓	-	-	✓	✓
19	SUCTION DUCT	015404122	✓	✓	✓	✓	✓	✓

C : Standard version

CV : Standard + Variable frequency drive

D : Dryer version

NOTE

- * * Parts not included in insurance kit
- Calibration must be carried out if any sensors are replaced. For doing so please contact ELGi dealer/ service engineer.

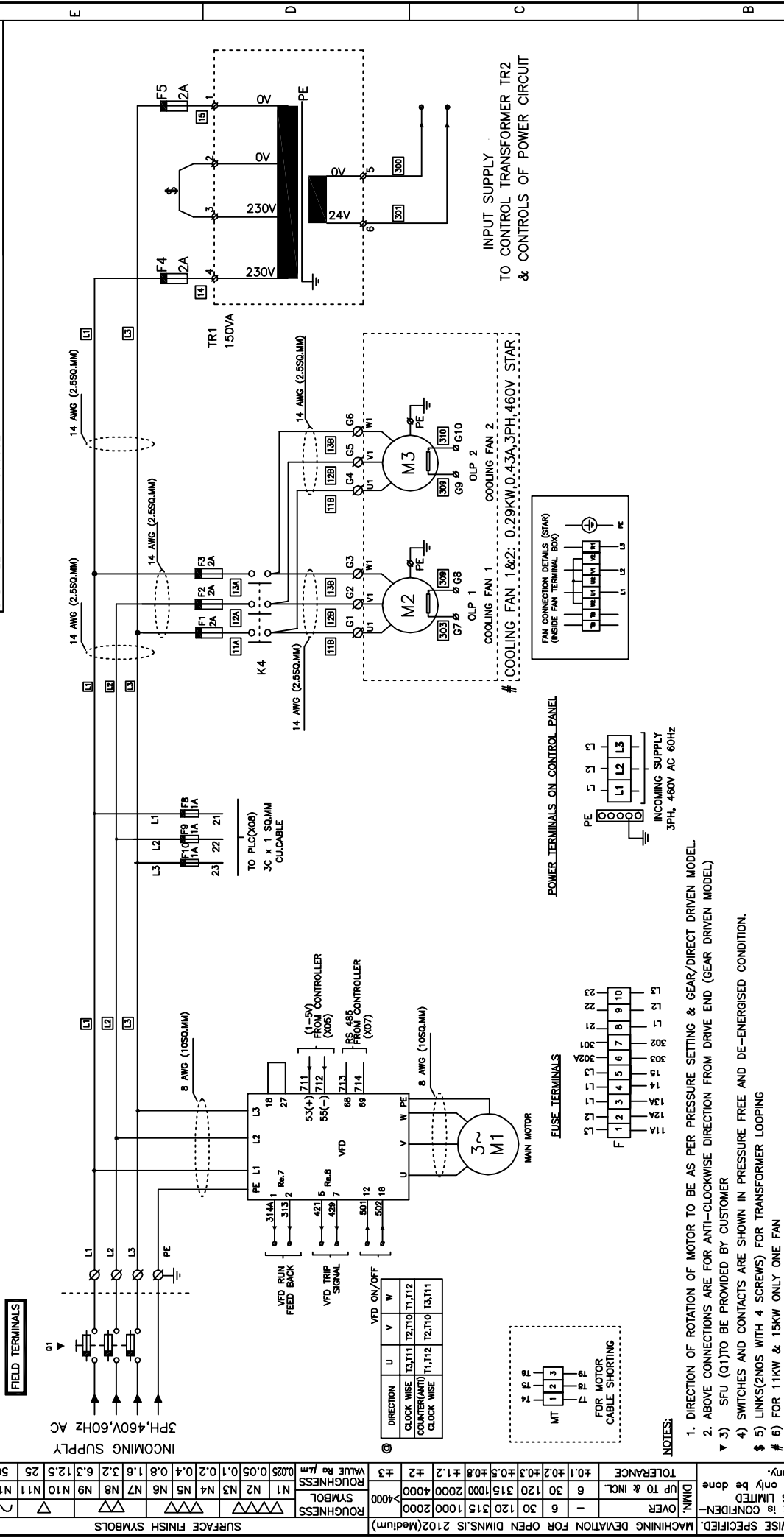

ITEM NO.	DESCRIPTION	QTY	DRAWING No.	REV.	REMARKS
1	CONTROL PANEL EG11-EG22 CV, 460V, 60HZ, III				
2	MAT'L				

DESIGNED	NAME	DATE
CS	MANOJ	30.11.16

CAD	CHECKED	APPD.
MANOJ		

DRG. No.	DRG. SHEET	OF	REVISION
01	83	6352	7

REV. NO.	ECO.No.	DATE	DESCRIPTION	CHD.BY.
6				

ELGI ELGI EQUIPMENTS LTD.,
COIMBATORE - INDIA.

STARTER CUM CONTROL PANEL

SCALE
NTS

DO NOT SCALE THIS DRG. IF IN DOUBT, ASK ENGG. DEPT.

POWER TERMINALS ON CONTROL PANEL

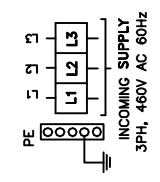

FUSE TERMINALS

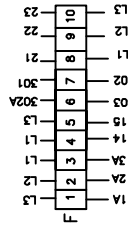

FOR MOTOR CABLE SHORTING

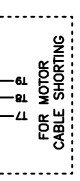

NOTES:

- DIRECTION OF ROTATION OF MOTOR TO BE AS PER PRESSURE SETTING & GEAR/DIRECT DRIVEN MODEL.
- ABOVE CONNECTIONS ARE FOR ANTI-CLOCKWISE DIRECTION FROM DRIVE END (GEAR DRIVEN MODEL)
- SFU (Q1) TO BE PROVIDED BY CUSTOMER
- SWITCHES AND CONTACTS ARE SHOWN IN PRESSURE FREE AND DE-ENERGISED CONDITION.
- LINKS (ZNOS WITH 4 SCREWS) FOR TRANSFORMER LOOPING
- FOR 11KW & 15KW ONLY ONE FAN
- MOTOR CONNECTION DETAILS FOR PRESSURE VARIANTS (GEAR & DIRECT DRIVEN MODEL)
- OVER LOAD PROTECTION FOR FAN
- 3X150MM CABLE (BLACK x BLACK x BLACK) TO BE BROUGHT SEPARATELY FROM FUSE TERMINAL TO NEURON III X08 CONNECTOR
- X08 PIN CONNECTOR CONNECTION TO BE ENSURED ACCORDING TO MOTOR CONNECTION.

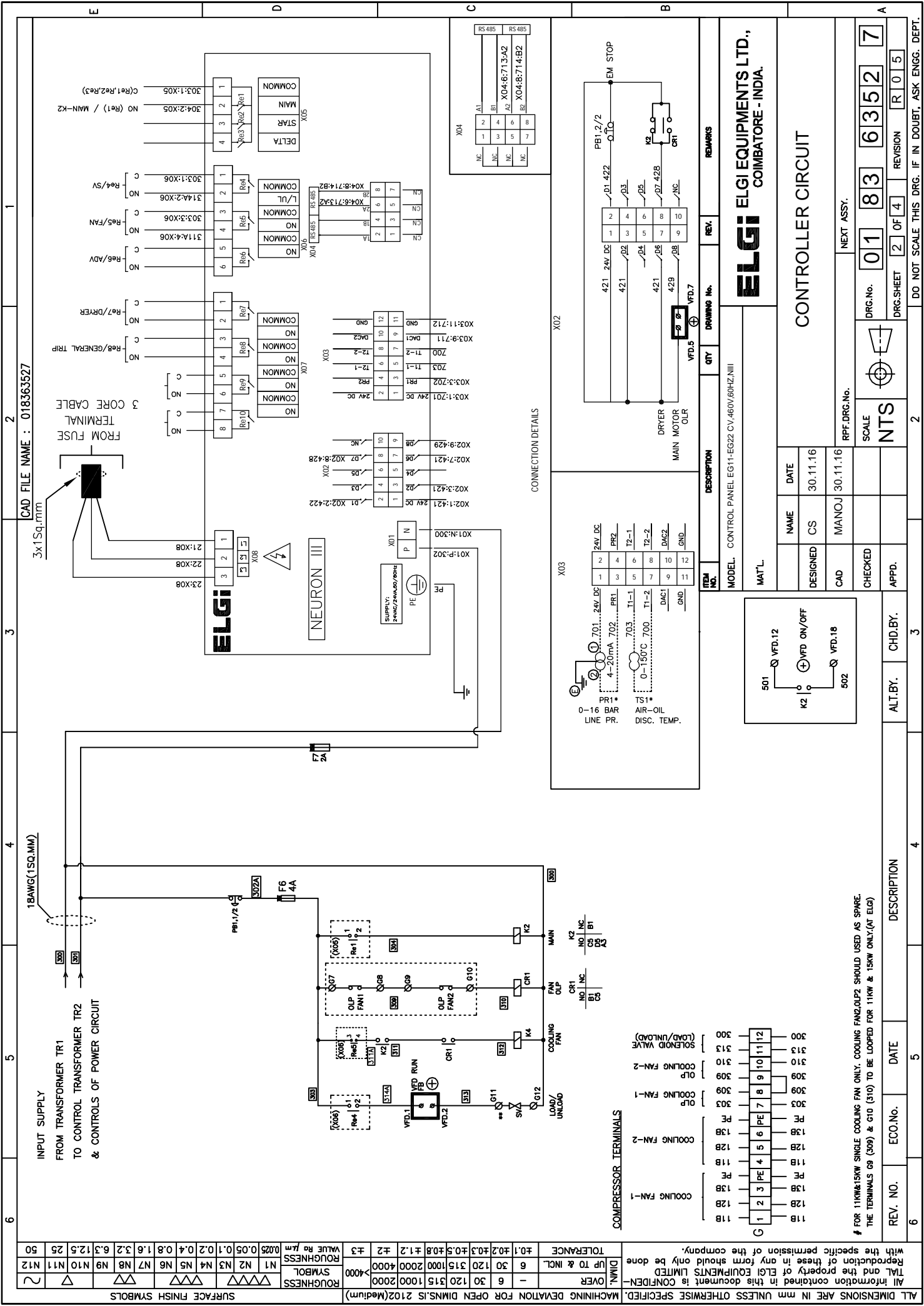

ROUGHNESS	SYMBOL	VALUE	ROUGHNESS	SYMBOL	VALUE
N1	▽	0.025	N1	▽	12.5
N2	▽	0.05	N2	▽	25
N3	▽	0.1	N3	▽	50
N4	▽	0.2	N4	▽	100
N5	▽	0.4	N5	▽	200
N6	▽	0.8	N6	▽	400
N7	▽	1.6	N7	▽	1000
N8	▽	3.2	N8	▽	2000
N9	▽	6.3	N9	▽	4000
N10	▽	12.5	N10	▽	8000
N11	▽	25	N11	▽	16000
N12	▽	50	N12	▽	32000

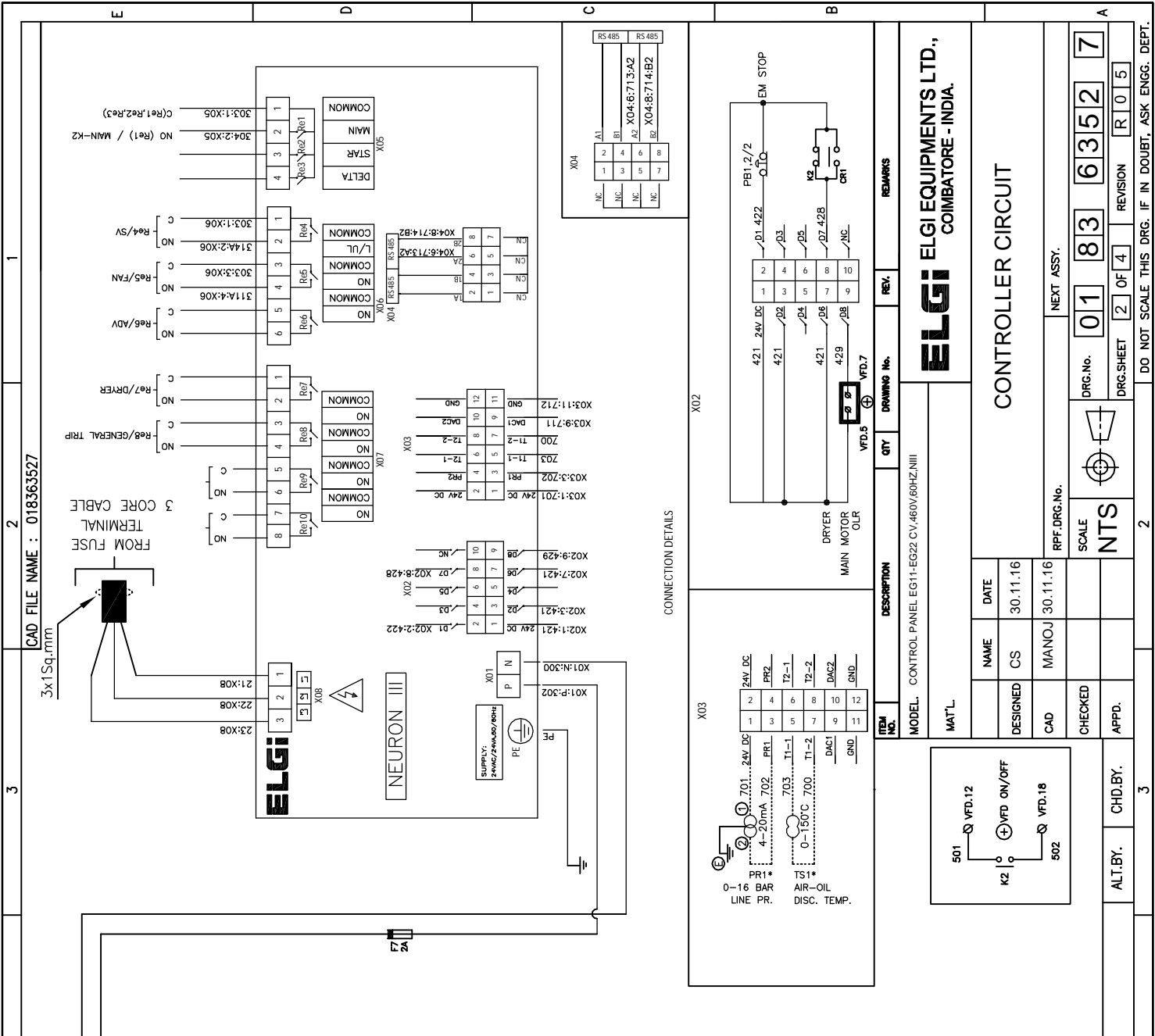
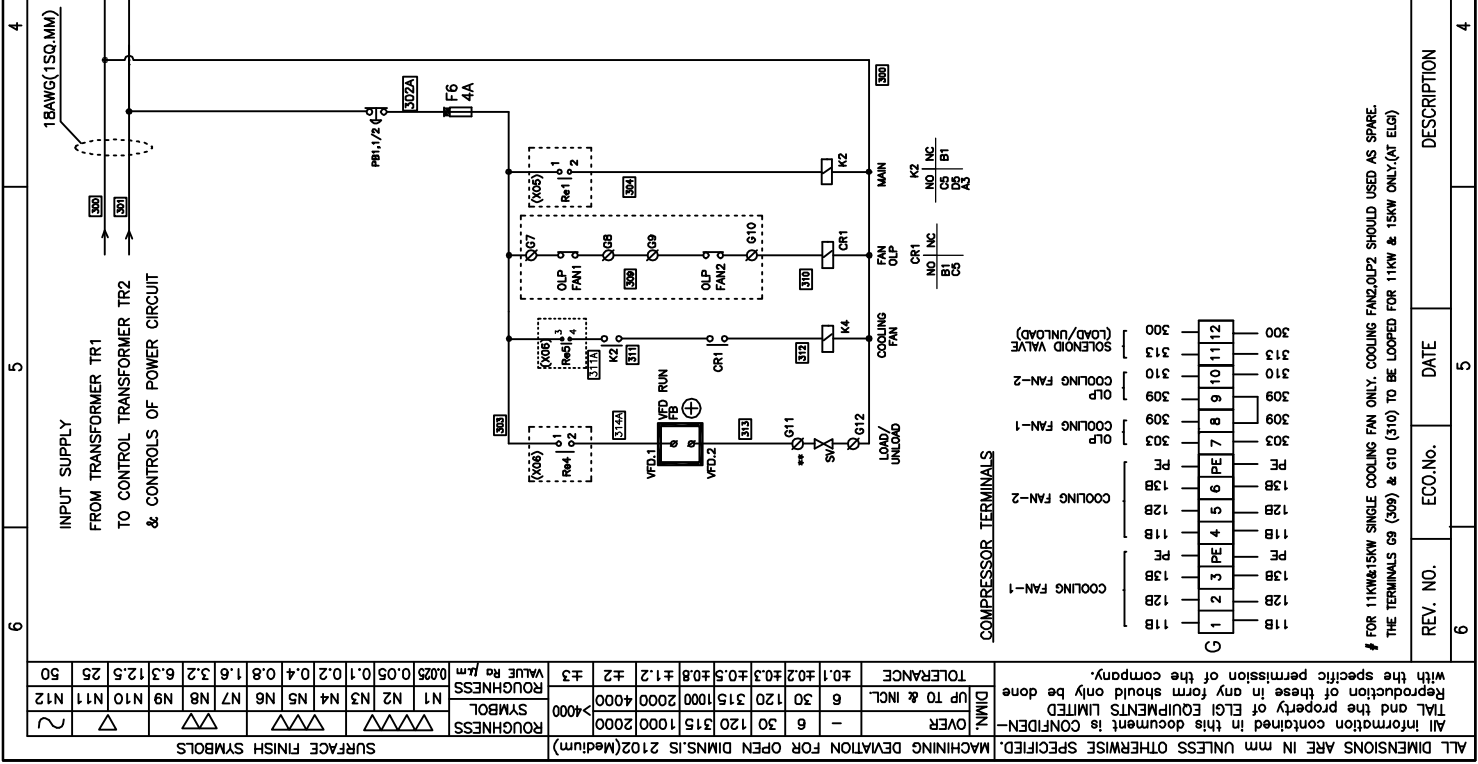

ITEM NO.	DESCRIPTION	QTY	DRAWING No.	REV.	REMARKS
1	CONTROL PANEL EG11-EG22 CV, 460V, 60HZ, NIII				
2	MAT'L				

NAME	DATE	SCALE	DRG. No.	REV. No.	REVISION
DESIGNED CS	30.11.16	NTS	01	83	6352
CAD MANOJ	30.11.16				
CHECKED					
APPD.					

ELGI EQUIPMENTS LTD., COIMBATORE - INDIA.

CONTROLLER CIRCUIT

SCALE NTS

DRG. No. 01 83 6352 7

REV. No. 2 OF 4

REVISION R 0 5

DO NOT SCALE THIS DRG. IF IN DOUBT, ASK ENGG. DEPT.

REV. NO.	ECO. No.	DATE	DESCRIPTION
1			
2			
3			
4			
5			
6			

ALL DIMENSIONS ARE IN mm UNLESS OTHERWISE SPECIFIED.

MACHINING DEVIATION FOR OPEN DIMS. S. 2102 (Medium)

ROUGHNESS

OVER

UP TO & INCL.

TOLERANCE

±0.1

±0.2

±0.3

±0.5

±0.8

±1.2

±2

±3

±4000

>4000

REPRODUCTION OF THESE IN ANY FORM SHOULD ONLY BE DONE WITH THE SPECIFIC PERMISSION OF THE COMPANY.

ALL INFORMATION CONTAINED IN THIS DOCUMENT IS CONFIDENTIAL AND THE PROPERTY OF ELGI EQUIPMENTS LIMITED

FOR 11KW&15KW SINGLE COOLING FAN ONLY. COOLING FAN2, O/P2 SHOULD USED AS SPARE THE TERMINALS C9 (509) & C10 (510) TO BE LOOPED FOR 11KW & 15KW ONLY.(AT ELGI)

NEXT ASSY.

RPF. DRG. No.

SL.NO	CODE	DESCRIPTION	MAKE	RATING	ELGI PART NO	QTY
1	VFD	DRIVE (ELGI SCOPE)	DANFOSS	11KW-22KW	-	1
2	K2	CONTROL CONTACTOR	SIEMENS	3RH21 31-1AB00,10A+3RT29 16-1CB00	018362749+018400196	1
3	K4	POWER CONTACTOR FOR COOLING FAN	SIEMENS	9A3RT20 23-1AC20+3RT29 26-1CB00	008900170+018400197	1
4	TR1	MULTI TAP TRANSFORMER	PLITRON	150VA, 0-0-230V-230V/0-24V	00893703A	1
5	CR1	CONTROL RELAY	PHOENIX	2961192	008946236	1
6	PB1	EMERGENCY STOP PUSH BUTTON(FULL DIAL)	TEKNIC	2AML4 + 2 S2 CONTACT	008940030	1
7	L1,L2,L3	TERMINAL BLOCK - PHASE	PHOENIX	RSC6-FE WITH END CLAMP	00894642F	3
8	PE	EARTH STRIP FOR COMPONENT EARTH WITH 5mm SCREW WITH FLAT & SPRING WASHER	-	COPPER WITH TIN COATING	-	1
9	G	CONTROL TERMINALS	WAGO	281-101	018362734	AS PER DWG
10	PE	CONTROL TERMINALS (YELLOW GREEN)	WAGO	281-107	018362733	2
11	F	FUSE TERMINALS	WAGO	281-611	018362735	AS PER DWG
12	F7	GLASS FUSE 20 x 5	PROTECTOR	SLOW BLOW 2A	00894642A	-
13	F6	GLASS FUSE 20 x 5	PROTECTOR	SLOW BLOW 4A	00894644A	-
14	F1-F5	CERAMIC FUSE 20 x 5	LITTEL/BEL	TIME LAG 2A	018900029	-
15	F8-F10	CERAMIC FUSE 20 x 5	LITTEL/BEL	TIME LAG 1A	018900028	-
16	NIII	NEURON CONTROLLER	ELGI	-	X0180912	1
17	MT	MOTOR CONNECTION TERMINALS	CONNECTWELL	CTS16U	008946320	3
18	CONNECTERS	PLC CONNECTER SET	WAGO	231-102/026-000 713-1105 713-1106 713-1104 231-204/026-000 231-206/026-000 231-108/026-000 231-203/026-000	00897903W	1 SET
19	-	END STOPPER	WAGO	249-117	018362736	6
20	PS1	PRESSURE TRANSMITTER	DANFOSS	0-16 BAR	00897902N	1
21	TS1	TEMPERATURE TRANSMITTER	DANFOSS	0-150°C	018400076	1

TRANSFORMER TAPPINGS & OLR SETTING NEED TO BE CHANGED ACCORDING TO VOLTAGE CONDITION AT SITE

MODEL	VFD PART No.
EG11	B012000510023
EG15	B012000510024
EG18	B012000510025
EG22	B012000510019

ELGI ELGI EQUIPMENTS LTD.,
COIMBATORE - INDIA.

BILL OF MATERIALS

ITEM No.	DESCRIPTION	QTY	DRAWING No.	REV.	REMARKS
MODEL	CONTROL PANEL EG11-EG22 CV,460V,60HZ,NIII				
MAT'L					
DESIGNED	NAME	DATE	DRG.No.	REV.	
CS	MANOJ	30.11.16	01	83	6352
CAD	MANOJ	30.11.16	3	OF 4	REVISION
CHECKED					
APPD.					

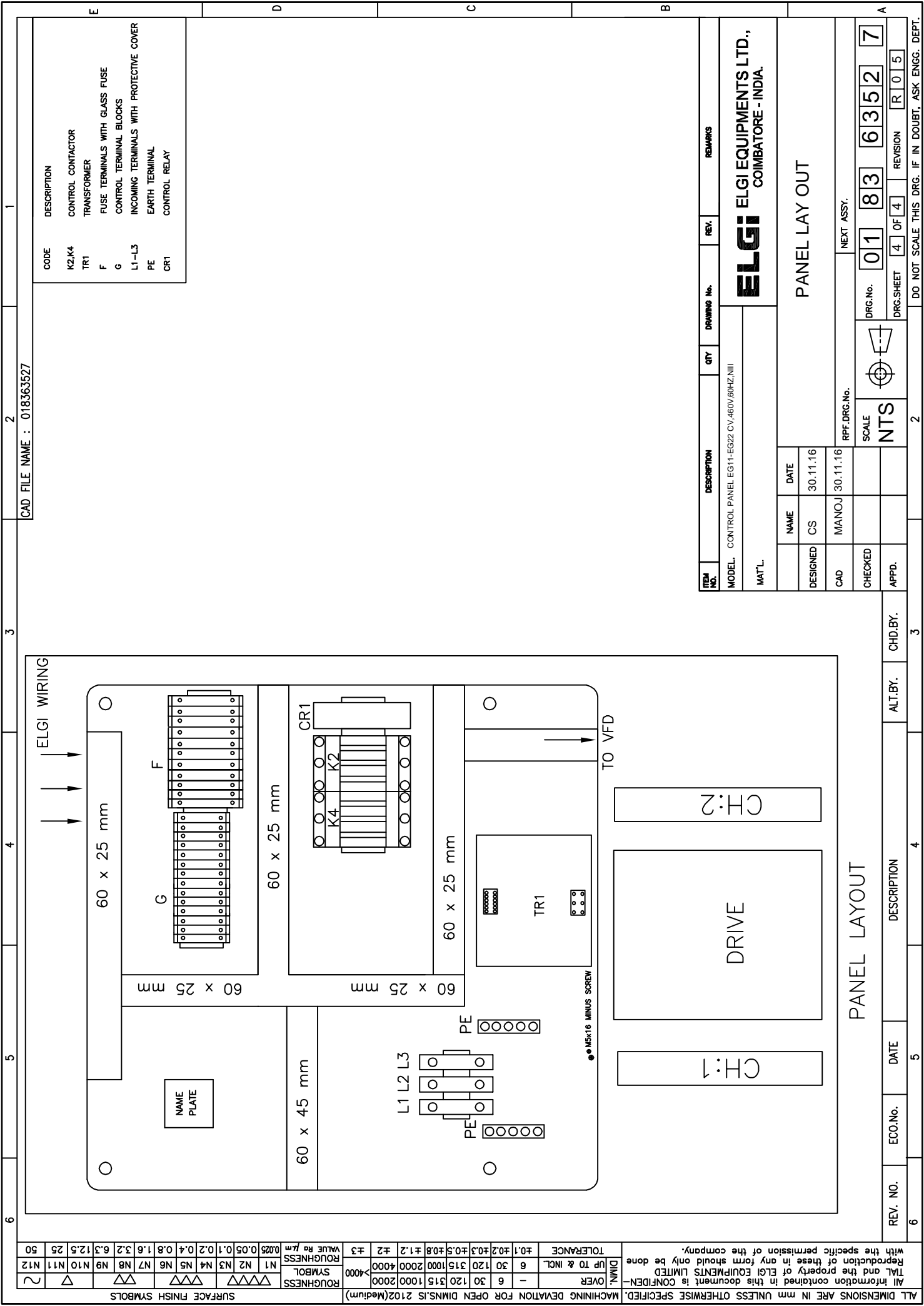

CAD FILE NAME : 018363527

CODE	DESCRIPTION
K2,K4	CONTROL CONTACTOR
TR1	TRANSFORMER
F	FUSE TERMINALS WITH GLASS FUSE
G	CONTROL TERMINAL BLOCKS
L1-L3	INCOMING TERMINALS WITH PROTECTIVE COVER
PE	EARTH TERMINAL
CR1	CONTROL RELAY

ITEM NO.	DESCRIPTION	QTY	DRAWING No.	REV.	REMARKS
	MODEL. CONTROL PANEL EG11-EG22 CV,460V,60HZ,NIII				
	MAT'L				

ELGI	ELGI EQUIPMENTS LTD., COIMBATORE - INDIA.
------	--

PANEL LAY OUT	
DESIGNED	CS
DATE	30.11.16
CAD	MANOJ
DATE	30.11.16
CHECKED	
APPD.	

DRG.No.	01	83	6352	7
DRG.SHEET	4	OF	4	REVISION
				R 0 5

SCALE	NTS
RPF.DRG.No.	
NEXT ASSY.	

PANEL LAYOUT

REV. NO.	ECO.No.	DATE	DESCRIPTION	ALT.BY.	CHD.BY.
6		5			3

DO NOT SCALE THIS DRG. IF IN DOUBT, ASK ENGG. DEPT.

ROUGHNESS SYMBOL	ROUGHNESS VALUE Ra μm	TOLERANCE	DIMENSIONAL
▽	N1	±0.1	OVER
▽	N2	±0.2	UP TO & INCL.
▽	N3	±0.3	
▽	N4	±0.5	
▽	N5	±0.8	
▽	N6	±1.2	
▽	N7	±2.0	
▽	N8	±3.0	
▽	N9	±5.0	
▽	N10	±8.0	
▽	N11	±12.0	
▽	N12	±20.0	

ROUGHNESS SYMBOL	ROUGHNESS VALUE Ra μm
▽	>4000

ALL DIMENSIONS ARE IN mm UNLESS OTHERWISE SPECIFIED. MACHINING DEVIATION FOR OPEN DIMS. IS 2102(Medium) SURFACE FINISH SYMBOLS

Brief introduction to VFD in the global series compressor

In VFD model compressors, the Variable Frequency Drive (VFD) is integrated with the compressor. Simply put, the main motor is controlled through VFD instead of the star delta starter.

Hardware (wiring) details

The figure illustrates the wiring integrations with the VFD and control panel/controller. The following section describes the purpose of each connection in this architecture.

1. 3 Phase connection to VFD

The input side phase sequence is critical for the fan direction of rotation. During installation, the fan direction needs to be checked and, if required, change the phase sequence. However, the motor phase sequence is controlled by VFD.

2. Motor connection

It is wired for the required phase sequence with respect to your compressor requirements. Do not change the configuration.

3. Start command to VFD

The Start/Stop command that flows to the VFD from the controller rotates/stops the main motor.

4. Run feedback signal

After reaching 40% of speed, VFD sends a run feedback signal to the controller to switch on the solenoid valve to the start loading process.

5. Trip command from VFD

During any abnormalities in the VFD drive, a trip signal flows to the controller to stop the compressor. (To troubleshoot, refer to the VFD manual.)

6. Pressure feedback signal

The delivery pressure feedback signal propagates from the controller (analogue output CH1) to VFD to control motor speed. The feedback is an analogue voltage signal with a range 1-5 V.

7. RS485 communication

An RS485 communication medium occurs between the VFD and controller to read/write parameters such as voltage, current, power, frequency, and the analog scale setting.

All the above connections are factory wired and you only need to connect the incoming supply to the compressor with the right wire size and incoming protection fuse (as per the compressor manual).

NOTE

Ensure the dip switch in VFD (right behind the display) is set in voltage mode.

Software details (programming details)

Based on the compressor rating, VFD parameters are pre-programmed in the Setup 1 location and in the compressor controller. The setting details are available in Annexure 1.

During installation and commissioning, you can tune the PI at your own site to ensure smooth speed control according to your requirements. Except for PI settings in the controller, no other setting is required to change. Similarly

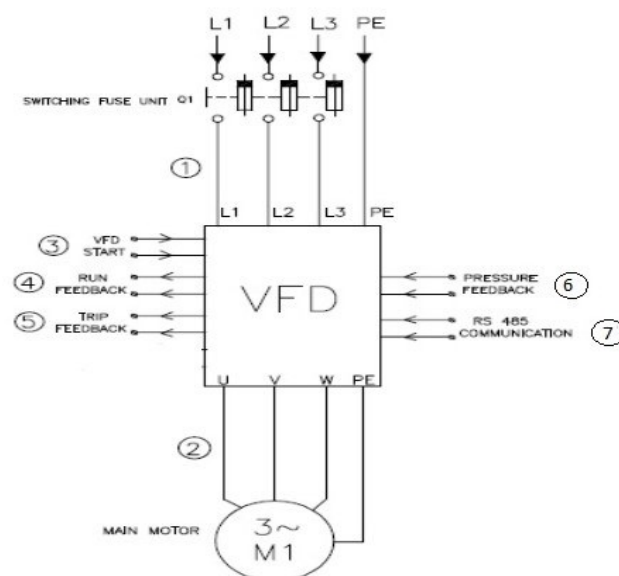

in VFD, all settings are pre-programmed, so you need not change any of the settings. During operation, you can change the load pressure set point according to your requirements. .

The following parameters are important for the correct drive operation

- Right analog output feedback from the controller to VFD. (1V corresponds to AO scaling low reference and 5V corresponds to AO scaling high reference.)
- The AO high and low reference scaling settings are configured in the factory setting menu in the Neuron II controller. You can view these parameters in the NII controller. The corresponding low ref and high ref settings must be verified in drive parameters 614 and 615, respectively.
- Ensure the dip switch in VFD (right behind the display) is set in voltage mode.
- Enter motor nameplate details in VSD settings (such as voltage, current (I max value-SF current), power, frequency, and RPM).
- You need to adjust PI parameters at your site for effective tuning to ensure smooth speed control to meet your exact requirements.
- You can edit the parameters 614 and 615 in the VFD through the controller. Ensure this value matches the

AO scaling in the controller. Good practice is to not attempt to change these settings on your own. Instead contact ELGi .

For more details about VFD parameters and troubleshooting, refer to the VFD manual that shipped along with the compressor.

Operation

The Start command enables the compressor motor to start and rotate in the required direction. It is issued from the controller to VFD.

After receiving the Start command, VFD accelerates the compressor motor to 40% speed (minimum speed setting in the controller). After ensuring the run feedback signal from VFD and reaching 40% speed, the controller actuates the solenoid valve to start the loading process. Only then does VFD increase motor speed from 40% to 100% (max speed setting in the controller).

Until the Target pressure is reached, the VFD delivers 100% speed. Once the Target pressure is reached and the demand becomes low, the speed reduces and stabilizes to maintain the set pressure. The speed limit varies from 40% to 100% speed based on the demand and pressure range.

Even when speed reaches 40% of the rating and the demand is still low, pressure increases and reaches load pressure of +7 psi. At this point, the compressor switches to unload mode and starts running at unload speed.

If pressure reduces and reaches the load point of the controller, then the compressor starts loading and the speed increases from 40% to maintain the set pressure.

- If the machine runs in unload for more than the stand by time set in the controller, the compressor stops and goes to standby mode. It waits till pressure reaches the set load point in the controller and then starts as per the start sequence.

If the drive does not respond to quick pressure changes (drop in set pressure) or responds very fast to pressure changes (continuous increase and decrease in speed to maintain set pressure), then adjust P and I settings in the NII controller**.

** One-time fine tuning is recommended during installation by an expert.

If you do not opt for speed change with respect to pressure, and instead opt to operate in fixed speed, then choose the optimum speed enable option in the operator setting. The compressor then operates at optimum speed during load and at unload speed during unload.

NOTE

Max speed, min speed, optimum speed, and unload speed are all factory settings. Do not attempt to change these settings. You can view set speed details in the operator menu

Trouble shooting

	Fault Description	Details to be checked
1	The motor runs at full speed or low speed (no speed change with respect to pressure)	The PI settings in the controller to be reduced to have the speed respond to pressure variation. The compressor does not develop the required pressure (under-rating of the compressor) and always runs at max speed of the motor. Check the controller A/O scaling value (viewed in the operator menu) with respect to the VFD parameter 614,615. Ensure unload is enabled in the controller. Ensure optimum speed setting is enabled.
2	The motor speed changes frequently and makes noise (acceleration and deceleration)	The PI setting is too short. It continuously gives feedback to change motor speed and produces very high response to pressure variation. In this case, PI values must be increased to have smooth speed changeover.
3	The motor runs at low speed continuously (30Hz)	The compressor runs in unload mode. Air demand is less and the standby time set is more than 3 minutes.
4	The compressor minimum and maximum speed is not as per minimum and maximum speed limits set in the controller	Check AO scaling values in the controller (operator menu view). Ensure VFD parameters 614 and 615 are the same.
5	Motor not starting	Ensure VFD processes the start command and VFD display shows Ramping or Running. Check for any Trip Message in the VFD. Verify that the ON status LED in the VFD glows. If not, press the Auto on button in the VFD and ensure the ON LED glows. Check the pressure is more than load pressure and the compressor is in standby mode.

	Fault Description	Details to be checked
6	Compressor does not switch to load mode	Check the run feedback signal from VFD. Verify that the controller issues the load command. Ensure that the solenoid valve receives supply and energizes.
7	Compressor trips from VFD and the controller displays VFD fault	Verify if the motor consumes more power than the nameplate value. Ensure that the VFD parameter is correct. Check the VFD trip history/details of the trip and make the required corrections as per VFD troubleshooting guidelines.

FAQ

What is target pressure?

It is a set load pressure that VFD needs to maintain by varying compressor motor speed. If demand is low, speed reduces and pressure remains constant. If demand continues to be low, pressure increases and reaches load pressure

- Of 7 psi. When this occurs, the compressor switches to unload mode and starts operating at unload speed.

What is the significance of P&I settings in the controller?

The change in pressure with respect to time is not linear in all the cases, but the rate of change in pressure depends on receiver and pipeline capacity of a particular customer. The higher the storage capacity, the greater is the time available for speed correction and for producing a response to pressure requirement, and the reverse is also true. In such a case, the P & I setting must be adjusted at the site for smooth speed change-over. One-time fine tuning is required at the site and the settings can be adjusted through the controller.

Why must be the direction of rotation verified in VFD output?

VFD output always causes clockwise rotation irrespective of the input connection to the VFD. In case the compressor needs to operate counterclockwise, the motor connection from VFD output must be reversed. (Refer to the circuit right direction of rotation.)

What is the meaning of main motor overload trip in the controller?

The VFD trip is connected to the controller for main motor trip display in the controller. Refer to VFD trip information, verify the type of trip, and make corrections as per the manual.

What is the significance of the AO scale setting in the controller?

AO scaling with respect to 1V corresponds to min speed and 5V corresponds to max speed. Based on this scaling range and analogue input reference, VFD calculates the required speed/frequency at which the compressor motor must operate. AO scaling values in the controller settings and in the drive parameters 614 and 615 need to be the same.

What is the significance of max and min speed settings in the controller?

This imposes limitation on Max/Min speed for selected compressor models. This limitation will change between compressor models. This setting must not exceed the AO scaling range.

What is the significance of the optimum speed setting in the controller?

If the compressor needs to operate in fixed speed, then optimum speed must be enabled in the operator setting, If optimum speed is enabled, the compressor will operate at optimum speed during load and at unload speed during unload. This feature affords flexibility to customers if the compressed air circuit has more than one VFD machine and one machine for speed control. Typically, one machine is enough.

The optimum speed setting lies between the range of min and max speed settings.

What is the significance of the unload speed setting in the controller?

Unload speed is nothing but the speed at which the compressor must operate during unload. This setting must be in the range of min speed and max speed and less than optimum speed.

Annexure 1

ID	Name	Setup 1
1	Language	English
2	Motor Speed Unit	RPM
10	Active Set-up	Set-up 1
20	Display Line 1.1 Small	Motor Voltage
21	Display Line 1.2 Small	Motor current
22	Display Line 1.3 Small	Speed [RPM]
23	Display Line 2 Large	Analog Input 53
24	Display Line 3 Large	Frequency
40	[Hand on] Key on LCP	Disabled
41	[Off] Key on LCP	Disabled
42	[Auto on] Key on LCP	Enabled
43	[Reset] Key on LCP	Enabled
100	Configuration Mode	Speed open loop
101	Motor Control Principle	VVC+
104	Overload Mode	Normal torque
106	Clockwise Direction	Normal
120	Motor Power [kW]	Motor name plate
122	Motor Voltage	Motor name plate
123	Motor Frequency	Motor name plate
124	Motor Current	Motor name plate * SF
125	Motor Nominal Speed	Motor name plate
139	Motor Poles	Motor name plate
190	Motor Thermal Protection	ETR Trip1
191	Motor External Fan	Yes
300	Reference Range	Min - Max
301	Reference/Feedback Unit	RPM
302	Minimum Reference	900
303	Maximum Reference	2400
304	Reference Function	Sum
310-[0]	Preset Reference	0
313	Reference Site	Remote
315	Reference Resource 1	Analog Input 53
316	Reference Resource 2	No Function
317	Reference Resource 3	No Function
340	Ramp 1 Type	Linear
341	Ramp 1 Ramp Up Time	
342	Ramp 1 Ramp Down Time	

ID	Name	Setup 1
410	Motor Speed Direction	Clockwise
411	Motor Speed Low Limit [RPM]	900
413	Motor Speed High Limit [RPM]	2400
419	Max Output Frequency	80
512	Terminal 27 Digital Input	Coast inverse
540	Relay->Option relay 7-> Function relay	Running
540	Relay->Option relay 8-> Function relay	Alarm
610	Terminal 53 Low Voltage	1
611	Terminal 53 High Voltage	5
614	Terminal 53 Low Ref./Feedb. Value	*** (Edit from NII Controller)
615	Terminal 53 High Ref./Feedb. Value	*** (Edit from NII Controller)
830	Protocol	Modbus RTU
832	FC Port Baud rate	9600
833	Parity/Stop bits	No Parity,1 Stop bit
843-[0]	PCD read Configuration	(1603) – Status word
844-[1]	PCD read Configuration	(1605) – Main Actual Value ...
845-[2]	PCD read Configuration	(1612) – Motor Voltage
846-[3]	PCD read Configuration	(1613) – Frequency
847-[4]	PCD read Configuration	(1614) – Motor Current
848-[5]	PCD read Configuration	(1614) – Motor Current
849-[6]	PCD read Configuration	(1610) – Power KW
850-[7]	PCD read Configuration	(1610) – Power KW
851-[8]	PCD read Configuration	(1502) – Kwh Counter
852-[9]	PCD read Configuration	(1502) – Kwh Counter
853-[10]	PCD read Configuration	(1501) – Running Hours
854-[11]	PCD read Configuration	(1501) – Running Hours
855-[12]	PCD read Configuration	(1601) – Reference [Unit]
856-[13]	PCD read Configuration	(1601) – Reference [Unit]
857-[14]	PCD read Configuration	(1617) – Speed [RPM]
858-[15]	PCD read Configuration	(1617) – Speed [RPM]
859-[16]	PCD read Configuration	(1615) – Frequency [%]

NOTE

#Make ramp-up time (341) and ramp-down time (342) settings as follows:

Motor kW	Ramp up time	Ramp down time
11 KW to 45 KW	25sec	15 sec
55 KW and 75 KW	30 sec	20 sec
160 KW	30 sec	30 sec

Compressor controller setting in Operator menu VFD settings.

Item	Min	Max	Default	Unit
Optimum speed	on/off	on/off	off	-
P-Gain	0	50000	100	-
I-Gain	0	5000	100	-
I-Time	0	200	10	-
Max. speed	Factory setting can be viewed			RPM
Min. speed				RPM
Optimum speed				RPM
UL speed				RPM
High (5V)				RPM
Low (1V)				RPM

This information is for reference only. The settings are all made at the factory. You need not perform these settings at your site. However, P, I, and integral time settings need to be configured during installation.

Branch offices

AHMEDABAD	"ELGI HOUSE" 2, Mill Officer's Colony, Behind La-Gajjar Chambers, (Old Reserve Bank), Opp. Times of India, Ashram Road, Ahmedabad - 380 009, Tel: +961-79- 26583736, 26581274, 26587683, Fax: 91-79-6587683, E-mail: enquiry@elgi.com
BANGALORE	15,16 Richmond Road, Bangalore - 560 025, Tel: +91-80-22537208, Fax: 91-080-22293274, E-mail: enquiry@elgi.com
CHENNAI	S4-II Floor, Apollo Dubai Plaza, No-100, Mahalingapuram Main Road, Nungambakkam, Chennai - 600 034, Tel: +91-44-28172599, 28179500, Fax: 91-44-28174699, E-mail: enquiry@elgi.com
COIMBATORE	1st Floor, No.622-A, Near ELGI industrial Complex, Trichy Road, Singanallur, Coimbatore - 641 005, Tel: +91-422-2589555, Fax: 91-422-2573697, E-mail: enquiry@elgi.com
HYDERABAD	H.NO: 12-13-188, II nd Floor, Street No. 2, Taranaka, Hyderabad - 500 017, Tel: +91-40-27000435, 27000437, 27000439, 27000431, Fax: 91-40-27000438, E-mail: enquiry@elgi.com
JAIPUR	602, 6th Floor, Diamond Tower, Purani Chungi, Ajmer Road, Jaipur - 302 021, Tel: +91-141-2970120, 2970121, E-mail: enquiry@elgi.com
KOCHI	1st Floor, Asset Summit Suites, National Highway 47, Near SCMS, Kalamassery, Kochi - 683106. Tel: +91-484 -2360155, 2351904, E-mail: enquiry@elgi.com
KOLKATA	Space No. 502, Block - C, 5th Floor, Axis Mall, Action Area - 1C, New Town, Premises No. CF - 9, Kolkata - 700 156, Tel: +91-33-2324-4270, 2324-4271, Fax: 91-33-2324-4272, E-mail: enquiry@elgi.com
MUMBAI	Marol Co-op Industrial Estate Ltd. Plot No.48, Mathurdas Vassanji Road, Near Sakinaka, Andheri (East), Mumbai-400 059, Tel: +91-22-42161000, Fax: 91-22-28591601, E-mail: enquiry@elgi.com
NEW DELHI	23, Shivaji Marg, Near Karampura, Opp.DCM, New Delhi - 110 015, Tel: +91-11-25928095, 25153644, 25175018, Fax: 91-11-25459375, E-mail: enquiry@elgi.com
PUNE	White House, Ground Floor, 388/A-1/2240, Mumbai - Pune Road, Opp. Sandvik(Asia), Dapodi, Pune - 411 012, Tel: +91- 20-30635457, Fax: 91-20-4073759, E-mail: enquiry@elgi.com
RAIPUR	Om1, 1st Floor, Ashoka Millennium, Ring Road No.1, Raipur - 492 003, Chhattisgarh, Tel: +91-97520 93008, Fax: 91-771-4073759, E-mail: enquiry@elgi.com
TIRUCHENGODE	4/2, Nandhini Complex, 1st Floor, Velur Road, Tiruchengode - 637 211, Tel: +91-4288-257137, Fax: 91-4288-257693, E-mail: enquiry@elgi.com

Overseas offices

MALAYSIA	ELGI EQUIPMENTS LIMITED, No. 2A-4-6, Jalan Jubli Perak, 22/1, Section 22, 40400, Shah Alam, Selangor, Malaysia, Tel: +60 355693544 Web: www.elgi.com.my
THAILAND	ELGI EQUIPMENTS LIMITED, 223/66, 14th Floor, Building A, Country Complex, Sanphawut Road, Bang Na, Bangkok, Thailand - 10260, Tel: +6627455160, Local Use: 02-7455160, E-mail: thailand-enquiry@elgi.com, Web: www.elgi.co.th

Overseas fellow subsidiaries

AUSTRALIA	ELGI EQUIPMENTS PTY LTD., 7/66 Pritchard Road, Virginia, Queensland - 4014, Australia, Tel: +61 7 3106 0589, Fax: +61-7 3106 0537, Email: enquiry@elgi.com.au, Web: www.elgi.com.au
BRAZIL	ELGI COMPRESSORES DO BRASIL LTD, Av. Emílio Chechinatto, 4195 - Bairro São Roque da Chave, CEP:13.295-000, Itupeva - São PauloBrasil, Tel: +55-11-4496 5519, 4496 6611, E-mail: enquiry@elgi.com.br
CHINA	ELGI EQUIPMENTS (ZHEJIANG) LIMITED, West of 1st Floor, Building 2, No. 232, Yunhai Road, Jiaxing 314033 P.R. China, Tel: +86-573-82079100, Hotline: 400-826-3585 E-mail: enquiry.cn@elgi.com, Web: elgi.cn ELGI COMPRESSORS TRADING (SHANGHAI) CO.,LTD. Rm 912-913, No. 8-9, Lane 1500, South Lianhua Road, Shanghai 201108 P.R. China, Tel: +86-21-33581191, Hotline: 400-826-3585, E-mail: enquiry.cn@elgi.com, Web: elgi.cn
INDONESIA	PT ELGI EQUIPMENTS INDONESIA, Kawasan Pergudangan, Bizpark Commercial Estate, Pulogadung Jl, Raya Bekasi Km. 21, 5 Block A3 No. 12, Kel. Rawa Terate, Kec. Cakung, Pulogadung Jakarta Timur 13920, Tel: +62-21- 46822216, 46827388, E mail: indonesia-enquiry@elgi.com, Web: www.elgi.co.id
ITALY	ROTAIR Spa, Via Bernezzo-67, 12023, Caraglio (CN), Italy, Tel: +39 0171619676, Fax: +39-0171619677, E-mail: info@rotairspa.com, Web: www.rotairspa.com
MIDDLE EAST	ELGI GULF FZE, PO Box: 120695, P6-27, SAIF Zone, Sharjah, U.A.E. Tel: +971 6 557 9970, +971 50 457 6470, Fax: +971 6 557 9980, E-mail: gulfenquiry@elgi.com, Web: www.elgigulf.com
USA	ELGI COMPRESSORS USA, INC. 1500 Suite N Continental Blvd, Charlotte, NC 28273, USA. Tel: +1-704-943-7966, E-mail: usa.sales@elgi.com

FACTORY & REGISTERED OFFICE

ELGI EQUIPMENTS LIMITED

Singanallur, Coimbatore - 641 005,
India (CIN:L29120TZ1960PLC000351).
Tel: +91-422-2589555
Fax: +91-422-2573697, +91-422-2589401
E-mail: communications@elgi.com, Web: www.elgi.com

ELGI EQUIPMENTS LIMITED (FOUNDRY DIVISION)

SF No: 212/1A, 213/1, KodangipalayamVillage,
Nallatipalayam Road, Singarampalayam Post, Kinathukkadavu,
Kinathukkadavu Taluk,
Coimbatore - 642 109, India.
Tel : +91-422-2587631, 620

GLOBAL SUPPORT CENTRE

SF NO 221, 221/2 & 221/3, Kothavadi Road,
Kodangipalayam Village, Singarampalayam(PO),
Kinathukkadavu Taluk,
Coimbatore - 642 109, India.
Tel : +91-422-2587000.

ELGI EQUIPMENTS LIMITED (AIR COMPRESSOR PLANT)

SF NO 221/1 to 3 - 229/B1, B2, B3, 232/B1,B2, 234/B1, 264/B1 and 264/B2.
KothavadiRoad, Kodangipalayam Village,
Singarampalayam (PO) Kinathukkadavu
Taluk, Coimbatore - 642 109, India.
Tel : +91-422-2587000.

FELLOW SUBSIDIARIES (DOMESTIC)

ATS ELGI LIMITED,

Kurichy Private Industrial Estate, Kurichy,
Coimbatore - 641 021, India,
Tel: +91-422-2589999, 2672201-3,
Fax: +91-422-2675446,
E-mail: enquiry@ats-elgi.com,
Web: www.ats-elgi.com

ADISONS PRECISION INSTRUMENTS MFG.CO.LIMITED

Elgi Industrial Complex, Singanallur,
Coimbatore - 641 005
Tel: +91-422-2589555

ERGO DESIGN PVT LTD,

150, 2nd Main, 2nd Cross, Chelekare, Kalyan Nagar,
Bengaluru, Karnataka 560043,
Tel: +91-80-42436000

JOINT VENTURE

ELGI SAUER COMPRESSORS LIMITED,

Elgi Industrial Complex III, Singanallur,
Coimbatore - 641 005, India,
Tel: +91-422-2589555, 2589634, 2589510,
Fax: +91-422-2573697,
E-mail: info@elgisauer.com, Web: www.elgisauer.com

INDUSTRIAL AIR SOLUTIONS LLP,

1, R R Industrial Estate, Opposite Shanthi Gears Regd Office, Singanallur,
Coimbatore, Tamil Nadu 641005,
Tel: 0422 227 1862.

DIVISION

PRESSURE VESSEL DIVISION

1473 - Trichy Road, Coimbatore - 641 018,
Tel: +91-422-2589777,
Email: enquiry@elgi.com.
