

URAI-J™ DSL Frames 33J through 56J

Roots™ Universal RAI-J DSL blowers

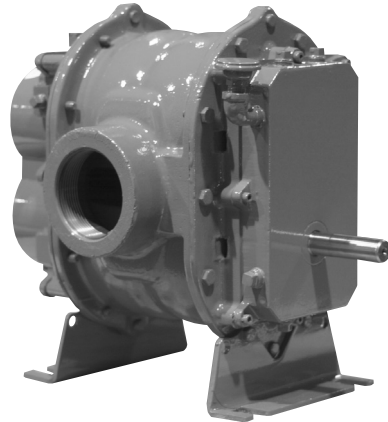

Howden



Design and construction features

- Lower air pulsation
- Longer bearing life
- Lower vibration

Howden Roots Patented Universal RAI-J™ WHISPAIR™ Dual Splash Lubricated (DSL) blowers are heavy duty rotary units in a compact, sturdy design, engineered for continuous service when operated within speed and vacuum/pressure ratings.

Basic blower description

The basic model features a cast iron casing with a computer-designed cast relief for noise and shock suppression. Carburized and ground alloy steel spur timing gears are secured to steel shafts with a taper mounting and locknut. The unit features cast iron involute impellers. Oversized anti-friction bearings are used, with a cylindrical roller bearing at the drive shaft to withstand V-belt pull. Detachable rugged steel mounting feet permit easy in-field adaptability to either vertical or horizontal installation requirements.

The Universal RAI-J™ DSL design incorporates dual splash lubrication to the gear AND drive ends. Roots' exclusive "figure-eight" gearbox design improves oil distribution to maximize bearing and gear life. Sight glasses (3/8") are provided for accurate oil level confirmation.

Lower vibration

The reduction in the magnitude of the pressure pulsation results in smoother operation.

Lower air pulsation

Patented WHISPAIR™ blowers operate with up to 40% less pressure pulsation than conventional blowers, due to the pressure equalizing effect of the WHISPAIR™ blower jet design.

In conventional blowers, as the impeller opens up to the outlet port, the higher pressure air in the discharge line rapidly expands into the lower pressure pocket formed by the impeller and the blower case. The resulting shock wave strikes the advancing surface of the impeller at nearsonic velocity. Four pressure pulses occur during each revolution, transmitting shock loads to the gear and bearings.

Longer bearing life

The pre-pressurization of the low pressure pocket through the WHISPAIR™ blower jet cavity smooths the pulsations, resulting in less shock being transmitted through the impellers to the bearings, providing longer bearing life.

Lower noise

The pressure pulses, inherent in the rotary-lobe design, are also the major source of blower noise. The rapid backflow of air into the blower from the discharge line, four times per revolution, results in high noise levels in a conventional blower. The WHISPAIR™ jet design controls the backflow of air into the blower, reducing noise by approximately 5 dBA vacuum, 3 dB pressure.

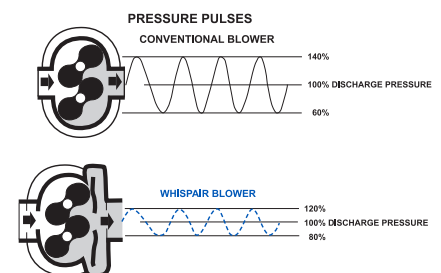
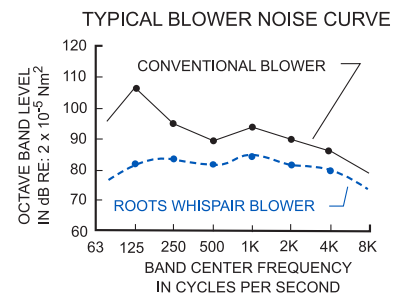
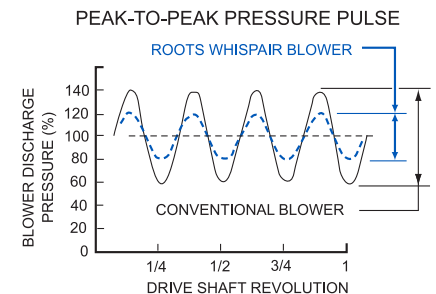

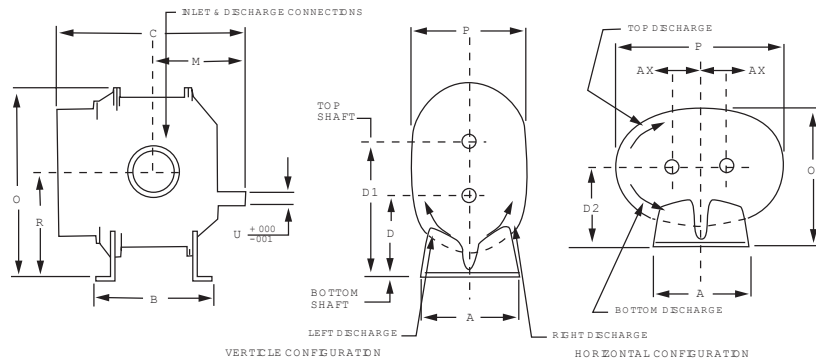

For further information contact

Howden Roots
 900 W. Mount St.
 Connersville
 Indiana
 USA
 47331
 Tel: +1 765 827 9200
 Web: www.howden.com

Outline drawing of Roots™ RAI-J DSL blower

Dimensional table

| Frame size | A | B | C | D | D1 | D2 | M | O | O1 | P | R | U | AX | Inlet disch. | Weight |
|------------|-------|-------|-------|------|-------|------|------|-------|-------|-------|------|-------|------|--------------|--------|
| 33 | 7.25 | 7.63 | 12.13 | 5.00 | 8.50 | 5.00 | 6.25 | 12.81 | 10.00 | 10.00 | 6.75 | .750 | 1.75 | 2.0 NPT | 84 |
| 36 | 7.25 | 10.00 | 14.63 | 5.00 | 8.50 | 5.00 | 7.56 | 12.81 | 10.50 | 10.50 | 6.75 | .750 | 1.75 | 2.5 NPT | 112 |
| 45 | 8.00 | 10.00 | 15.50 | 6.25 | 10.25 | 6.25 | 8.00 | 15.06 | 12.25 | 12.00 | 8.25 | .875 | 2.00 | 2.5 NPT | 119 |
| 47 | 8.00 | 11.75 | 17.63 | 6.25 | 10.25 | 6.25 | 9.25 | 15.06 | 12.25 | 12.00 | 8.25 | .875 | 2.00 | 3.0 NPT | 138 |
| 56 | 10.50 | 1.00 | 17.50 | 6.25 | 11.25 | 6.75 | 9.19 | 17.38 | 14.00 | 14.00 | 8.75 | 1.125 | 2.50 | 4.0 NPT | 190 |

Performance table

| Frame size | Speed RPM | 1 PSI | | 6 PSI | | 7 PSI | | 10 PSI | | 12 PSI | | 13 PSI | | MAX VACUUM | | |
|------------|-----------|-------|-----|-------|------|-------|------|--------|------|--------|------|--------|------|------------|-----|------|
| | | CFM | BHP | CFM | BHP | CFM | BHP | CFM | BHP | CFM | BHP | CFM | BHP | "HG | CFM | BHP |
| 33 | 1160 | 55 | 0.3 | 31 | 1.9 | 28 | 2.2 | - | - | - | - | - | - | 10 | 27 | 1.5 |
| | 2800 | 156 | 0.9 | 132 | 4.6 | 129 | 5.4 | 120 | 7.7 | 116 | 9.2 | - | - | 14 | 113 | 5.2 |
| | 3600 | 205 | 1.2 | 181 | 6.1 | 178 | 7.0 | 170 | 9.9 | 165 | 11.9 | - | - | 15 | 159 | 7.3 |
| 36 | 1160 | 95 | 0.5 | 61 | 3.1 | 57 | 3.6 | - | - | - | - | - | - | 10 | 55 | 2.5 |
| | 2800 | 262 | 1.5 | 229 | 7.7 | 224 | 8.9 | - | - | - | - | - | - | 12 | 213 | 7.5 |
| | 3600 | 344 | 2.1 | 310 | 10.1 | 306 | 11.7 | - | - | - | - | - | - | 15 | 278 | 12.1 |
| 45 | 860 | 79 | 0.5 | 42 | 2.7 | 37 | 3.2 | - | - | - | - | - | - | 8 | 46 | 1.8 |
| | 1760 | 188 | 1.0 | 151 | 5.7 | 146 | 6.6 | 133 | 9.4 | - | - | - | - | 12 | 134 | 5.5 |
| | 3600 | 410 | 2.7 | 374 | 12.2 | 369 | 14.1 | 356 | 19.8 | - | - | - | - | 16 | 332 | 15.4 |
| 47 | 860 | 105 | 0.6 | 59 | 3.6 | 53 | 4.2 | - | - | - | - | - | - | 8 | 63 | 2.4 |
| | 1760 | 249 | 1.3 | 203 | 7.5 | 196 | 8.7 | - | - | - | - | - | - | 12 | 181 | 7.3 |
| | 3600 | 542 | 3.5 | 496 | 16.1 | 490 | 18.6 | - | - | - | - | - | - | 15 | 452 | 19.1 |
| 56 | 700 | 123 | 0.7 | 78 | 4.1 | 72 | 4.7 | - | - | - | - | - | - | 10 | 70 | 3.3 |
| | 1760 | 358 | 2.0 | 312 | 10.5 | 306 | 12.2 | 290 | 17.3 | 280 | 20.6 | 276 | 22.3 | 14 | 276 | 11.8 |
| | 2850 | 598 | 4.0 | 553 | 17.7 | 547 | 20.5 | 531 | 28.7 | 521 | 34.2 | 517.0 | 37.0 | 16 | 501 | 22.4 |

Notes:

1. Pressure ratings based on inlet air at standard pressure of 14.7 psia, standard temperature of 68° F, and specific gravity of 1.0.
2. Vacuum ratings based on inlet air at standard temperature of 68°F, discharge pressure of 30" Hg and specific gravity of 1.0.